

# Stormwater Drainage Report

## Proposed Residential Development

### Project Location:

136 East Street  
South Hadley, Massachusetts 01075  
(Map 35, Parcel 6)

### Applicant & Property Owner:

136 East Street, LLC  
c/o Gerald Coderre  
383 Newton Street  
South Hadley, Massachusetts 01075



RLA Project File No. 250511

**September 30, 2025**

**Revised, December 4, 2025**

# R LEVESQUE ASSOCIATES, INC

**A LAND PLANNING SERVICES COMPANY**

40 School Street · South Hadley, MA 01085

p 413.568.0985 · f 413.568.0986 · [www.rlaland.com](http://www.rlaland.com)





## TABLE OF CONTENTS

SECTION	PAGE NO.
<b>I. INTRODUCTION.....</b>	<b>1-1</b>
<b>2. SITE DESCRIPTION .....</b>	<b>2-2</b>
2.1    Predevelopment Conditions .....	2-2
2.2    Resource Areas .....	2-2
2.2.1  Floodplain .....	2-2
2.2.2  Natural Heritage and Endangered Species Program .....	2-3
2.2.3  Aquifer Protection District.....	2-3
2.3    Soils .....	2-3
2.4    Post Development Conditions.....	2-4
<b>3. STORMWATER MANAGEMENT SYSTEM .....</b>	<b>3-5</b>
3.1    Drainage Calculations.....	3-5
3.1.1  Design Points.....	3-6
3.1.2  Pre-Development Hydrology.....	3-6
3.1.3  Post-Development Hydrology .....	3-6
3.1.4  Peak Discharge Rates.....	3-6
3.2    Hydraulic Analysis.....	3-7
3.3    MassDEP Stormwater Management Standards .....	3-7
3.4    Stormwater Best Management Practices.....	3-10
3.4.1  Proprietary Sedimentation Devices.....	3-10
3.4.2  Subsurface Infiltration Basin.....	3-10
3.5    Protection of Stormwater Best Management Practices during Construction.....	3-11
3.6    Inspection and Maintenance of Stormwater Best Management Practices.....	3-11
3.7    Illicit Discharge Compliance Statement .....	3-11
3.8    Low-Impact Development Alternatives Analysis Narrative .....	3-11
<b>4. CONCLUSION .....</b>	<b>4-12</b>

### List of Tables

Table	Page No.
Table 2.4: Hydrologic Soil Group Classification .....	2-3
Table 3.1: Design Rainfall Data – Hampshire County .....	3-5
Table 3.1.4 Pre- and Post-Development Peak Discharge Rates.....	3-6

## **List of Figures**

Figure

---

- Figure 1: Site Locus – USGS Map  
Figure 2: FEMA Flood Map  
Figure 3: NHESP Map  
Figure 4: Pre-Development Watershed Plan  
Figure 5: Post-Development Watershed Plan  
Figure 6: Inlet Area Plan

## **Appendices**

---

- APPENDIX A: CHECKLIST FOR STORMWATER REPORT  
APPENDIX B: SOILS INFORMATION  
APPENDIX C: PRE- AND POST- DEVELOPMENT HYDROLOGIC ANALYSIS  
(2, 10, & 100 YEAR STORM EVENTS)  
APPENDIX D: HYDRAULIC ANALYSIS  
APPENDIX E: MASSDEP CALCULATIONS  
APPENDIX F: CONSTRUCTION PERIOD EROSION CONTROL PLAN  
APPENDIX G: LONG-TERM OPERATION AND MAINTENANCE PLAN  
APPENDIX H: ILLICIT DISCHARGE COMPLIANCE STATEMENT  
APPENDIX I: LOW IMPACT DEVELOPMENT CONSIDERATIONS

## **I. INTRODUCTION**

---

The applicant, 136 East Street, LLC, is proposing to construct a condominium community on a parcel identified as lot 35-6 in South Hadley, Massachusetts. The proposed project will include the construction of eight (8) new condominium buildings (six duplex condominium buildings and two single unit buildings), parking areas, and other associated site improvements. Under existing conditions, stormwater runoff from the project area sheet flows west to east toward bordering vegetated wetlands located on the parcel. The proposed development will generally maintain the existing drainage patterns of the site and direct treated stormwater towards the same design points as in pre-development conditions.

The proposed project involves the following:

1. Construction of six (6) duplex condominium buildings and two (2) single unit buildings (14 total units);
2. Construction of associated site improvements including access drive, driveways, and landscaping;
3. Installation of underground utilities to the new buildings including water, sewer, and electric/telecommunications;
4. Construction of a new stormwater management system including deep-sump hooded catch basins, proprietary sedimentation devices, a subsurface infiltration basin, and a detention basin.

The purpose of this report is to present information regarding the technical aspects of the stormwater management system for the proposed project. All work is intended to be in full compliance with the Town of South Hadley Stormwater Management Permit requirements as well as the Massachusetts Department of Environmental Protection Stormwater Management Handbook.

## 2. SITE DESCRIPTION

---

### 2.1 Predevelopment Conditions

The property to be developed is located at 136 East Street and is listed as Parcel 35-6 by the Town of South Hadley Assessor’s Office. The property is zoned Residence A-1 (RA-1), as referenced from South Hadley GIS. The property is bounded to the north and south by residentially developed properties also zoned RA-1, to the west by East Street and to the east by the town line to Granby. The parcel to be developed is approximately 9.9 acres in size. Figure 1 – USGS Map illustrates the location of the project.

Reference in this report to the project “site” shall mean the area of proposed development. The subject parcel is bordered to the east by a perennial stream (Stony Brook) with bordering vegetated wetland resource areas and wooded upland area. The entirety of the proposed development is located on the western side of the resource areas and the remaining area shall remain undisturbed. The existing topography of the project site can be described as sloping down moderately from the frontage along East Street to the wetland on the western side of the project site. The existing elevations along the frontage with East street range from approximately elevation 246 at the northwesterly corner of the parcel to 241 at the southwesterly corner. From the frontage with East Street, the elevations slope down to approximately 222 at the edge of the bordering vegetated wetland. Stormwater runoff from this area generally follows the existing topography and ultimately reaches the bordering vegetated wetlands. Please refer to the existing conditions plan submitted herewith for more detailed topographical information and Figure 4 “Pre-Development Watershed Plan” for sub-catchment area boundaries.

### 2.2 Resource Areas

Portions of the proposed site improvements are located within jurisdictional buffer zone areas associated with bordering vegetated wetland (BVW) resource areas. Please refer to the Notice of Intent filing for additional buffer zone impact information.

#### 2.2.1 Floodplain

R. Levesque Associates, Inc. performed due diligence research on the property in regard to FEMA flood zone mapping. As demonstrated by the most recent FEMA Flood Insurance Rate Maps, the eastern portion of the property is located within the 100-year flood zone. The 100-year flood zone elevation for the subject property is 219’ based on said mapping. Based on NOAA LIDAR contours, the 100-year flood zone elevation is contained within the delineated BVW, see Figure 2 – FEMA FIRM Map. All proposed site improvements are located outside the floodplain areas.

## 2.2.2 Natural Heritage and Endangered Species Program

R. Levesque Associates, Inc. performed due diligence research on the property in regard to Natural Heritage and Endangered Species Program (NHESP) areas. The property is not located within an NHESP priority habitats of endangered species, see Figure 3 – NHESP Map.

## 2.2.3 Aquifer Protection District

R. Levesque Associates, Inc. performed due diligence research on the property in regard to wellhead protection overlay districts. The property is not located within a Zone II Wellhead Protection Area; see Figure 3 – NHESP & Zone II Map.

## 2.3 Soils

R. Levesque Associates, Inc. researched the soils located on site with information readily available by the United States Department of Agriculture (USDA) Natural Resources Conservation Service (NRCS). Based on a review of the USDA Soil Survey of Hampshire County, Massachusetts, Central Part, the site is comprised of the following soil types:

Soil Description	Map Unit Symbol	Hydrologic Soil Group
Walpole sandy loam	31A	B
Swansea muck	51A	D
Sudbury fine sandy loam	260A	B
Agawam fine sandy loam	275A	B
Wethersfield fine sandy loam	397B	C

A total of nineteen (19) test pits were conducted by Ryan Nelson SE# 14394 to verify the existing site soil characteristics and evaluate the ability of the site to support the proposed stormwater drainage system components. The test pits were spread out across the site in anticipated infiltration areas to establish the elevation of the estimated seasonal high groundwater and soil conditions. Ground water was encountered in all of the test pits and varied in depth from 22 inches to 68 inches below grade. The depth of the test pits varied from 70 inches to 100 inches below grade. In general, the soil evaluations found the soil conditions to contain well drained sandy material with high groundwater elevations. See Appendix B for additional soils information.

## 2.4 Post Development Conditions

The proposed site improvements include a number of stormwater management features to properly meet the requirements set forth by the Town of South Hadley Stormwater Management Permit requirements. The proposed stormwater features include:

- Deep-Sump Hooded Catch Basins
- Proprietary sedimentation devices
- Subsurface infiltration basin
- Detention basin

The applicant is proposing to construct a condominium community on the subject property. The proposed development includes the construction of eight (8) new condominium buildings (14 total units), paved access drives with associated parking areas, and a stormwater management system. The new electric, sewer, and water services will be connected via the frontage with East Street.

The proposed stormwater management systems have been designed to attenuate stormwater runoff from storm events up to and including the 100-year 24-hr event on-site. The proposed stormwater management system will collect runoff from the impervious surfaces via sheet flow and inlet structures strategically located at low points across the site. The inlet structures include yard drains and deep-sump hooded catch basins. Once collected, the stormwater is then conveyed via underground infrastructure to proprietary sedimentation devices that will provide water quality treatment prior to reaching the subsurface infiltration basin. The subsurface infiltration basin has been designed to provide peak discharge rate attenuation and the required recharge volume for the project site to mitigate for the proposed site improvements. The subsurface basin is equipped with an outlet control structure that will discharge runoff towards the bordering vegetated wetlands to mimic the existing conditions of the site.

In addition to the subsurface infiltration basin, a small detention basin is being proposed adjacent to the northern property line. Stormwater runoff from behind the northerly units is collected via a swale where it is conveyed to the detention basin. The detention basin is necessary to provide peak discharge rate attenuation. The detention basin is equipped with an outlet control structure and directs discharge downgradient to the onsite wetlands.

Overall, the proposed site improvements will maintain the general drainage patterns of the site while improving water quality and reducing/maintaining peak discharge rates. See Figure 5 – Post-Development Watershed Plan for delineation of sub-catchment areas.

### 3. STORMWATER MANAGEMENT SYSTEM

R. Levesque Associates, Inc. has prepared the following drainage system calculations for the proposed project site. These calculations were performed to document compliance with the guidelines set forth by the Town of South Hadley Stormwater Management Permit requirements and the Massachusetts Department of Environmental Protection Stormwater Management Handbook (MassDEP Handbook). A detailed hydrologic analysis of the system was completed in order to evaluate the performance of the stormwater management system components, see Appendix C – Pre- and Post-Development Hydrologic Analysis. The proposed stormwater management system will collect runoff from on-site impervious areas and utilize stormwater best management practices to provide water quality treatment, groundwater recharge, and peak discharge rate attenuation.

#### 3.1 Drainage Calculations

R. Levesque Associates, Inc. utilized the HydroCAD software program, developed by HydroCAD Software Solutions LLC, in order to create and analyze the site hydrology. The HydroCAD software is based upon the Soil Conservation Service (SCS) “Technical Release 20 – Urban Hydrology for Small Watersheds” and “Technical Release 55 – Urban Hydrology for small Watersheds” which are generally accepted industry standard methodologies. The analysis was conducted in order to establish the peak discharge rates and estimated run-off volume from the project site. This was accomplished to properly evaluate pre- and post-development conditions during various storm events. Contributing drainage areas were identified and soils, surface cover, watershed slope, and flow paths were evaluated to develop the necessary HydroCAD model input parameters.

Drainage calculations were performed for the Pre- and Post-Development conditions for the 24-hour, 2, 10, and 100-year Type III storm events. The total rainfall for each of the storm events was based upon data provided by the National Oceanic and Atmospheric Administration (NOAA) Atlas 14 point precipitation frequency estimates. The total rainfall values used in the hydrologic modeling for each event are shown in the following table:

Table 3.1: Design Rainfall Data – Hampshire County		
2-year, 24-hour storm	10-year, 24-hour storm	100-year, 24-hour storm
3.08 inches	4.97 inches	7.96 inches

### 3.1.1 Design Points

In order to compare the difference between pre- and post-development peak flows, existing and proposed watersheds were delineated. One Design Points (DP) was established with a flow path representing the longest time of concentration of run-off in each tributary watershed. For this analysis, the design point was determined as follows:

- DP-1 – Wetland: This design point represents runoff from the project area which is tributary to the onsite bordering vegetated wetland. Although not connected on the property, the two bordering vegetated wetland areas shown on the plans are tributary to the same general wetland system directly adjacent to the property.

### 3.1.2 Pre-Development Hydrology

The project area under existing conditions contains one (1) sub-catchment tributary to the design point described above. The sub-catchment was delineated based on the existing topography of the parcel and surrounding areas. The existing watershed area is shown on the attached Figure 4 entitled “Pre-Development Watershed Plan”. Peak discharge rates for the design point is depicted in Table 3.1.4.

### 3.1.3 Post-Development Hydrology

The project area under proposed conditions was broken down into four (4) sub-catchments discharging to the design point as described in existing conditions. The proposed watershed areas are shown on the attached Figure 5 entitled “Post-Development Watershed Plan”. Peak discharge rates for the design point are depicted in Table 3.1.4.

### 3.1.4 Peak Discharge Rates

The table below summarizes the Pre- and Post-Development peak discharge rates for each Design Point:

Table 3.1.4 Pre- and Post-Development Peak Discharge Rates						
	2-year storm (cfs)		10-year storm (cfs)		100-year storm (cfs)	
	Pre-	Post-	Pre-	Post-	Pre-	Post-
Design Point 1	0.5	0.5	3.7	3.3	12.2	10.2

As depicted in table 3.1.4, the post-development peak discharge rates do not increase over pre-development peak discharge rates for each of the storm events presented. This is accomplished by providing onsite attenuation through the proposed subsurface infiltration basin and surface detention basin.

### 3.2 Hydraulic Analysis

R. Levesque Associates, Inc. utilized the Hydraflow Storm Sewer Extension for AutoCAD Civil 3D 2012 software program, Version 9, developed by Autodesk, Inc., to analyze the hydraulic capacity of the proposed underground infrastructure. The analysis was conducted to verify that the proposed conveyance piping has sufficient capacity to convey up to and including the 24-hour, 100-year storm event. The data from the analysis was used to properly size the conveyance piping such that there is no or minimal surcharge of stormwater above the rim elevations within the paved areas. As part of the input parameters required for the hydraulic analysis, the tributary inlet areas were delineated based on topography, any additional connected discharges, characteristic land use coverages and flow paths, see Figure 6 – Inlet Area Plan. A minimum Time of Concentration (T<sub>c</sub>) of (6) minutes was used in the calculations. Please refer to Appendix D for the hydraulic analysis of the proposed stormwater management system.

### 3.3 MassDEP Stormwater Management Standards

R. Levesque Associates, Inc. has designed the proposed stormwater management system to be in compliance with the MassDEP Stormwater Management Standards. Chapter 1, Volume 3 of the MassDEP Handbook outlines specific calculations, and other information, that must be submitted with each report to document compliance. The following summary highlights elements of the proposed project and how they apply to each standard.

- *Standard #1 - No new stormwater conveyances (e.g., outfalls) may discharge untreated stormwater directly to or cause erosion in wetlands or waters of the Commonwealth.*

**The proposed project provides best management practices designed to the guidelines of the MassDEP Handbook. Therefore, no new untreated stormwater is discharged.**

- *Standard #2 – Stormwater management systems shall be designed so that post-development peak discharge rates do not exceed pre-development peak discharge rates. This Standard may be waived for discharges to land subject to coastal storm flowage as defined in 310 CMR 10.04.*

**The proposed stormwater management system has been designed such that the post-development peak discharge rates do not exceed the pre-development peak discharge rates**

for the 2-year, 10-year, and 100-year 24-hour storms. See Appendix C for the Hydrologic Analysis.

- *Standard #3 - Loss of annual recharge to groundwater shall be eliminated or minimized through the use of environmentally sensitive site design, low impact development techniques, stormwater BMPs, and good operation and maintenance. At a minimum, the annual recharge from the post-development site shall approximate the annual recharge from pre-development conditions based on soil type. This Standard is met when the stormwater management system is designed to infiltrate the required volume as determined in accordance with the Massachusetts Stormwater Handbook.*

The proposed subsurface infiltration basin has been designed with the capacity to infiltrate the required recharge volume for the tributary impervious areas. See Appendix E for the Required Recharge Volume Calculations.

- *Standard #4 – Stormwater management systems shall be designed to remove 80% of the average annual post-construction load of TSS. It is presumed that this standard is met when:*
  - a. Suitable practices for source control and pollution prevention are identified in a long term pollution prevention plan, and thereafter are implemented and maintained;*
  - b. Structural stormwater BMPs practices are sized to capture the required water quality volume determined in accordance with the Massachusetts Stormwater Handbook; and*
  - c. Pretreatment is provided in accordance with the Massachusetts Stormwater Handbook*

The proposed stormwater management system has been designed to provide the required total suspended solids treatment prior to discharge to the design point. Additionally, the treatment train has been designed to provide the required runoff pre-treatment prior to discharge to the subsurface infiltration basin. See Appendix E for the Water Quality and Total Suspended Solids Removal Calculations.

- *Standard #5 - For land uses with higher potential pollutant loads, source control and pollution prevention shall be implemented in accordance with the Massachusetts Stormwater Handbook to eliminate or reduce the discharge of stormwater runoff from such land uses to the maximum extent practicable. If through source control and/or pollution prevention all land uses with higher potential pollutant loads cannot be completely protected from exposure to rain, snow, snow melt, and stormwater runoff, the proponent shall use the specific structural stormwater BMPs determined by MassDEP to be suitable for such uses as provided in the Massachusetts Stormwater Handbook. Stormwater discharges from land uses with higher potential pollutant loads shall also comply with the requirements of the*

*Massachusetts Clean Waters Act, M.G.L. c. 21, §§ 26-53 and the regulations promulgated thereunder at 314 CMR 3.00, 314 CMR 4.00 and 314 CMR 5.00.*

**This standard is not applicable.**

- *Standard #6 – Stormwater discharges within the Zone II or Interim Wellhead Protection Area of a public water supply, and stormwater discharges near or to any other critical area, require the use of the specific source control and pollution prevention measures and the specific structural stormwater BMPs determined by MassDEP to be suitable for managing discharges to such areas, as provided in the Massachusetts Stormwater Handbook. A discharge is near a critical area if there is a strong likelihood of a significant impact occurring to said area, taking into account site-specific factors. Stormwater discharges to Outstanding Resource Waters and Special Resource Waters shall be removed and set back from the receiving water or wetland and receive the highest and best practical method of treatment. A "storm water discharge" as defined in 314 CMR 3.04(2)(a)1 or (b) to an Outstanding Resource Water or Special Resource Water shall comply with 314 CMR 3.00 and 314 CMR 4.00. Stormwater discharges to a Zone I or Zone A are prohibited unless essential to the operation of a public water supply.*

**This standard is not applicable.**

- *Standard #7 – A redevelopment project is required to meet the following Stormwater Management Standards only to the maximum extent practicable: Standard 2, Standard 3, and the pretreatment and structural BMPs requirements of Standards 4, 5, and 6. Existing stormwater discharges shall comply with Standard 1 only to the maximum extent practicable. A redevelopment project shall also comply with all other requirements of the Stormwater Management Standards and improve existing conditions.*

**This standard is not applicable.**

- *Standard #8 – A plan to control construction-related impacts including erosion, sedimentation and other pollutant sources during construction and land disturbance activities (construction period erosion, sedimentation, and pollution prevention) shall be developed and implemented.*

**A Construction Period Erosion Control Plan has been provided in Appendix F.**

- *Standard #9 – A long-term operation and maintenance plan shall be developed and implemented to ensure that stormwater management systems function as designed.*

**A Long-term Operation & Maintenance Plan has been provided in Appendix G.**

- *Standard #10 - All illicit discharges to the stormwater management system are prohibited.*

An illicit discharge statement will be provided prior to discharge of stormwater to post-construction BMPs. See Appendix H for a copy of the Illicit Discharge Statement.

### **3.4 Stormwater Best Management Practices**

The proposed stormwater management system was designed utilizing stormwater best management practices (BMP) as set forth by the MassDEP Handbook. The BMPs utilized as part of the stormwater management system include deep-sump hooded catch basins, proprietary sedimentation devices, a subsurface infiltration basin, and a detention basin. All the BMPs were designed to meet the requirements of the MassDEP Handbook and will provide water quality treatment, groundwater recharge, and peak rate attenuation in order to mitigate the impacts of the proposed site improvements. See Appendix E – MassDEP Calculations for the calculations required to document compliance. The following section provides a description of the best management practices (BMPs) being utilized on site.

#### **3.4.1 Deep Sump Catch Basins**

Deep-sump catch basins equipped with an oil/gas hoods are being utilized as structural pretreatment devices within the proposed stormwater management system. The catch basins will be constructed with a 4'-0" deep sumps to act as settling chambers and allow for adequate storage of collected sediments. Catch basins are typically first in the line of water quality treatment.

#### **3.4.2 Proprietary Sedimentation Devices**

Proprietary sedimentation devices are being utilized on site for the pretreatment of stormwater runoff, prior to conveyance to the subsurface basin described below. The stormwater management system is utilizing the proprietary treatment device in order to ensure that the required water quality treatment is being performed prior to discharge to the down gradient BMP.

#### **3.4.3 Subsurface Infiltration Basin**

Subsurface infiltration basins are well suited to provide groundwater recharge from watershed areas such as those associated with this project. The subsurface infiltration basin provides groundwater recharge by providing storage of runoff prior to discharge out of the system from the overflow device. The subsurface infiltration basin consists of underground stormwater chambers embedded in stone. The discharge is conveyed to the subsurface infiltration basins via up-gradient drainage infrastructure where it is detained to provide groundwater recharge. During larger storm events, overflow will discharge via the outlet control structure toward the design point.

#### **3.4.4 Dry Detention Basin**

Dry Detention basins are typically utilized for the short-term detention of stormwater runoff from watershed areas such as those associated with this project that allows for a controlled release of runoff to meet pre-development flow rates. The proposed dry detention basin has been designed to store the volume required to meet the peak rate attenuation requirements of standard 2. The tributary watershed consists of the yard area around and behind the three northernmost duplex units.

#### **3.5 Protection of Stormwater Best Management Practices during Construction**

Protection of the stormwater best management practices during construction will ensure the proper functioning of the stormwater management system and provide protection to the undisturbed areas until the site has been stabilized. Certain specific erosion and sedimentation controls and good practices to be performed by the site contractor have been documented in a Construction Period Erosion Control Plan. See Appendix F – Construction Period Erosion Control Plan.

#### **3.6 Inspection and Maintenance of Stormwater Best Management Practices**

Frequent maintenance of the stormwater best management practices is essential to ensuring that the stormwater management system will function properly long-term. The MassDEP provides guidelines for the regular inspection and maintenance of the proposed stormwater best management practices. A Long-Term Stormwater Operation and Maintenance Plan has been prepared which dictates the inspection frequency and maintenance operations for each BMP. See Appendix G – Long-Term Operation and Maintenance Plan.

#### **3.7 Illicit Discharge Compliance Statement**

RLA has prepared an Illicit Discharge Compliance Statement to document compliance with the Massachusetts Department of Environmental Protection Stormwater Management Handbook, see Appendix H.

#### **3.8 Low-Impact Development Alternatives Analysis Narrative**

RLA has prepared a Low-Impact Development Alternatives Analysis Narrative as part of the Stormwater Drainage Report, see Appendix I.

#### **4. CONCLUSION**

---

The proposed stormwater management system has been designed to mitigate the impacts of the proposed site improvements by providing control for runoff water quality and water quantity. Implementation of stormwater best management practices such as deep-sump hooded catch basins, proprietary sedimentation devices, a subsurface infiltration basin, and a surface detention basin allow for a stormwater drainage design that is in conformance with the criteria set forth in the Town of South Hadley Stormwater Management Permit requirements and the Massachusetts Department of Environmental Protection Stormwater Management Handbook.

## Figure 1: Site Locus – USGS Map



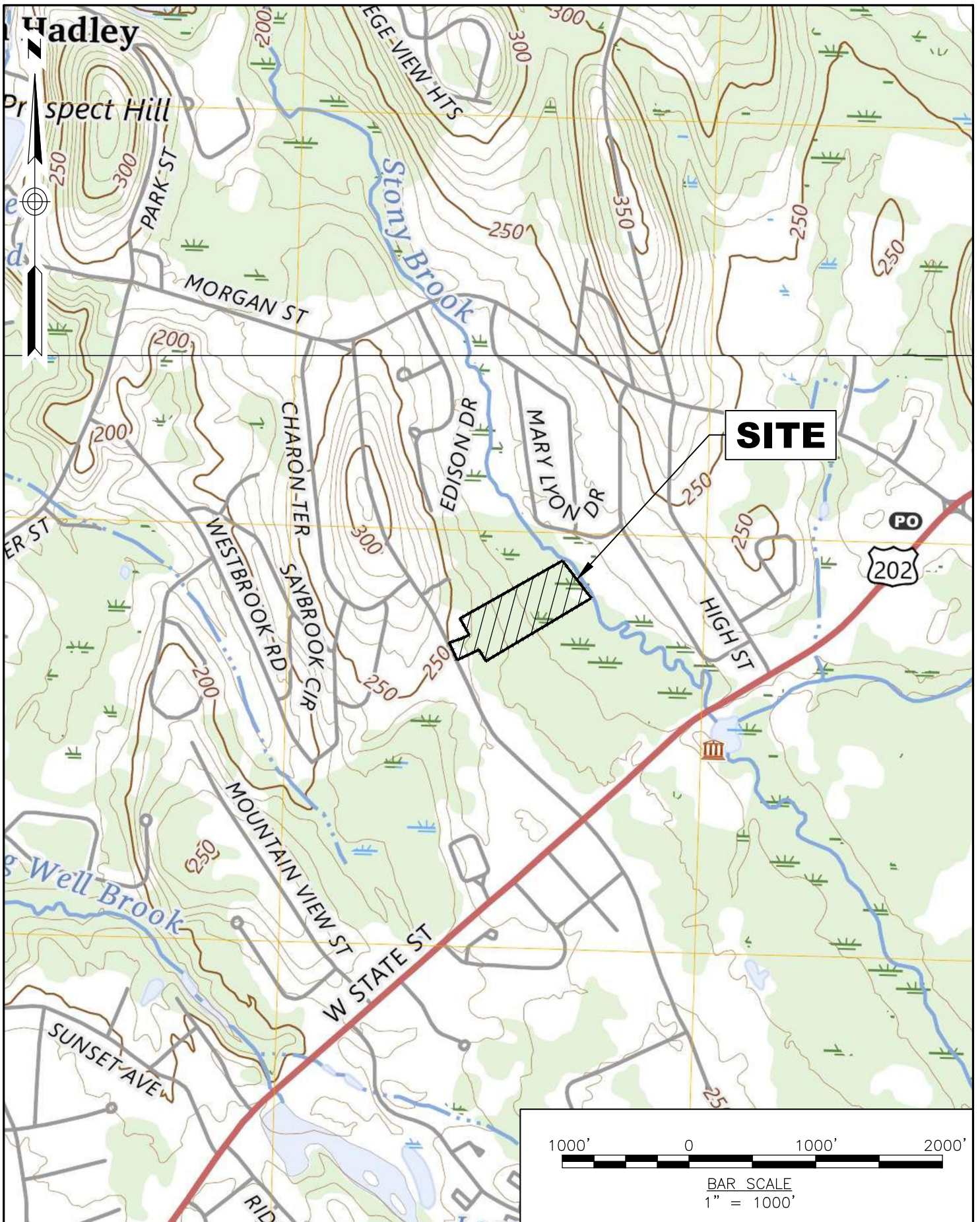

**RLA**

**R LEVESQUE ASSOCIATES, INC**  
 A Land Planning Services Company

40 School Street · P.O. Box 640 · Westfield, MA 01086  
 ph: 413.568.0985 fax: 413.568.0986 rland.com

SITE LOCUS  
 USGS MAP

136 East Street, LLC  
 383 Newton Street  
 South Hadley, MA 01075

"Deer Meadow Way"  
 136 East Street  
 South Hadley, MA 01075

JOB NO: 250511  
 DATE: 9/29/25  
 SCALE: AS NOTED

**FIG-1**



## Figure 2: FEMA Flood Map



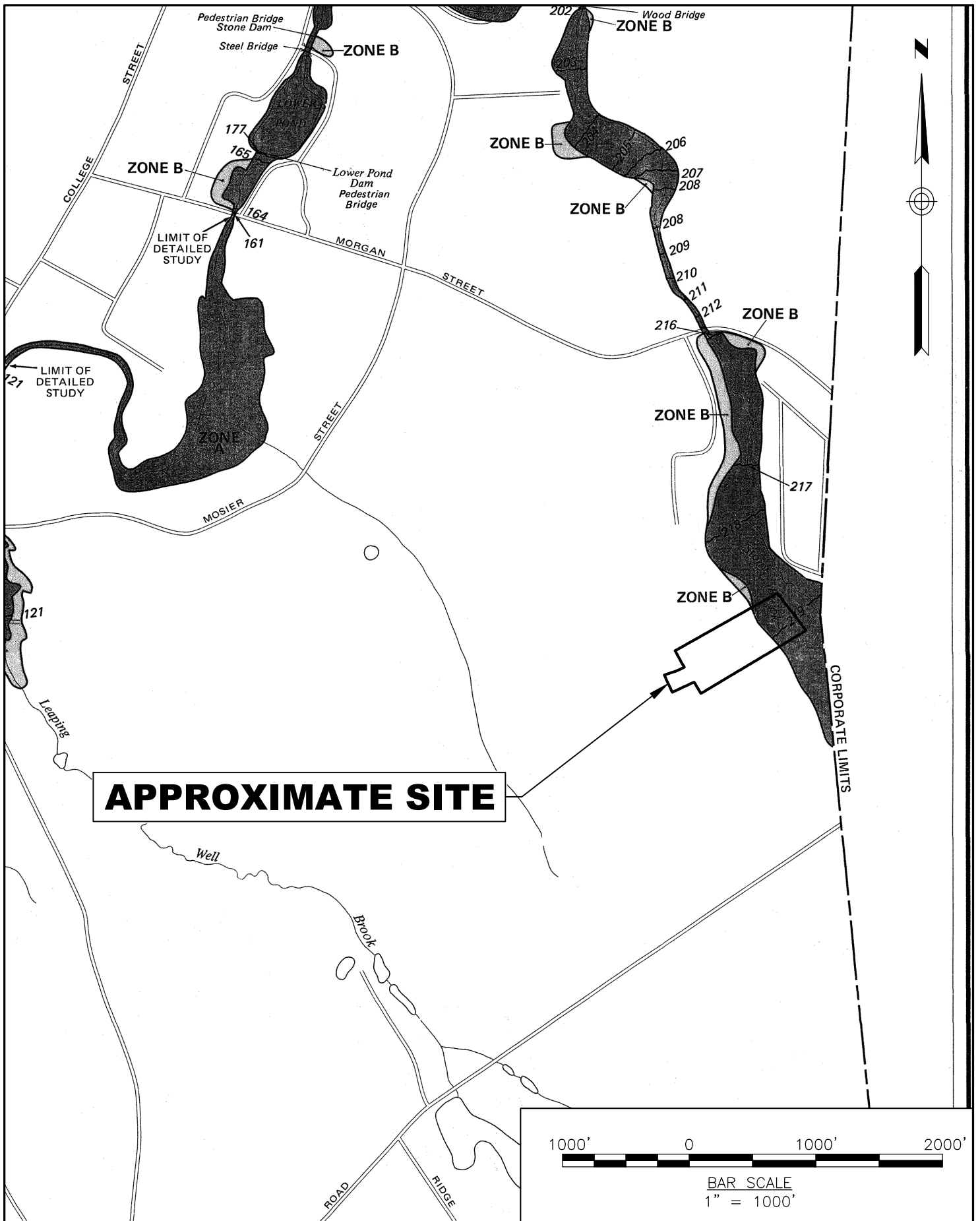

**APPROXIMATE SITE**

**RLA**

**R LEVESQUE ASSOCIATES, INC**  
 A Land Planning Services Company

40 School Street · P.O. Box 640 · Westfield, MA 01086  
 ph: 413.568.0985 fax: 413.568.0986 rland.com

FEMA  
 FLOOD MAP

136 East Street, LLC  
 383 Newton Street  
 South Hadley, MA 01075

"Deer Meadow Way"  
 136 East Street  
 South Hadley, MA 01075

JOB NO: 250511  
 DATE: 9/29/25  
 SCALE: AS NOTED

**FIG-2**



## Figure 3: NHESP Map



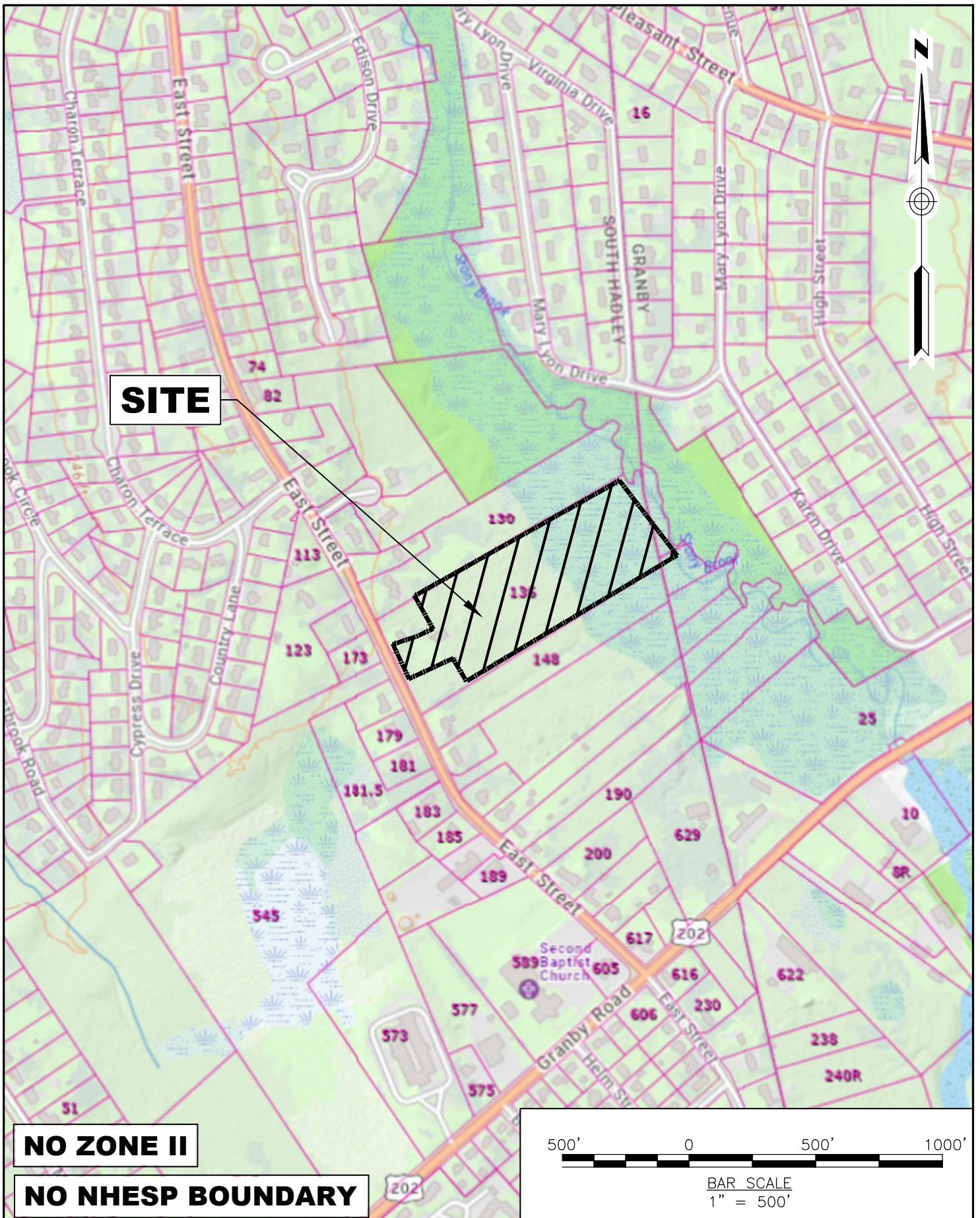

**SITE**

**NO ZONE II**

**NO NHESP BOUNDARY**



BAR SCALE  
1" = 500'

**RLA**  
**R LEVESQUE ASSOCIATES, INC**  
 A Land Planning Services Company  
 40 School Street · P.O. Box 640 · Westfield, MA 01086  
 ph: 413.568.0985 fax: 413.568.0986 rland.com

NHESP &  
 Zone II Map

136 East Street, LLC  
 383 Newton Street  
 South Hadley, MA 01075  
 "Deer Meadow Way"  
 136 East Street  
 South Hadley, MA 01075

JOB NO: 250511  
 DATE: 9/29/25  
 SCALE: AS NOTED  
**FIG-3**



## Figure 4: Pre-Development Watershed Plan



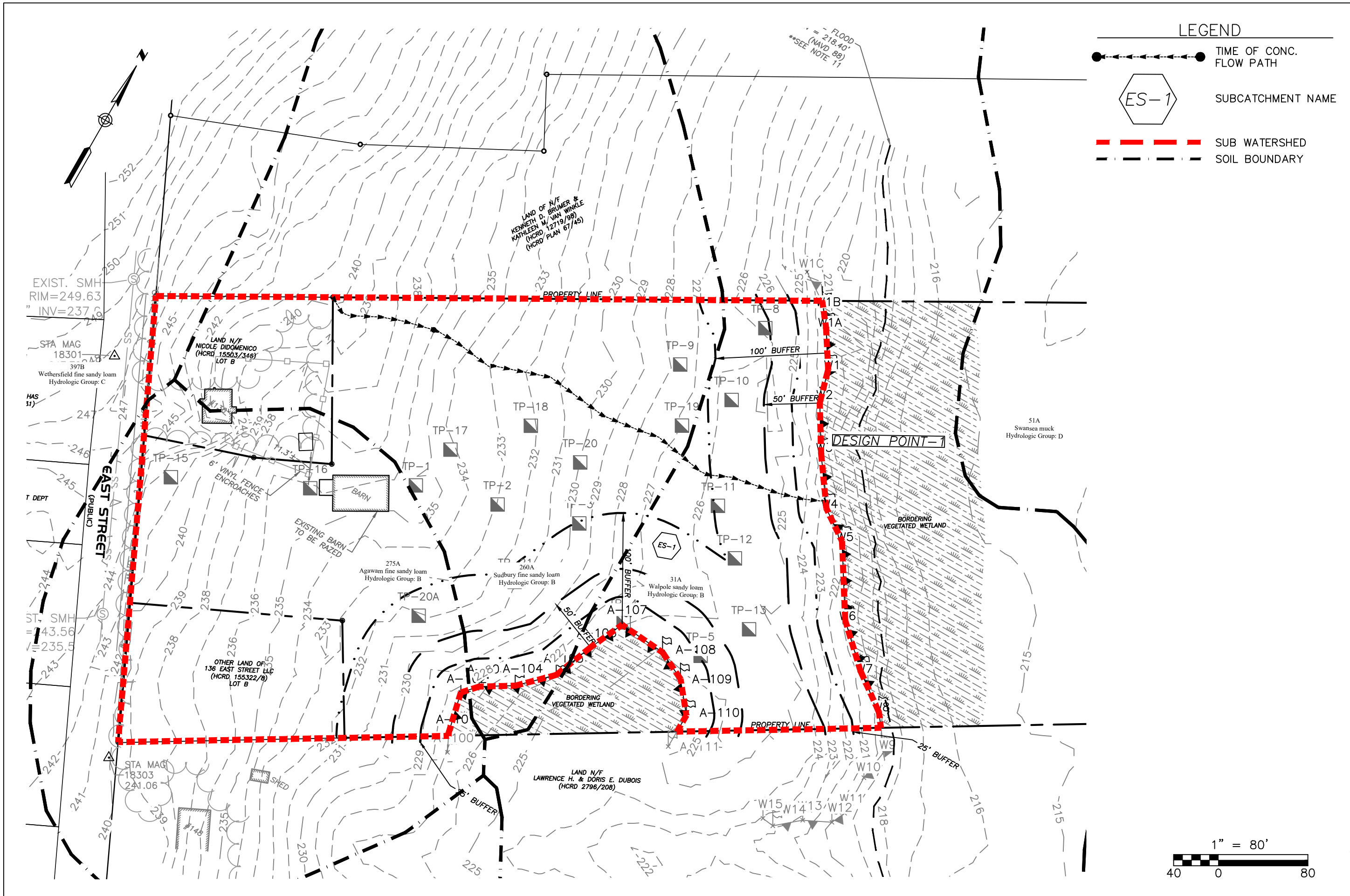

**R LEVESQUE ASSOCIATES, INC**  
 A Land Planning Services Company  
 40 School Street · P.O. Box 640 · Westfield, MA 01086  
 ph: 413.568.0985 fax: 413.568.0986 rland.com

**Pre-Development  
 Watershed Plan**

"Deer Meadow Way"  
 136 East Street  
 South Hadley, MA 01075  
 136 East St, LLC  
 c/o Gerald Coderre  
 383 Newton Street, South Hadley, MA 01075

JOB NO.: 250511  
 DATE: 12/4/25  
 SCALE: As Noted

**FIG-4**



## Figure 5: Post-Development Watershed Plan





**LEGEND**

- TIME OF CONC. FLOW PATH
- SUBCATCHMENT NAME
- SUB WATERSHED
- SOIL BOUNDARY

**R LEVESQUE ASSOCIATES, INC**  
 A Land Planning Services Company  
 40 School Street · P.O. Box 640 · Westfield, MA 01086  
 ph: 413.568.0985 fax: 413.568.0986 rland.com

**Post-Development Watershed Plan**

"Deer Meadow Way"  
 136 East Street  
 South Hadley, MA 01075  
 136 East St, LLC  
 c/o Gerald Coderre  
 383 Newton Street, South Hadley, MA 01075

JOB NO.: 250511  
 DATE: 12/4/25  
 SCALE: As Noted

**FIG-5**



## Figure 6: Inlet Area Plan



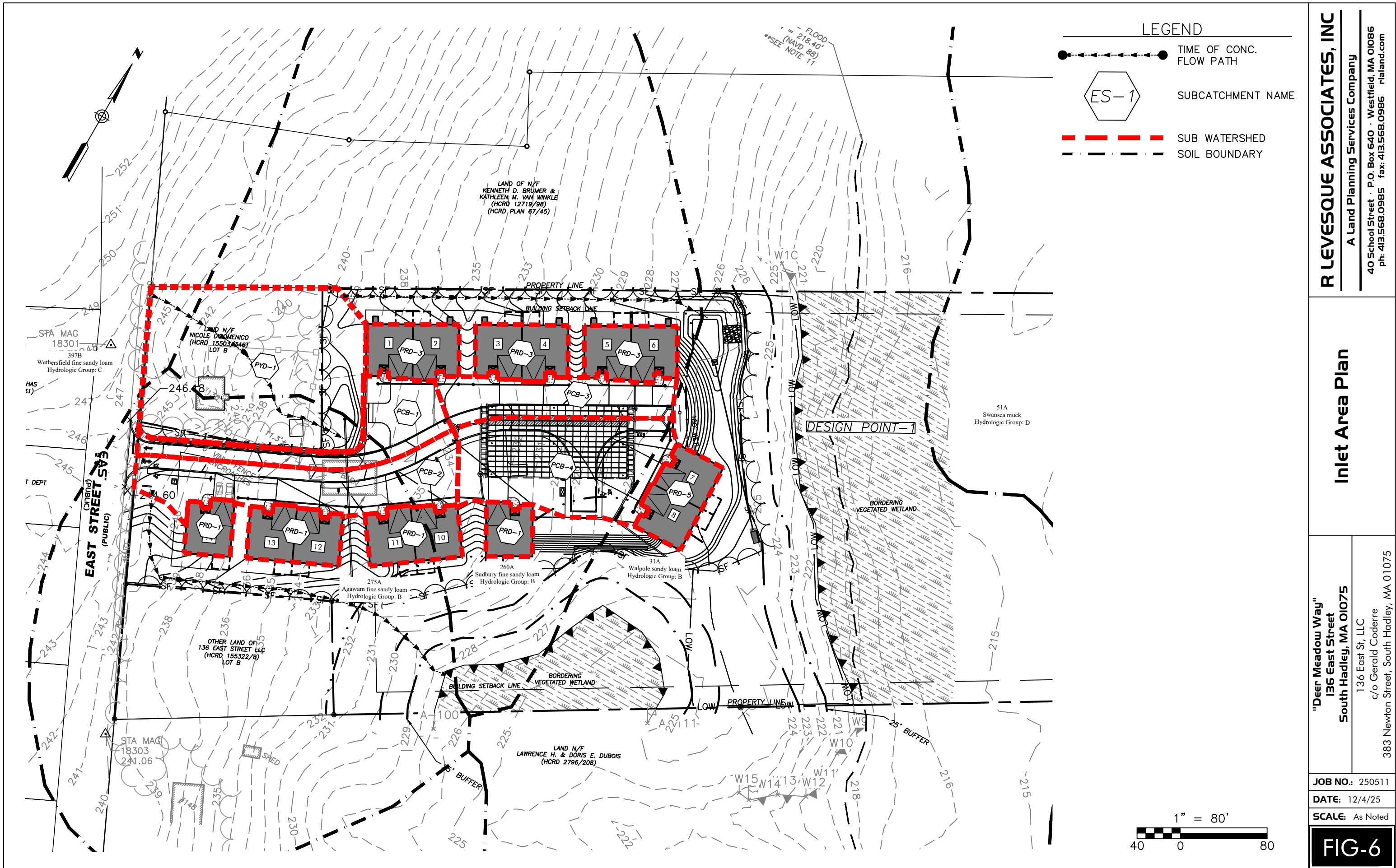

**LEGEND**

- TIME OF CONC. FLOW PATH
- SUBCATCHMENT NAME
- SUB WATERSHED
- SOIL BOUNDARY

**R LEVESQUE ASSOCIATES, INC**  
 A Land Planning Services Company  
 40 School Street · P.O. Box 640 · Westfield, MA 01086  
 ph: 413.568.0985 fax: 413.568.0986 rland.com

**Inlet Area Plan**

"Deer Meadow Way"  
 136 East Street  
 South Hadley, MA 01075  
 136 East St, LLC  
 c/o Gerald Coderre  
 383 Newton Street, South Hadley, MA 01075

JOB NO.: 250511  
 DATE: 12/4/25  
 SCALE: As Noted

**FIG-6**

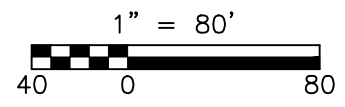



## Appendix A: Checklist for Stormwater Report





# Checklist for Stormwater Report

## A. Introduction

**Important:** When filling out forms on the computer, use only the tab key to move your cursor - do not use the return key.

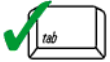

A Stormwater Report must be submitted with the Notice of Intent permit application to document compliance with the Stormwater Management Standards. The following checklist is NOT a substitute for the Stormwater Report (which should provide more substantive and detailed information) but is offered here as a tool to help the applicant organize their Stormwater Management documentation for their Report and for the reviewer to assess this information in a consistent format. As noted in the Checklist, the Stormwater Report must contain the engineering computations and supporting information set forth in Volume 3 of the [Massachusetts Stormwater Handbook](#). The Stormwater Report must be prepared and certified by a Registered Professional Engineer (RPE) licensed in the Commonwealth.

The Stormwater Report must include:

- The Stormwater Checklist completed and stamped by a Registered Professional Engineer (see page 2) that certifies that the Stormwater Report contains all required submittals.<sup>1</sup> This Checklist is to be used as the cover for the completed Stormwater Report.
- Applicant/Project Name
- Project Address
- Name of Firm and Registered Professional Engineer that prepared the Report
- Long-Term Pollution Prevention Plan required by Standards 4-6
- Construction Period Pollution Prevention and Erosion and Sedimentation Control Plan required by Standard 8<sup>2</sup>
- Operation and Maintenance Plan required by Standard 9

In addition to all plans and supporting information, the Stormwater Report must include a brief narrative describing stormwater management practices, including environmentally sensitive site design and LID techniques, along with a diagram depicting runoff through the proposed BMP treatment train. Plans are required to show existing and proposed conditions, identify all wetland resource areas, NRCS soil types, critical areas, Land Uses with Higher Potential Pollutant Loads (LUHPPL), and any areas on the site where infiltration rate is greater than 2.4 inches per hour. The Plans shall identify the drainage areas for both existing and proposed conditions at a scale that enables verification of supporting calculations.

As noted in the Checklist, the Stormwater Management Report shall document compliance with each of the Stormwater Management Standards as provided in the Massachusetts Stormwater Handbook. The soils evaluation and calculations shall be done using the methodologies set forth in Volume 3 of the Massachusetts Stormwater Handbook.

To ensure that the Stormwater Report is complete, applicants are required to fill in the Stormwater Report Checklist by checking the box to indicate that the specified information has been included in the Stormwater Report. If any of the information specified in the checklist has not been submitted, the applicant must provide an explanation. The completed Stormwater Report Checklist and Certification must be submitted with the Stormwater Report.

<sup>1</sup> The Stormwater Report may also include the Illicit Discharge Compliance Statement required by Standard 10. If not included in the Stormwater Report, the Illicit Discharge Compliance Statement must be submitted prior to the discharge of stormwater runoff to the post-construction best management practices.

<sup>2</sup> For some complex projects, it may not be possible to include the Construction Period Erosion and Sedimentation Control Plan in the Stormwater Report. In that event, the issuing authority has the discretion to issue an Order of Conditions that approves the project and includes a condition requiring the proponent to submit the Construction Period Erosion and Sedimentation Control Plan before commencing any land disturbance activity on the site.



# Checklist for Stormwater Report

## B. Stormwater Checklist and Certification

The following checklist is intended to serve as a guide for applicants as to the elements that ordinarily need to be addressed in a complete Stormwater Report. The checklist is also intended to provide conservation commissions and other reviewing authorities with a summary of the components necessary for a comprehensive Stormwater Report that addresses the ten Stormwater Standards.

*Note:* Because stormwater requirements vary from project to project, it is possible that a complete Stormwater Report may not include information on some of the subjects specified in the Checklist. If it is determined that a specific item does not apply to the project under review, please note that the item is not applicable (N.A.) and provide the reasons for that determination.

A complete checklist must include the Certification set forth below signed by the Registered Professional Engineer who prepared the Stormwater Report.

### Registered Professional Engineer's Certification

I have reviewed the Stormwater Report, including the soil evaluation, computations, Long-term Pollution Prevention Plan, the Construction Period Erosion and Sedimentation Control Plan (if included), the Long-term Post-Construction Operation and Maintenance Plan, the Illicit Discharge Compliance Statement (if included) and the plans showing the stormwater management system, and have determined that they have been prepared in accordance with the requirements of the Stormwater Management Standards as further elaborated by the Massachusetts Stormwater Handbook. I have also determined that the information presented in the Stormwater Checklist is accurate and that the information presented in the Stormwater Report accurately reflects conditions at the site as of the date of this permit application.

Registered Professional Engineer Block and Signature

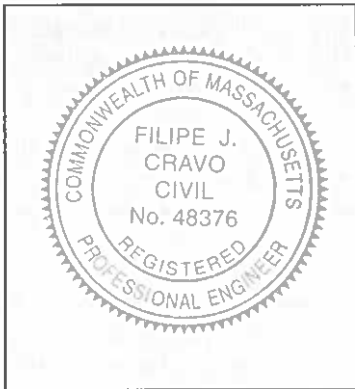

*Filipe J. Cravo* 12/4/25  
Signature and Date

### Checklist

**Project Type:** Is the application for new development, redevelopment, or a mix of new and redevelopment?

- New development
- Redevelopment
- Mix of New Development and Redevelopment



# Checklist for Stormwater Report

---

## Checklist (continued)

**LID Measures:** Stormwater Standards require LID measures to be considered. Document what environmentally sensitive design and LID Techniques were considered during the planning and design of the project:

- No disturbance to any Wetland Resource Areas
- Site Design Practices (e.g. clustered development, reduced frontage setbacks)
- Reduced Impervious Area (Redevelopment Only)
- Minimizing disturbance to existing trees and shrubs
- LID Site Design Credit Requested:
  - Credit 1
  - Credit 2
  - Credit 3
- Use of "country drainage" versus curb and gutter conveyance and pipe
- Bioretention Cells (includes Rain Gardens)
- Constructed Stormwater Wetlands (includes Gravel Wetlands designs)
- Treebox Filter
- Water Quality Swale
- Grass Channel
- Green Roof
- Other (describe): Proprietary Sedimentation Devices, Subsurface Infiltration Basin

### Standard 1: No New Untreated Discharges

- No new untreated discharges
- Outlets have been designed so there is no erosion or scour to wetlands and waters of the Commonwealth
- Supporting calculations specified in Volume 3 of the Massachusetts Stormwater Handbook included.



# Checklist for Stormwater Report

---

## Checklist (continued)

### Standard 2: Peak Rate Attenuation

- Standard 2 waiver requested because the project is located in land subject to coastal storm flowage and stormwater discharge is to a wetland subject to coastal flooding.
- Evaluation provided to determine whether off-site flooding increases during the 100-year 24-hour storm.
- Calculations provided to show that post-development peak discharge rates do not exceed pre-development rates for the 2-year and 10-year 24-hour storms. If evaluation shows that off-site flooding increases during the 100-year 24-hour storm, calculations are also provided to show that post-development peak discharge rates do not exceed pre-development rates for the 100-year 24-hour storm.

### Standard 3: Recharge

- Soil Analysis provided.
- Required Recharge Volume calculation provided.
- Required Recharge volume reduced through use of the LID site Design Credits.
- Sizing the infiltration, BMPs is based on the following method: Check the method used.
  - Static
  - Simple Dynamic
  - Dynamic Field<sup>1</sup>
- Runoff from all impervious areas at the site discharging to the infiltration BMP.
- Runoff from all impervious areas at the site is *not* discharging to the infiltration BMP and calculations are provided showing that the drainage area contributing runoff to the infiltration BMPs is sufficient to generate the required recharge volume.
- Recharge BMPs have been sized to infiltrate the Required Recharge Volume.
- Recharge BMPs have been sized to infiltrate the Required Recharge Volume *only* to the maximum extent practicable for the following reason:
  - Site is comprised solely of C and D soils and/or bedrock at the land surface
  - M.G.L. c. 21E sites pursuant to 310 CMR 40.0000
  - Solid Waste Landfill pursuant to 310 CMR 19.000
  - Project is otherwise subject to Stormwater Management Standards only to the maximum extent practicable.
- Calculations showing that the infiltration BMPs will drain in 72 hours are provided.
- Property includes a M.G.L. c. 21E site or a solid waste landfill and a mounding analysis is included.

---

<sup>1</sup> 80% TSS removal is required prior to discharge to infiltration BMP if Dynamic Field method is used.



# Checklist for Stormwater Report

---

## Checklist (continued)

### Standard 3: Recharge (continued)

- The infiltration BMP is used to attenuate peak flows during storms greater than or equal to the 10-year 24-hour storm and separation to seasonal high groundwater is less than 4 feet and a mounding analysis is provided.
- Documentation is provided showing that infiltration BMPs do not adversely impact nearby wetland resource areas.

### Standard 4: Water Quality

The Long-Term Pollution Prevention Plan typically includes the following:

- Good housekeeping practices;
  - Provisions for storing materials and waste products inside or under cover;
  - Vehicle washing controls;
  - Requirements for routine inspections and maintenance of stormwater BMPs;
  - Spill prevention and response plans;
  - Provisions for maintenance of lawns, gardens, and other landscaped areas;
  - Requirements for storage and use of fertilizers, herbicides, and pesticides;
  - Pet waste management provisions;
  - Provisions for operation and management of septic systems;
  - Provisions for solid waste management;
  - Snow disposal and plowing plans relative to Wetland Resource Areas;
  - Winter Road Salt and/or Sand Use and Storage restrictions;
  - Street sweeping schedules;
  - Provisions for prevention of illicit discharges to the stormwater management system;
  - Documentation that Stormwater BMPs are designed to provide for shutdown and containment in the event of a spill or discharges to or near critical areas or from LUHPPL;
  - Training for staff or personnel involved with implementing Long-Term Pollution Prevention Plan;
  - List of Emergency contacts for implementing Long-Term Pollution Prevention Plan.
- A Long-Term Pollution Prevention Plan is attached to Stormwater Report and is included as an attachment to the Wetlands Notice of Intent.
  - Treatment BMPs subject to the 44% TSS removal pretreatment requirement and the one inch rule for calculating the water quality volume are included, and discharge:
    - is within the Zone II or Interim Wellhead Protection Area
    - is near or to other critical areas
    - is within soils with a rapid infiltration rate (greater than 2.4 inches per hour)
    - involves runoff from land uses with higher potential pollutant loads.
  - The Required Water Quality Volume is reduced through use of the LID site Design Credits.
  - Calculations documenting that the treatment train meets the 80% TSS removal requirement and, if applicable, the 44% TSS removal pretreatment requirement, are provided.



# Checklist for Stormwater Report

---

## Checklist (continued)

### Standard 4: Water Quality (continued)

- The BMP is sized (and calculations provided) based on:
  - The ½" or 1" Water Quality Volume or
  - The equivalent flow rate associated with the Water Quality Volume and documentation is provided showing that the BMP treats the required water quality volume.
- The applicant proposes to use proprietary BMPs, and documentation supporting use of proprietary BMP and proposed TSS removal rate is provided. This documentation may be in the form of the propriety BMP checklist found in Volume 2, Chapter 4 of the Massachusetts Stormwater Handbook and submitting copies of the TARP Report, STEP Report, and/or other third party studies verifying performance of the proprietary BMPs.
- A TMDL exists that indicates a need to reduce pollutants other than TSS and documentation showing that the BMPs selected are consistent with the TMDL is provided.

### Standard 5: Land Uses With Higher Potential Pollutant Loads (LUHPPLs)

- The NPDES Multi-Sector General Permit covers the land use and the Stormwater Pollution Prevention Plan (SWPPP) has been included with the Stormwater Report.
- The NPDES Multi-Sector General Permit covers the land use and the SWPPP will be submitted **prior to** the discharge of stormwater to the post-construction stormwater BMPs.
- The NPDES Multi-Sector General Permit does **not** cover the land use.
- LUHPPLs are located at the site and industry specific source control and pollution prevention measures have been proposed to reduce or eliminate the exposure of LUHPPLs to rain, snow, snow melt and runoff, and been included in the long term Pollution Prevention Plan.
- All exposure has been eliminated.
- All exposure has **not** been eliminated and all BMPs selected are on MassDEP LUHPPL list.
- The LUHPPL has the potential to generate runoff with moderate to higher concentrations of oil and grease (e.g. all parking lots with >1000 vehicle trips per day) and the treatment train includes an oil grit separator, a filtering bioretention area, a sand filter or equivalent.

### Standard 6: Critical Areas

- The discharge is near or to a critical area and the treatment train includes only BMPs that MassDEP has approved for stormwater discharges to or near that particular class of critical area.
- Critical areas and BMPs are identified in the Stormwater Report.



# Checklist for Stormwater Report

---

## Checklist (continued)

### Standard 7: Redevelopments and Other Projects Subject to the Standards only to the maximum extent practicable

- The project is subject to the Stormwater Management Standards only to the maximum Extent Practicable as a:
  - Limited Project
  - Small Residential Projects: 5-9 single family houses or 5-9 units in a multi-family development provided there is no discharge that may potentially affect a critical area.
  - Small Residential Projects: 2-4 single family houses or 2-4 units in a multi-family development with a discharge to a critical area
  - Marina and/or boatyard provided the hull painting, service and maintenance areas are protected from exposure to rain, snow, snow melt and runoff
  - Bike Path and/or Foot Path
  - Redevelopment Project
  - Redevelopment portion of mix of new and redevelopment.
- Certain standards are not fully met (Standard No. 1, 8, 9, and 10 must always be fully met) and an explanation of why these standards are not met is contained in the Stormwater Report.
- The project involves redevelopment and a description of all measures that have been taken to improve existing conditions is provided in the Stormwater Report. The redevelopment checklist found in Volume 2 Chapter 3 of the Massachusetts Stormwater Handbook may be used to document that the proposed stormwater management system (a) complies with Standards 2, 3 and the pretreatment and structural BMP requirements of Standards 4-6 to the maximum extent practicable and (b) improves existing conditions.

### Standard 8: Construction Period Pollution Prevention and Erosion and Sedimentation Control

A Construction Period Pollution Prevention and Erosion and Sedimentation Control Plan must include the following information:

- Narrative;
  - Construction Period Operation and Maintenance Plan;
  - Names of Persons or Entity Responsible for Plan Compliance;
  - Construction Period Pollution Prevention Measures;
  - Erosion and Sedimentation Control Plan Drawings;
  - Detail drawings and specifications for erosion control BMPs, including sizing calculations;
  - Vegetation Planning;
  - Site Development Plan;
  - Construction Sequencing Plan;
  - Sequencing of Erosion and Sedimentation Controls;
  - Operation and Maintenance of Erosion and Sedimentation Controls;
  - Inspection Schedule;
  - Maintenance Schedule;
  - Inspection and Maintenance Log Form.
- A Construction Period Pollution Prevention and Erosion and Sedimentation Control Plan containing the information set forth above has been included in the Stormwater Report.



# Checklist for Stormwater Report

---

## Checklist (continued)

### Standard 8: Construction Period Pollution Prevention and Erosion and Sedimentation Control (continued)

- The project is highly complex and information is included in the Stormwater Report that explains why it is not possible to submit the Construction Period Pollution Prevention and Erosion and Sedimentation Control Plan with the application. A Construction Period Pollution Prevention and Erosion and Sedimentation Control has **not** been included in the Stormwater Report but will be submitted **before** land disturbance begins.
- The project is **not** covered by a NPDES Construction General Permit.
- The project is covered by a NPDES Construction General Permit and a copy of the SWPPP is in the Stormwater Report.
- The project is covered by a NPDES Construction General Permit but no SWPPP been submitted. The SWPPP will be submitted BEFORE land disturbance begins.

### Standard 9: Operation and Maintenance Plan

- The Post Construction Operation and Maintenance Plan is included in the Stormwater Report and includes the following information:
  - Name of the stormwater management system owners;
  - Party responsible for operation and maintenance;
  - Schedule for implementation of routine and non-routine maintenance tasks;
  - Plan showing the location of all stormwater BMPs maintenance access areas;
  - Description and delineation of public safety features;
  - Estimated operation and maintenance budget; and
  - Operation and Maintenance Log Form.
- The responsible party is **not** the owner of the parcel where the BMP is located and the Stormwater Report includes the following submissions:
  - A copy of the legal instrument (deed, homeowner's association, utility trust or other legal entity) that establishes the terms of and legal responsibility for the operation and maintenance of the project site stormwater BMPs;
  - A plan and easement deed that allows site access for the legal entity to operate and maintain BMP functions.

### Standard 10: Prohibition of Illicit Discharges

- The Long-Term Pollution Prevention Plan includes measures to prevent illicit discharges;
- An Illicit Discharge Compliance Statement is attached;
- NO Illicit Discharge Compliance Statement is attached but will be submitted **prior to** the discharge of any stormwater to post-construction BMPs.

## **Appendix B: Soils Information**

- NRCS Soils Report
- Soil Evaluation Logs





United States  
Department of  
Agriculture

**NRCS**

Natural  
Resources  
Conservation  
Service

A product of the National  
Cooperative Soil Survey,  
a joint effort of the United  
States Department of  
Agriculture and other  
Federal agencies, State  
agencies including the  
Agricultural Experiment  
Stations, and local  
participants

# Custom Soil Resource Report for Hampshire County, Massachusetts, Central Part



# Preface

---

Soil surveys contain information that affects land use planning in survey areas. They highlight soil limitations that affect various land uses and provide information about the properties of the soils in the survey areas. Soil surveys are designed for many different users, including farmers, ranchers, foresters, agronomists, urban planners, community officials, engineers, developers, builders, and home buyers. Also, conservationists, teachers, students, and specialists in recreation, waste disposal, and pollution control can use the surveys to help them understand, protect, or enhance the environment.

Various land use regulations of Federal, State, and local governments may impose special restrictions on land use or land treatment. Soil surveys identify soil properties that are used in making various land use or land treatment decisions. The information is intended to help the land users identify and reduce the effects of soil limitations on various land uses. The landowner or user is responsible for identifying and complying with existing laws and regulations.

Although soil survey information can be used for general farm, local, and wider area planning, onsite investigation is needed to supplement this information in some cases. Examples include soil quality assessments (<http://www.nrcs.usda.gov/wps/portal/nrcs/main/soils/health/>) and certain conservation and engineering applications. For more detailed information, contact your local USDA Service Center (<https://offices.sc.egov.usda.gov/locator/app?agency=nrcs>) or your NRCS State Soil Scientist ([http://www.nrcs.usda.gov/wps/portal/nrcs/detail/soils/contactus/?cid=nrcs142p2\\_053951](http://www.nrcs.usda.gov/wps/portal/nrcs/detail/soils/contactus/?cid=nrcs142p2_053951)).

Great differences in soil properties can occur within short distances. Some soils are seasonally wet or subject to flooding. Some are too unstable to be used as a foundation for buildings or roads. Clayey or wet soils are poorly suited to use as septic tank absorption fields. A high water table makes a soil poorly suited to basements or underground installations.

The National Cooperative Soil Survey is a joint effort of the United States Department of Agriculture and other Federal agencies, State agencies including the Agricultural Experiment Stations, and local agencies. The Natural Resources Conservation Service (NRCS) has leadership for the Federal part of the National Cooperative Soil Survey.

Information about soils is updated periodically. Updated information is available through the NRCS Web Soil Survey, the site for official soil survey information.

The U.S. Department of Agriculture (USDA) prohibits discrimination in all its programs and activities on the basis of race, color, national origin, age, disability, and where applicable, sex, marital status, familial status, parental status, religion, sexual orientation, genetic information, political beliefs, reprisal, or because all or a part of an individual's income is derived from any public assistance program. (Not all prohibited bases apply to all programs.) Persons with disabilities who require

alternative means for communication of program information (Braille, large print, audiotape, etc.) should contact USDA's TARGET Center at (202) 720-2600 (voice and TDD). To file a complaint of discrimination, write to USDA, Director, Office of Civil Rights, 1400 Independence Avenue, S.W., Washington, D.C. 20250-9410 or call (800) 795-3272 (voice) or (202) 720-6382 (TDD). USDA is an equal opportunity provider and employer.

# Contents

---

<b>Preface</b> .....	2
<b>How Soil Surveys Are Made</b> .....	5
<b>Soil Map</b> .....	8
Soil Map.....	9
Legend.....	10
Map Unit Legend.....	12
Map Unit Descriptions.....	12
Hampshire County, Massachusetts, Central Part.....	14
5A—Saco silt loam, frequently ponded, 0 to 2 percent slopes, frequently flooded.....	14
31A—Walpole sandy loam, 0 to 3 percent slopes.....	15
51A—Swansea muck, 0 to 1 percent slopes.....	16
260A—Sudbury fine sandy loam, 0 to 3 percent slopes.....	18
275A—Agawam fine sandy loam, 0 to 3 percent slopes.....	19
397B—Wethersfield fine sandy loam, 3 to 8 percent slopes.....	21
<b>References</b> .....	23

# How Soil Surveys Are Made

---

Soil surveys are made to provide information about the soils and miscellaneous areas in a specific area. They include a description of the soils and miscellaneous areas and their location on the landscape and tables that show soil properties and limitations affecting various uses. Soil scientists observed the steepness, length, and shape of the slopes; the general pattern of drainage; the kinds of crops and native plants; and the kinds of bedrock. They observed and described many soil profiles. A soil profile is the sequence of natural layers, or horizons, in a soil. The profile extends from the surface down into the unconsolidated material in which the soil formed or from the surface down to bedrock. The unconsolidated material is devoid of roots and other living organisms and has not been changed by other biological activity.

Currently, soils are mapped according to the boundaries of major land resource areas (MLRAs). MLRAs are geographically associated land resource units that share common characteristics related to physiography, geology, climate, water resources, soils, biological resources, and land uses (USDA, 2006). Soil survey areas typically consist of parts of one or more MLRA.

The soils and miscellaneous areas in a survey area occur in an orderly pattern that is related to the geology, landforms, relief, climate, and natural vegetation of the area. Each kind of soil and miscellaneous area is associated with a particular kind of landform or with a segment of the landform. By observing the soils and miscellaneous areas in the survey area and relating their position to specific segments of the landform, a soil scientist develops a concept, or model, of how they were formed. Thus, during mapping, this model enables the soil scientist to predict with a considerable degree of accuracy the kind of soil or miscellaneous area at a specific location on the landscape.

Commonly, individual soils on the landscape merge into one another as their characteristics gradually change. To construct an accurate soil map, however, soil scientists must determine the boundaries between the soils. They can observe only a limited number of soil profiles. Nevertheless, these observations, supplemented by an understanding of the soil-vegetation-landscape relationship, are sufficient to verify predictions of the kinds of soil in an area and to determine the boundaries.

Soil scientists recorded the characteristics of the soil profiles that they studied. They noted soil color, texture, size and shape of soil aggregates, kind and amount of rock fragments, distribution of plant roots, reaction, and other features that enable them to identify soils. After describing the soils in the survey area and determining their properties, the soil scientists assigned the soils to taxonomic classes (units). Taxonomic classes are concepts. Each taxonomic class has a set of soil characteristics with precisely defined limits. The classes are used as a basis for comparison to classify soils systematically. Soil taxonomy, the system of taxonomic classification used in the United States, is based mainly on the kind and character of soil properties and the arrangement of horizons within the profile. After the soil

## Custom Soil Resource Report

scientists classified and named the soils in the survey area, they compared the individual soils with similar soils in the same taxonomic class in other areas so that they could confirm data and assemble additional data based on experience and research.

The objective of soil mapping is not to delineate pure map unit components; the objective is to separate the landscape into landforms or landform segments that have similar use and management requirements. Each map unit is defined by a unique combination of soil components and/or miscellaneous areas in predictable proportions. Some components may be highly contrasting to the other components of the map unit. The presence of minor components in a map unit in no way diminishes the usefulness or accuracy of the data. The delineation of such landforms and landform segments on the map provides sufficient information for the development of resource plans. If intensive use of small areas is planned, onsite investigation is needed to define and locate the soils and miscellaneous areas.

Soil scientists make many field observations in the process of producing a soil map. The frequency of observation is dependent upon several factors, including scale of mapping, intensity of mapping, design of map units, complexity of the landscape, and experience of the soil scientist. Observations are made to test and refine the soil-landscape model and predictions and to verify the classification of the soils at specific locations. Once the soil-landscape model is refined, a significantly smaller number of measurements of individual soil properties are made and recorded. These measurements may include field measurements, such as those for color, depth to bedrock, and texture, and laboratory measurements, such as those for content of sand, silt, clay, salt, and other components. Properties of each soil typically vary from one point to another across the landscape.

Observations for map unit components are aggregated to develop ranges of characteristics for the components. The aggregated values are presented. Direct measurements do not exist for every property presented for every map unit component. Values for some properties are estimated from combinations of other properties.

While a soil survey is in progress, samples of some of the soils in the area generally are collected for laboratory analyses and for engineering tests. Soil scientists interpret the data from these analyses and tests as well as the field-observed characteristics and the soil properties to determine the expected behavior of the soils under different uses. Interpretations for all of the soils are field tested through observation of the soils in different uses and under different levels of management. Some interpretations are modified to fit local conditions, and some new interpretations are developed to meet local needs. Data are assembled from other sources, such as research information, production records, and field experience of specialists. For example, data on crop yields under defined levels of management are assembled from farm records and from field or plot experiments on the same kinds of soil.

Predictions about soil behavior are based not only on soil properties but also on such variables as climate and biological activity. Soil conditions are predictable over long periods of time, but they are not predictable from year to year. For example, soil scientists can predict with a fairly high degree of accuracy that a given soil will have a high water table within certain depths in most years, but they cannot predict that a high water table will always be at a specific level in the soil on a specific date.

After soil scientists located and identified the significant natural bodies of soil in the survey area, they drew the boundaries of these bodies on aerial photographs and

## Custom Soil Resource Report

identified each as a specific map unit. Aerial photographs show trees, buildings, fields, roads, and rivers, all of which help in locating boundaries accurately.

# Soil Map





































---

The soil map section includes the soil map for the defined area of interest, a list of soil map units on the map and extent of each map unit, and cartographic symbols displayed on the map. Also presented are various metadata about data used to produce the map, and a description of each soil map unit.

# Custom Soil Resource Report Soil Map



## MAP LEGEND

- Area of Interest (AOI)**
  -  Area of Interest (AOI)
- Soils**
  -  Soil Map Unit Polygons
  -  Soil Map Unit Lines
  -  Soil Map Unit Points
- Special Point Features**
  -  Blowout
  -  Borrow Pit
  -  Clay Spot
  -  Closed Depression
  -  Gravel Pit
  -  Gravelly Spot
  -  Landfill
  -  Lava Flow
  -  Marsh or swamp
  -  Mine or Quarry
  -  Miscellaneous Water
  -  Perennial Water
  -  Rock Outcrop
  -  Saline Spot
  -  Sandy Spot
  -  Severely Eroded Spot
  -  Sinkhole
  -  Slide or Slip
  -  Sodic Spot
- Water Features**
  -  Streams and Canals
- Transportation**
  -  Rails
  -  Interstate Highways
  -  US Routes
  -  Major Roads
  -  Local Roads
- Background**
  -  Aerial Photography
- Other Features**
  -  Spoil Area
  -  Stony Spot
  -  Very Stony Spot
  -  Wet Spot
  -  Other
  -  Special Line Features

## MAP INFORMATION

The soil surveys that comprise your AOI were mapped at 1:15,800.

**Warning:** Soil Map may not be valid at this scale.

Enlargement of maps beyond the scale of mapping can cause misunderstanding of the detail of mapping and accuracy of soil line placement. The maps do not show the small areas of contrasting soils that could have been shown at a more detailed scale.

Please rely on the bar scale on each map sheet for map measurements.

Source of Map: Natural Resources Conservation Service  
 Web Soil Survey URL:  
 Coordinate System: Web Mercator (EPSG:3857)

Maps from the Web Soil Survey are based on the Web Mercator projection, which preserves direction and shape but distorts distance and area. A projection that preserves area, such as the Albers equal-area conic projection, should be used if more accurate calculations of distance or area are required.

This product is generated from the USDA-NRCS certified data as of the version date(s) listed below.

Soil Survey Area: Hampshire County, Massachusetts, Central Part  
 Survey Area Data: Version 19, Aug 28, 2024

Soil map units are labeled (as space allows) for map scales 1:50,000 or larger.

Date(s) aerial images were photographed: Oct 15, 2020—Oct 31, 2020

The orthophoto or other base map on which the soil lines were compiled and digitized probably differs from the background

**MAP LEGEND**

**MAP INFORMATION**

imagery displayed on these maps. As a result, some minor shifting of map unit boundaries may be evident.

## Map Unit Legend

Map Unit Symbol	Map Unit Name	Acres in AOI	Percent of AOI
5A	Saco silt loam, frequently ponded, 0 to 2 percent slopes, frequently flooded	0.8	8.2%
31A	Walpole sandy loam, 0 to 3 percent slopes	3.1	31.5%
51A	Swansea muck, 0 to 1 percent slopes	1.9	19.4%
260A	Sudbury fine sandy loam, 0 to 3 percent slopes	2.1	21.4%
275A	Agawam fine sandy loam, 0 to 3 percent slopes	1.9	18.9%
397B	Wethersfield fine sandy loam, 3 to 8 percent slopes	0.1	0.6%
<b>Totals for Area of Interest</b>		<b>9.9</b>	<b>100.0%</b>

## Map Unit Descriptions

The map units delineated on the detailed soil maps in a soil survey represent the soils or miscellaneous areas in the survey area. The map unit descriptions, along with the maps, can be used to determine the composition and properties of a unit.

A map unit delineation on a soil map represents an area dominated by one or more major kinds of soil or miscellaneous areas. A map unit is identified and named according to the taxonomic classification of the dominant soils. Within a taxonomic class there are precisely defined limits for the properties of the soils. On the landscape, however, the soils are natural phenomena, and they have the characteristic variability of all natural phenomena. Thus, the range of some observed properties may extend beyond the limits defined for a taxonomic class. Areas of soils of a single taxonomic class rarely, if ever, can be mapped without including areas of other taxonomic classes. Consequently, every map unit is made up of the soils or miscellaneous areas for which it is named and some minor components that belong to taxonomic classes other than those of the major soils.

Most minor soils have properties similar to those of the dominant soil or soils in the map unit, and thus they do not affect use and management. These are called noncontrasting, or similar, components. They may or may not be mentioned in a particular map unit description. Other minor components, however, have properties and behavioral characteristics divergent enough to affect use or to require different management. These are called contrasting, or dissimilar, components. They generally are in small areas and could not be mapped separately because of the scale used. Some small areas of strongly contrasting soils or miscellaneous areas are identified by a special symbol on the maps. If included in the database for a given area, the contrasting minor components are identified in the map unit descriptions along with some characteristics of each. A few areas of minor components may not have been observed, and consequently they are not

## Custom Soil Resource Report

mentioned in the descriptions, especially where the pattern was so complex that it was impractical to make enough observations to identify all the soils and miscellaneous areas on the landscape.

The presence of minor components in a map unit in no way diminishes the usefulness or accuracy of the data. The objective of mapping is not to delineate pure taxonomic classes but rather to separate the landscape into landforms or landform segments that have similar use and management requirements. The delineation of such segments on the map provides sufficient information for the development of resource plans. If intensive use of small areas is planned, however, onsite investigation is needed to define and locate the soils and miscellaneous areas.

An identifying symbol precedes the map unit name in the map unit descriptions. Each description includes general facts about the unit and gives important soil properties and qualities.

Soils that have profiles that are almost alike make up a *soil series*. Except for differences in texture of the surface layer, all the soils of a series have major horizons that are similar in composition, thickness, and arrangement.

Soils of one series can differ in texture of the surface layer, slope, stoniness, salinity, degree of erosion, and other characteristics that affect their use. On the basis of such differences, a soil series is divided into *soil phases*. Most of the areas shown on the detailed soil maps are phases of soil series. The name of a soil phase commonly indicates a feature that affects use or management. For example, Alpha silt loam, 0 to 2 percent slopes, is a phase of the Alpha series.

Some map units are made up of two or more major soils or miscellaneous areas. These map units are complexes, associations, or undifferentiated groups.

A *complex* consists of two or more soils or miscellaneous areas in such an intricate pattern or in such small areas that they cannot be shown separately on the maps. The pattern and proportion of the soils or miscellaneous areas are somewhat similar in all areas. Alpha-Beta complex, 0 to 6 percent slopes, is an example.

An *association* is made up of two or more geographically associated soils or miscellaneous areas that are shown as one unit on the maps. Because of present or anticipated uses of the map units in the survey area, it was not considered practical or necessary to map the soils or miscellaneous areas separately. The pattern and relative proportion of the soils or miscellaneous areas are somewhat similar. Alpha-Beta association, 0 to 2 percent slopes, is an example.

An *undifferentiated group* is made up of two or more soils or miscellaneous areas that could be mapped individually but are mapped as one unit because similar interpretations can be made for use and management. The pattern and proportion of the soils or miscellaneous areas in a mapped area are not uniform. An area can be made up of only one of the major soils or miscellaneous areas, or it can be made up of all of them. Alpha and Beta soils, 0 to 2 percent slopes, is an example.

Some surveys include *miscellaneous areas*. Such areas have little or no soil material and support little or no vegetation. Rock outcrop is an example.

## Hampshire County, Massachusetts, Central Part

### 5A—Saco silt loam, frequently ponded, 0 to 2 percent slopes, frequently flooded

#### Map Unit Setting

*National map unit symbol:* 2zvds  
*Elevation:* 100 to 560 feet  
*Mean annual precipitation:* 40 to 50 inches  
*Mean annual air temperature:* 45 to 52 degrees F  
*Frost-free period:* 140 to 240 days  
*Farmland classification:* Not prime farmland

#### Map Unit Composition

*Saco and similar soils:* 85 percent  
*Minor components:* 15 percent  
*Estimates are based on observations, descriptions, and transects of the mapunit.*

#### Description of Saco

##### Setting

*Landform:* Alluvial flats  
*Down-slope shape:* Linear  
*Across-slope shape:* Linear  
*Parent material:* Coarse-silty alluvium

##### Typical profile

*H1 - 0 to 12 inches:* silt loam  
*H2 - 12 to 44 inches:* silt loam  
*H3 - 44 to 60 inches:* stratified fine sand to very fine sand to very fine sandy loam to silt loam

##### Properties and qualities

*Slope:* 0 to 2 percent  
*Depth to restrictive feature:* More than 80 inches  
*Drainage class:* Very poorly drained  
*Runoff class:* Very high  
*Capacity of the most limiting layer to transmit water (Ksat):* Moderately high to high (0.60 to 2.00 in/hr)  
*Depth to water table:* About 0 to 2 inches  
*Frequency of flooding:* Frequent  
*Frequency of ponding:* Frequent  
*Available water supply, 0 to 60 inches:* High (about 10.8 inches)

##### Interpretive groups

*Land capability classification (irrigated):* None specified  
*Land capability classification (nonirrigated):* 6w  
*Hydrologic Soil Group:* B/D  
*Ecological site:* F144AY016MA - Very Wet Low Floodplain  
*Hydric soil rating:* Yes

#### Minor Components

##### Limerick

*Percent of map unit:* 10 percent  
*Landform:* Alluvial flats

## Custom Soil Resource Report

*Hydric soil rating:* Yes

### **Swansea**

*Percent of map unit:* 5 percent

*Landform:* Bogs

*Hydric soil rating:* Yes

## **31A—Walpole sandy loam, 0 to 3 percent slopes**

### **Map Unit Setting**

*National map unit symbol:* 2svkl

*Elevation:* 0 to 1,350 feet

*Mean annual precipitation:* 36 to 71 inches

*Mean annual air temperature:* 39 to 55 degrees F

*Frost-free period:* 140 to 250 days

*Farmland classification:* Not prime farmland

### **Map Unit Composition**

*Walpole and similar soils:* 80 percent

*Minor components:* 20 percent

*Estimates are based on observations, descriptions, and transects of the mapunit.*

### **Description of Walpole**

#### **Setting**

*Landform:* Depressions

*Landform position (three-dimensional):* Tread

*Down-slope shape:* Concave

*Across-slope shape:* Concave

*Parent material:* Sandy glaciofluvial deposits derived from igneous, metamorphic and sedimentary rock

#### **Typical profile**

*Oe - 0 to 1 inches:* mucky peat

*A - 1 to 7 inches:* sandy loam

*Bg - 7 to 21 inches:* sandy loam

*BC - 21 to 25 inches:* gravelly sandy loam

*C - 25 to 65 inches:* very gravelly sand

#### **Properties and qualities**

*Slope:* 0 to 3 percent

*Depth to restrictive feature:* More than 80 inches

*Drainage class:* Poorly drained

*Runoff class:* Negligible

*Capacity of the most limiting layer to transmit water (Ksat):* Moderately low to high  
(0.14 to 14.17 in/hr)

*Depth to water table:* About 0 to 4 inches

*Frequency of flooding:* None

*Frequency of ponding:* None

*Maximum salinity:* Nonsaline to very slightly saline (0.0 to 2.0 mmhos/cm)

*Available water supply, 0 to 60 inches:* Moderate (about 6.4 inches)

## Custom Soil Resource Report

### Interpretive groups

*Land capability classification (irrigated):* None specified

*Land capability classification (nonirrigated):* 4w

*Hydrologic Soil Group:* B/D

*Ecological site:* F144AY028MA - Wet Outwash

*Hydric soil rating:* Yes

### Minor Components

#### Scarboro

*Percent of map unit:* 10 percent

*Landform:* Depressions

*Landform position (three-dimensional):* Tread

*Down-slope shape:* Concave

*Across-slope shape:* Concave

*Ecological site:* F144AY031MA - Very Wet Outwash

*Hydric soil rating:* Yes

#### Sudbury

*Percent of map unit:* 10 percent

*Landform:* Outwash plains

*Landform position (three-dimensional):* Dip

*Down-slope shape:* Concave

*Across-slope shape:* Linear

*Ecological site:* F144AY027MA - Moist Sandy Outwash

*Hydric soil rating:* No

## 51A—Swansea muck, 0 to 1 percent slopes

### Map Unit Setting

*National map unit symbol:* 2trl2

*Elevation:* 0 to 1,140 feet

*Mean annual precipitation:* 36 to 71 inches

*Mean annual air temperature:* 39 to 55 degrees F

*Frost-free period:* 140 to 240 days

*Farmland classification:* Not prime farmland

### Map Unit Composition

*Swansea and similar soils:* 80 percent

*Minor components:* 20 percent

*Estimates are based on observations, descriptions, and transects of the mapunit.*

### Description of Swansea

#### Setting

*Landform:* Bogs, swamps

*Landform position (three-dimensional):* Dip

*Down-slope shape:* Concave

*Across-slope shape:* Concave

## Custom Soil Resource Report

*Parent material:* Highly decomposed organic material over loose sandy and gravelly glaciofluvial deposits

### Typical profile

*Oa1 - 0 to 24 inches:* muck  
*Oa2 - 24 to 34 inches:* muck  
*Cg - 34 to 79 inches:* coarse sand

### Properties and qualities

*Slope:* 0 to 1 percent  
*Depth to restrictive feature:* More than 80 inches  
*Drainage class:* Very poorly drained  
*Runoff class:* Negligible  
*Capacity of the most limiting layer to transmit water (Ksat):* Moderately low to high (0.14 to 14.17 in/hr)  
*Depth to water table:* About 0 to 6 inches  
*Frequency of flooding:* Rare  
*Frequency of ponding:* Frequent  
*Available water supply, 0 to 60 inches:* Very high (about 16.5 inches)

### Interpretive groups

*Land capability classification (irrigated):* None specified  
*Land capability classification (nonirrigated):* 8w  
*Hydrologic Soil Group:* B/D  
*Ecological site:* F144AY043MA - Acidic Organic Wetlands  
*Hydric soil rating:* Yes

### Minor Components

#### Freetown

*Percent of map unit:* 10 percent  
*Landform:* Bogs, swamps  
*Landform position (three-dimensional):* Dip  
*Down-slope shape:* Concave  
*Across-slope shape:* Concave  
*Hydric soil rating:* Yes

#### Whitman

*Percent of map unit:* 5 percent  
*Landform:* Drainageways, depressions  
*Landform position (two-dimensional):* Toeslope  
*Landform position (three-dimensional):* Base slope  
*Down-slope shape:* Concave  
*Across-slope shape:* Concave  
*Hydric soil rating:* Yes

#### Scarboro

*Percent of map unit:* 5 percent  
*Landform:* Drainageways, depressions  
*Landform position (two-dimensional):* Toeslope  
*Landform position (three-dimensional):* Base slope, tread, dip  
*Down-slope shape:* Concave  
*Across-slope shape:* Concave  
*Hydric soil rating:* Yes

## 260A—Sudbury fine sandy loam, 0 to 3 percent slopes

### Map Unit Setting

*National map unit symbol:* 9b1z  
*Elevation:* 0 to 2,100 feet  
*Mean annual precipitation:* 40 to 50 inches  
*Mean annual air temperature:* 45 to 52 degrees F  
*Frost-free period:* 140 to 240 days  
*Farmland classification:* All areas are prime farmland

### Map Unit Composition

*Sudbury and similar soils:* 85 percent  
*Minor components:* 15 percent  
*Estimates are based on observations, descriptions, and transects of the mapunit.*

### Description of Sudbury

#### Setting

*Landform:* Outwash plains  
*Landform position (two-dimensional):* Footslope  
*Landform position (three-dimensional):* Tread  
*Down-slope shape:* Linear  
*Across-slope shape:* Concave  
*Parent material:* Friable loamy eolian deposits over loose sandy glaciofluvial deposits

#### Typical profile

*H1 - 0 to 10 inches:* fine sandy loam  
*H2 - 10 to 16 inches:* fine sandy loam  
*H3 - 16 to 28 inches:* gravelly loamy sand  
*H4 - 28 to 60 inches:* stratified gravelly sand to very gravelly loamy sand

#### Properties and qualities

*Slope:* 0 to 3 percent  
*Depth to restrictive feature:* More than 80 inches  
*Drainage class:* Moderately well drained  
*Runoff class:* Very low  
*Capacity of the most limiting layer to transmit water (Ksat):* High (2.00 to 6.00 in/hr)  
*Depth to water table:* About 18 to 36 inches  
*Frequency of flooding:* None  
*Frequency of ponding:* None  
*Available water supply, 0 to 60 inches:* Low (about 4.8 inches)

#### Interpretive groups

*Land capability classification (irrigated):* None specified  
*Land capability classification (nonirrigated):* 2w  
*Hydrologic Soil Group:* B  
*Ecological site:* F144AY027MA - Moist Sandy Outwash  
*Hydric soil rating:* No

**Minor Components**

**Merrimac**

*Percent of map unit: 5 percent*  
*Hydric soil rating: No*

**Hinckley**

*Percent of map unit: 5 percent*  
*Hydric soil rating: No*

**Walpole**

*Percent of map unit: 5 percent*  
*Landform: Terraces*  
*Hydric soil rating: Yes*

**275A—Agawam fine sandy loam, 0 to 3 percent slopes**

**Map Unit Setting**

*National map unit symbol: 2tyqw*  
*Elevation: 0 to 1,040 feet*  
*Mean annual precipitation: 36 to 71 inches*  
*Mean annual air temperature: 39 to 55 degrees F*  
*Frost-free period: 140 to 250 days*  
*Farmland classification: All areas are prime farmland*

**Map Unit Composition**

*Agawam and similar soils: 85 percent*  
*Minor components: 15 percent*  
*Estimates are based on observations, descriptions, and transects of the mapunit.*

**Description of Agawam**

**Setting**

*Landform: Moraines, kames, kame terraces, outwash plains, outwash terraces*  
*Landform position (two-dimensional): Backslope, shoulder, footslope, summit*  
*Landform position (three-dimensional): Side slope, crest, tread, riser, rise, dip*  
*Down-slope shape: Convex*  
*Across-slope shape: Convex*  
*Parent material: Coarse-loamy eolian deposits over sandy and gravelly glaciofluvial deposits derived from gneiss, granite, schist, and/or phyllite*

**Typical profile**

*Ap - 0 to 11 inches: fine sandy loam*  
*Bw1 - 11 to 16 inches: fine sandy loam*  
*Bw2 - 16 to 26 inches: fine sandy loam*  
*2C1 - 26 to 39 inches: loamy fine sand*  
*2C2 - 39 to 55 inches: loamy fine sand*  
*2C3 - 55 to 65 inches: loamy sand*

**Properties and qualities**

*Slope: 0 to 3 percent*

## Custom Soil Resource Report

*Depth to restrictive feature:* 15 to 35 inches to strongly contrasting textural stratification

*Drainage class:* Well drained

*Runoff class:* Very low

*Capacity of the most limiting layer to transmit water (Ksat):* Moderately low to high (0.14 to 14.17 in/hr)

*Depth to water table:* More than 80 inches

*Frequency of flooding:* None

*Frequency of ponding:* None

*Maximum salinity:* Nonsaline (0.0 to 1.9 mmhos/cm)

*Available water supply, 0 to 60 inches:* Low (about 3.4 inches)

### Interpretive groups

*Land capability classification (irrigated):* None specified

*Land capability classification (nonirrigated):* 2s

*Hydrologic Soil Group:* B

*Ecological site:* F145XY008MA - Dry Outwash

*Hydric soil rating:* No

### Minor Components

#### Ninigret

*Percent of map unit:* 5 percent

*Landform:* Terraces

*Down-slope shape:* Linear

*Across-slope shape:* Concave

*Hydric soil rating:* No

#### Windsor

*Percent of map unit:* 4 percent

*Landform:* Dunes, deltas, outwash terraces, outwash plains

*Landform position (three-dimensional):* Tread, riser

*Down-slope shape:* Convex, linear

*Across-slope shape:* Convex, linear

*Hydric soil rating:* No

#### Walpole

*Percent of map unit:* 3 percent

*Landform:* Deltas, depressions, outwash terraces, depressions, outwash plains

*Landform position (two-dimensional):* Toeslope

*Landform position (three-dimensional):* Tread, talf, dip

*Down-slope shape:* Concave

*Across-slope shape:* Concave

*Hydric soil rating:* Yes

#### Hinckley

*Percent of map unit:* 3 percent

*Landform:* Deltas, kames, eskers, outwash plains

*Landform position (two-dimensional):* Summit, shoulder, backslope

*Landform position (three-dimensional):* Nose slope, side slope, crest, head slope, rise

*Down-slope shape:* Convex

*Across-slope shape:* Convex, linear

*Hydric soil rating:* No

## 397B—Wethersfield fine sandy loam, 3 to 8 percent slopes

### Map Unit Setting

*National map unit symbol:* 9b26  
*Elevation:* 100 to 440 feet  
*Mean annual precipitation:* 40 to 50 inches  
*Mean annual air temperature:* 45 to 52 degrees F  
*Frost-free period:* 140 to 240 days  
*Farmland classification:* All areas are prime farmland

### Map Unit Composition

*Wethersfield and similar soils:* 85 percent  
*Minor components:* 15 percent  
*Estimates are based on observations, descriptions, and transects of the mapunit.*

### Description of Wethersfield

#### Setting

*Landform:* Hills  
*Landform position (two-dimensional):* Shoulder, summit  
*Landform position (three-dimensional):* Crest  
*Down-slope shape:* Convex  
*Across-slope shape:* Convex  
*Parent material:* Friable coarse-loamy eolian deposits over firm loamy basal till derived from sandstone and shale

#### Typical profile

*H1 - 0 to 9 inches:* fine sandy loam  
*H2 - 9 to 16 inches:* fine sandy loam  
*H3 - 16 to 23 inches:* loam  
*H4 - 23 to 26 inches:* gravelly loam  
*H5 - 26 to 60 inches:* very gravelly fine sandy loam

#### Properties and qualities

*Slope:* 3 to 8 percent  
*Depth to restrictive feature:* 20 to 31 inches to densic material  
*Drainage class:* Well drained  
*Runoff class:* High  
*Capacity of the most limiting layer to transmit water (Ksat):* Very low to moderately high (0.00 to 0.20 in/hr)  
*Depth to water table:* About 18 to 30 inches  
*Frequency of flooding:* None  
*Frequency of ponding:* None  
*Available water supply, 0 to 60 inches:* Low (about 4.0 inches)

#### Interpretive groups

*Land capability classification (irrigated):* None specified  
*Land capability classification (nonirrigated):* 2e  
*Hydrologic Soil Group:* C  
*Ecological site:* F145XY012CT - Well Drained Dense Till Uplands

## Custom Soil Resource Report

*Hydric soil rating: No*

### **Minor Components**

#### **Ridgebury**

*Percent of map unit: 5 percent*

*Landform: Depressions*

*Hydric soil rating: Yes*

#### **Woodbridge**

*Percent of map unit: 5 percent*

*Hydric soil rating: No*

#### **Paxton**

*Percent of map unit: 5 percent*

*Hydric soil rating: No*

# References

---

- American Association of State Highway and Transportation Officials (AASHTO). 2004. Standard specifications for transportation materials and methods of sampling and testing. 24th edition.
- American Society for Testing and Materials (ASTM). 2005. Standard classification of soils for engineering purposes. ASTM Standard D2487-00.
- Cowardin, L.M., V. Carter, F.C. Golet, and E.T. LaRoe. 1979. Classification of wetlands and deep-water habitats of the United States. U.S. Fish and Wildlife Service FWS/OBS-79/31.
- Federal Register. July 13, 1994. Changes in hydric soils of the United States.
- Federal Register. September 18, 2002. Hydric soils of the United States.
- Hurt, G.W., and L.M. Vasilas, editors. Version 6.0, 2006. Field indicators of hydric soils in the United States.
- National Research Council. 1995. Wetlands: Characteristics and boundaries.
- Soil Survey Division Staff. 1993. Soil survey manual. Soil Conservation Service. U.S. Department of Agriculture Handbook 18. [http://www.nrcs.usda.gov/wps/portal/nrcs/detail/national/soils/?cid=nrcs142p2\\_054262](http://www.nrcs.usda.gov/wps/portal/nrcs/detail/national/soils/?cid=nrcs142p2_054262)
- Soil Survey Staff. 1999. Soil taxonomy: A basic system of soil classification for making and interpreting soil surveys. 2nd edition. Natural Resources Conservation Service, U.S. Department of Agriculture Handbook 436. [http://www.nrcs.usda.gov/wps/portal/nrcs/detail/national/soils/?cid=nrcs142p2\\_053577](http://www.nrcs.usda.gov/wps/portal/nrcs/detail/national/soils/?cid=nrcs142p2_053577)
- Soil Survey Staff. 2010. Keys to soil taxonomy. 11th edition. U.S. Department of Agriculture, Natural Resources Conservation Service. [http://www.nrcs.usda.gov/wps/portal/nrcs/detail/national/soils/?cid=nrcs142p2\\_053580](http://www.nrcs.usda.gov/wps/portal/nrcs/detail/national/soils/?cid=nrcs142p2_053580)
- Tiner, R.W., Jr. 1985. Wetlands of Delaware. U.S. Fish and Wildlife Service and Delaware Department of Natural Resources and Environmental Control, Wetlands Section.
- United States Army Corps of Engineers, Environmental Laboratory. 1987. Corps of Engineers wetlands delineation manual. Waterways Experiment Station Technical Report Y-87-1.
- United States Department of Agriculture, Natural Resources Conservation Service. National forestry manual. [http://www.nrcs.usda.gov/wps/portal/nrcs/detail/soils/home/?cid=nrcs142p2\\_053374](http://www.nrcs.usda.gov/wps/portal/nrcs/detail/soils/home/?cid=nrcs142p2_053374)
- United States Department of Agriculture, Natural Resources Conservation Service. National range and pasture handbook. <http://www.nrcs.usda.gov/wps/portal/nrcs/detail/national/landuse/rangepasture/?cid=stelprdb1043084>

## Custom Soil Resource Report

United States Department of Agriculture, Natural Resources Conservation Service. National soil survey handbook, title 430-VI. [http://www.nrcs.usda.gov/wps/portal/nrcs/detail/soils/scientists/?cid=nrcs142p2\\_054242](http://www.nrcs.usda.gov/wps/portal/nrcs/detail/soils/scientists/?cid=nrcs142p2_054242)

United States Department of Agriculture, Natural Resources Conservation Service. 2006. Land resource regions and major land resource areas of the United States, the Caribbean, and the Pacific Basin. U.S. Department of Agriculture Handbook 296. [http://www.nrcs.usda.gov/wps/portal/nrcs/detail/national/soils/?cid=nrcs142p2\\_053624](http://www.nrcs.usda.gov/wps/portal/nrcs/detail/national/soils/?cid=nrcs142p2_053624)

United States Department of Agriculture, Soil Conservation Service. 1961. Land capability classification. U.S. Department of Agriculture Handbook 210. [http://www.nrcs.usda.gov/Internet/FSE\\_DOCUMENTS/nrcs142p2\\_052290.pdf](http://www.nrcs.usda.gov/Internet/FSE_DOCUMENTS/nrcs142p2_052290.pdf)



### Form 11 - Soil Suitability Assessment for On-Site Sewage Disposal

#### A. Facility Information

Heirs of Roland Pelissier  
 Owner Name  
 136 East Street  
 Street Address  
 South Hadley  
 City  
 MA  
 State  
 35-6  
 Map/Lot #  
 Zip Code

#### B. Site Information

- (Check one)  New Construction  Upgrade
- Soil Survey NRCS 31A Walpole Sandy loam, 0-3% slopes  
 Source Soil Map Unit Soil Series  
Depressions greater than 80" from surface  
 Landform Soil Limitations  
Sandy glaciofluvial deposits derived from igneous metamorphic and sedimentary rock  
 Soil Parent material
- Surficial Geological Report \_\_\_\_\_  
 Year Published/Source Map Unit  
 Description of Geologic Map Unit:
- Flood Rate Insurance Map Within a regulatory floodway?  Yes  No
- Within a velocity zone?  Yes  No
- Within a Mapped Wetland Area?  Yes  No If yes, MassGIS Wetland Data Layer: \_\_\_\_\_  
 Wetland Type
- Current Water Resource Conditions (USGS): \_\_\_\_\_ Range:  Above Normal  Normal  Below Normal  
 Month/Day/ Year
- Other references reviewed:  
 (Zone II, IWPA, Zone A, EEA Data Portal, etc.) \_\_\_\_\_



# Form 11 - Soil Suitability Assessment for On-Site Sewage Disposal

## C. On-Site Review (minimum of two holes required at every proposed primary and reserve disposal area)

Deep Observation Hole Number: 1+2 Hole #      6-20-2025 Date      12 pm Time      75°F Sunny Weather      \_\_\_\_\_ Latitude      \_\_\_\_\_ Longitude

1. Land Use Woodland (e.g., woodland, agricultural field, vacant lot, etc.)      Red Maple, Cherry, Vines Vegetation      N/A Surface Stones (e.g., cobbles, stones, boulders, etc.)      2-3 Slope (%)

Description of Location: \_\_\_\_\_

2. Soil Parent Material: \_\_\_\_\_ Landform \_\_\_\_\_ Position on Landscape (SU, SH, BS, FS, TS, Plain) Plain

3. Distances from:      Open Water Body >100 feet      Drainage Way >100 feet      Wetlands >100 feet  
    Property Line >100 feet      Drinking Water Well >100 feet      Other \_\_\_\_\_ feet

4. Unsuitable Materials Present:  Yes  No      If Yes:  Disturbed Soil/Fill Material       Weathered/Fractured Rock       Bedrock

5. Groundwater Observed:  Yes       No      If yes: 26" Depth to Weeping in Hole      - Depth to Standing Water in Hole

### Soil Log

Depth (in)	Soil Horizon /Layer	Soil Texture (USDA)	Soil Matrix: Color-Moist (Munsell)	Redoximorphic Features			Coarse Fragments % by Volume		Soil Structure	Soil Consistence (Moist)	Other
				Depth	Color	Percent	Gravel	Cobbles & Stones			
0-10	A	SL	10YR 3/2	-	Cnc : Dpl:	-	-	-	granular	friable	
10-25	Bw	SL	10YR 5/3	-	Cnc : Dpl:	-	-	-	massive	"	
25-	C	fine sand	10YR 6/3	46"	Cnc : 10YR 5/4 Dpl:	10%	-	-	single grain	loose	
					Cnc : Dpl:						
					Cnc : Dpl:						
					Cnc : Dpl:						

Additional Notes: \_\_\_\_\_



# Form 11 - Soil Suitability Assessment for On-Site Sewage Disposal

## C. On-Site Review (minimum of two holes required at every proposed primary and reserve disposal area)

Deep Observation Hole Number: 3      6-20-2025      11:20 AM      75°F Sunny      \_\_\_\_\_  
Hole #      Date      Time      Weather      Latitude      Longitude

1. Land Use Woodland      Red Maple, cherry, vines      N/A      \_\_\_\_\_  
(e.g., woodland, agricultural field, vacant lot, etc.)      Vegetation      Surface Stones (e.g., cobbles, stones, boulders, etc.)      Slope (%)

Description of Location: \_\_\_\_\_

2. Soil Parent Material: \_\_\_\_\_      Landform \_\_\_\_\_      Position on Landscape (SU, SH, BS, FS, TS, Plain) Plain

3. Distances from:      Open Water Body >100 feet      Drainage Way >100 feet      Wetlands >75 feet  
    Property Line >100 feet      Drinking Water Well >100 feet      Other \_\_\_\_\_ feet

4. Unsuitable Materials Present:  Yes  No      If Yes:  Disturbed Soil/Fill Material       Weathered/Fractured Rock       Bedrock

5. Groundwater Observed:  Yes       No      If yes: 66" Depth to Weeping in Hole      \_\_\_\_\_ Depth to Standing Water in Hole

### Soil Log

Depth (in)	Soil Horizon /Layer	Soil Texture (USDA)	Soil Matrix: Color-Moist (Munsell)	Redoximorphic Features			Coarse Fragments % by Volume		Soil Structure	Soil Consistence (Moist)	Other
				Depth	Color	Percent	Gravel	Cobbles & Stones			
0-10	A	SL	10YR 3/2	-	-	-	-	-	granular	friable	
10-24	Bw	SL	10YR 5/4	-	-	-	-	-	massive	"	
24-78"	C	med sand	10YR 6/3	48"	-	20%	-	-	single grain	loose	weeping

Additional Notes: \_\_\_\_\_



# Form 11 - Soil Suitability Assessment for On-Site Sewage Disposal

## C. On-Site Review (minimum of two holes required at every proposed primary and reserve disposal area)

Deep Observation Hole Number: 5,4 Hole #      6-20-2025 Date      9 AM Time      75°F Sunny Weather      \_\_\_\_\_ Latitude      \_\_\_\_\_ Longitude

1. Land Use Woodland (e.g., woodland, agricultural field, vacant lot, etc.)      Red Maple, cherry, vines Vegetation      N/A Surface Stones (e.g., cobbles, stones, boulders, etc.)      1-2 Slope (%)

Description of Location: \_\_\_\_\_

2. Soil Parent Material: \_\_\_\_\_ Landform \_\_\_\_\_ Position on Landscape (SU, SH, BS, FS, TS, Plain) Plain

3. Distances from:      Open Water Body >100 feet      Drainage Way >100 feet      Wetlands >50 feet  
    Property Line 750 feet      Drinking Water Well >100 feet      Other \_\_\_\_\_ feet

4. Unsuitable Materials Present:  Yes  No      If Yes:  Disturbed Soil/Fill Material       Weathered/Fractured Rock       Bedrock

5. Groundwater Observed:  Yes       No      If yes: 48" Depth to Weeping in Hole      < Depth to Standing Water in Hole

### Soil Log

Depth (in)	Soil Horizon /Layer	Soil Texture (USDA)	Soil Matrix: Color-Moist (Munsell)	Redoximorphic Features			Coarse Fragments % by Volume		Soil Structure	Soil Consistence (Moist)	Other
				Depth	Color	Percent	Gravel	Cobbles & Stones			
0-12	A	SL	10YR 3/2	-	Cnc : Dpl:	-	-	-	granular	friable	
12-20"	Bw	SL	10YR 5/4	-	Cnc : Dpl:	-	-	-	massive	"	
20-70"+	C	coarse sand	10YR 7/2	32"	Cnc : 10YR 5/6 Dpl: 10YR 6/1	10%	-	-	single grain	loose	weeping
					Cnc : Dpl:						
					Cnc : Dpl:						
					Cnc : Dpl:						

Additional Notes: \_\_\_\_\_



# Form 11 - Soil Suitability Assessment for On-Site Sewage Disposal

## C. On-Site Review (minimum of two holes required at every proposed primary and reserve disposal area)

Deep Observation Hole Number: 8 Hole #      6-20-2025 Date      9:30 AM Time      70°F Sunny Weather      \_\_\_\_\_ Latitude      \_\_\_\_\_ Longitude

1. Land Use Woodland (e.g., woodland, agricultural field, vacant lot, etc.)      Red maple, dogwood Vegetation      N/A Surface Stones (e.g., cobbles, stones, boulders, etc.)      1-2 Slope (%)

Description of Location: 136 East St, S. Hadley

2. Soil Parent Material: \_\_\_\_\_ Landform \_\_\_\_\_ Position on Landscape (SU, SH, BS, FS, TS, Plain) Plain

3. Distances from:      Open Water Body >100 feet      Drainage Way >100 feet      Wetlands >50 feet

   Property Line >20 feet      Drinking Water Well >100 feet      Other \_\_\_\_\_ feet

4. Unsuitable Materials Present:  Yes  No      If Yes:  Disturbed Soil/Fill Material       Weathered/Fractured Rock       Bedrock

5. Groundwater Observed:  Yes       No      If yes: 39" Depth to Weeping in Hole      \_\_\_\_\_ Depth to Standing Water in Hole

### Soil Log

Depth (in)	Soil Horizon /Layer	Soil Texture (USDA)	Soil Matrix: Color-Moist (Munsell)	Redoximorphic Features			Coarse Fragments % by Volume		Soil Structure	Soil Consistence (Moist)	Other
				Depth	Color	Percent	Gravel	Cobbles & Stones			
0-12	A	SL	10YR 3/2	-	Cnc : Dpl:	-	-	-	granular	friable	
12-24	Bw	SL	10YR 5/4	-	Cnc : Dpl:	-	-	-	massive	"	
24-71"	C	Coarse Sand	10YR 7/2	26"	Cnc : 10YR 5/6 Dpl: 10YR 6/1	25%	-	-	Single grain	loose	Weeping
					Cnc : Dpl:						
					Cnc : Dpl:						
					Cnc : Dpl:						

Additional Notes:



# Form 11 - Soil Suitability Assessment for On-Site Sewage Disposal

## C. On-Site Review (minimum of two holes required at every proposed primary and reserve disposal area)

Deep Observation Hole Number: 9, 10 Hole#      6-20-2025 Date      9:50 AM Time      70°F Cloudy Weather      \_\_\_\_\_ Latitude      \_\_\_\_\_ Longitude

1. Land Use Woodland (e.g., woodland, agricultural field, vacant lot, etc.)      \_\_\_\_\_ Vegetation      none Surface Stones (e.g., cobbles, stones, boulders, etc.)      \_\_\_\_\_ Slope (%) 1-2

Description of Location: \_\_\_\_\_

2. Soil Parent Material: \_\_\_\_\_ Landform \_\_\_\_\_ Position on Landscape (SU, SH, BS, FS, TS, Plain) Plain

3. Distances from:      Open Water Body >100 feet      Drainage Way >100 feet      Wetlands >100 feet  
    Property Line >20 feet      Drinking Water Well \_\_\_\_\_ feet      Other \_\_\_\_\_ feet

4. Unsuitable Materials Present:  Yes  No      If Yes:  Disturbed Soil/Fill Material       Weathered/Fractured Rock       Bedrock

5. Groundwater Observed:  Yes       No      If yes: 72" Depth to Weeping in Hole      \_\_\_\_\_ Depth to Standing Water in Hole

### Soil Log

Depth (in)	Soil Horizon /Layer	Soil Texture (USDA)	Soil Matrix: Color-Moist (Munsell)	Redoximorphic Features			Coarse Fragments % by Volume		Soil Structure	Soil Consistence (Moist)	Other
				Depth	Color	Percent	Gravel	Cobbles & Stones			
0-12	A	SL	10YR 3/2	-	Cnc : Dpl:	-	-	-	Granular	Friable	
12-24	Bw	SL	10YR 5/4	-	Cnc : Dpl:	-	-	-	Massive	"	
24-91+	C	Coarse Sand	10YR 7/2	24"	Cnc : 10YR 5/6 Dpl: 10YR 6/1	25%	-	-	Single grain	loose	weeping
					Cnc : Dpl:						
					Cnc : Dpl:						
					Cnc : Dpl:						

Additional Notes: \_\_\_\_\_



# Form 11 - Soil Suitability Assessment for On-Site Sewage Disposal

## C. On-Site Review (minimum of two holes required at every proposed primary and reserve disposal area)

Deep Observation Hole Number: 11/12 Hole #      6-20-2025 Date      10:45 AM Time      75°F Sunny Weather      \_\_\_\_\_ Latitude      \_\_\_\_\_ Longitude

1. Land Use Woodland (e.g., woodland, agricultural field, vacant lot, etc.)      bitters Vegetation      N/A Surface Stones (e.g., cobbles, stones, boulders, etc.)      1-2 Slope (%)

Description of Location: \_\_\_\_\_

2. Soil Parent Material: \_\_\_\_\_ Landform \_\_\_\_\_ Position on Landscape (SU, SH, BS, FS, TS, Plain) plain

3. Distances from:      Open Water Body >100 feet      Drainage Way >100 feet      Wetlands >75 feet  
    Property Line >100 feet      Drinking Water Well >100 feet      Other \_\_\_\_\_ feet

4. Unsuitable Materials Present:  Yes  No      If Yes:  Disturbed Soil/Fill Material       Weathered/Fractured Rock       Bedrock

5. Groundwater Observed:  Yes       No      If yes: 48" Depth to Weeping in Hole      - Depth to Standing Water in Hole

### Soil Log

Depth (in)	Soil Horizon /Layer	Soil Texture (USDA)	Soil Matrix: Color-Moist (Munsell)	Redoximorphic Features			Coarse Fragments % by Volume		Soil Structure	Soil Consistence (Moist)	Other
				Depth	Color	Percent	Gravel	Cobbles & Stones			
0-12	A	SL	10YR 3/2	-	Cnc : Dpl:	-	-	-	granular	friable	
12-24	Bw	SL	10YR 5/4	-	Cnc : Dpl:	-	-	-	massive	"	
24-70"+	C	coarse sand	10YR 7/2	<del>34"</del>	Cnc : 10YR 5/6 Dpl: 10YR 6/1	10%	-	-	single grain	loose	weeping
					Cnc : Dpl:						
					Cnc : Dpl:						
					Cnc : Dpl:						

Additional Notes: \_\_\_\_\_



# Form 11 - Soil Suitability Assessment for On-Site Sewage Disposal

## C. On-Site Review (minimum of two holes required at every proposed primary and reserve disposal area)

Deep Observation Hole Number: 13 Hole #      6-20-2025 Date      11 AM Time      75F Sunny Weather      \_\_\_\_\_ Latitude      \_\_\_\_\_ Longitude

1. Land Use Woodland (e.g., woodland, agricultural field, vacant lot, etc.)      red maple, dogwood, vines Vegetation      N/A Surface Stones (e.g., cobbles, stones, boulders, etc.)      1-2 Slope (%)

Description of Location: \_\_\_\_\_

2. Soil Parent Material: \_\_\_\_\_ Landform \_\_\_\_\_ Position on Landscape (SU, SH, BS, FS, TS, Plain) Plain

3. Distances from:      Open Water Body >100 feet      Drainage Way >100 feet      Wetlands >75 feet

Property Line >50 feet      Drinking Water Well >100 feet      Other \_\_\_\_\_ feet

4. Unsuitable Materials Present:  Yes  No      If Yes:  Disturbed Soil/Fill Material       Weathered/Fractured Rock       Bedrock

5. Groundwater Observed:  Yes       No      If yes: 50" Depth to Weeping in Hole      \_\_\_\_\_ Depth to Standing Water in Hole

### Soil Log

Depth (in)	Soil Horizon /Layer	Soil Texture (USDA)	Soil Matrix: Color-Moist (Munsell)	Redoximorphic Features			Coarse Fragments % by Volume		Soil Structure	Soil Consistence (Moist)	Other
				Depth	Color	Percent	Gravel	Cobbles & Stones			
0-12	A	SL	10YR 3/2	-	Cnc : - Dpl: -	-	-	-	granular	friable	
12-24	Bw	SL	10YR 5/4	-	Cnc : - Dpl: -	-	-	-	massive	"	
24-70"+	C	Coarse Sand	10YR 7/2	34"	Cnc : 10YR 5/6 Dpl: 10YR 6/1	25%	-	-	single grain	loose	Weeping
					Cnc : Dpl:						
					Cnc : Dpl:						
					Cnc : Dpl:						

Additional Notes: \_\_\_\_\_



# Form 11 - Soil Suitability Assessment for On-Site Sewage Disposal

## F. Certification

I certify that I am currently approved by the Department of Environmental Protection pursuant to 310 CMR 15.017 to conduct soil evaluations and that the above analysis has been performed by me consistent with the required training, expertise and experience described in 310 CMR 15.017. I further certify that the results of my soil evaluation, as indicated in the attached Soil Evaluation Form, are accurate and in accordance with 310 CMR 15.100 through 15.107.

Ryan Nelson  
Signature of Soil Evaluator

6-20-2025  
Date

Ryan Nelson #14394  
Typed or Printed Name of Soil Evaluator / License #

6/30/2025  
Expiration Date of License

N/A  
Name of Approving Authority Witness

\_\_\_\_\_  
Approving Authority

**Note:** In accordance with 310 CMR 15.018(2) this form must be submitted to the approving authority within 60 days of the date of field testing, and to the designer and the property owner with Percolation Test Form 12.

**Field Diagrams:** Use this area for field diagrams:

See attached sketch



Commonwealth of Massachusetts  
City/Town of S. Hadley

Coderre - East Street

### Form 11 - Soil Suitability Assessment for On-Site Sewage Disposal

#### C. On-Site Review (minimum of two holes required at every proposed primary and reserve disposal area)

Deep Observation Hole Number: 15 Hole #      7-18-2025 Date      8 AM Time      75°F Sunny Weather      \_\_\_\_\_ Latitude      \_\_\_\_\_ Longitude

1. Land Use Woodland (e.g., woodland, agricultural field, vacant lot, etc.)      Locust, cherry Vegetation      N/A Surface Stones (e.g., cobbles, stones, boulders, etc.)      3-5 Slope (%)

Description of Location: \_\_\_\_\_

2. Soil Parent Material: \_\_\_\_\_ Landform \_\_\_\_\_ Position on Landscape (SU, SH, BS, FS, TS, Plain) BS

3. Distances from:      Open Water Body >100 feet      Drainage Way >50 feet      Wetlands >100 feet  
    Property Line >15 feet      Drinking Water Well >100 feet      Other \_\_\_\_\_ feet

4. Unsuitable Materials Present:  Yes  No      If Yes:  Disturbed Soil/Fill Material       Weathered/Fractured Rock       Bedrock

5. Groundwater Observed:  Yes       No      If yes: 30" Depth to Weeping in Hole      \_\_\_\_\_ Depth to Standing Water in Hole

#### Soil Log

Depth (in)	Soil Horizon /Layer	Soil Texture (USDA)	Soil Matrix: Color-Moist (Munsell)	Redoximorphic Features			Coarse Fragments % by Volume		Soil Structure	Soil Consistence (Moist)	Other
				Depth	Color	Percent	Gravel	Cobbles & Stones			
0-12	A	SL	10YR 3/2	-	Cnc : -	-	-	-	granular	very Friable	
				-	Dpl: -						
12-30	Bw	SL	10YR 5/4	22"	Cnc : 10YR 5/6	10%	-	-	massive	"	
					Dpl: 10YR 5/1						
30-80"	C <sub>D</sub>	SL	7.5YR 5/3	-	Cnc : -	-	15	2	"	firm	loose in hand
					Dpl: -						
					Cnc : -						
					Dpl: -						
					Cnc : -						
					Dpl: -						
					Cnc : -						
					Dpl: -						

Additional Notes: \_\_\_\_\_



# Form 11 - Soil Suitability Assessment for On-Site Sewage Disposal

## C. On-Site Review (minimum of two holes required at every proposed primary and reserve disposal area)

Deep Observation Hole Number: 16 Hole #      7-18-2025 Date      8:20 AM Time      75°F Sunny Weather      \_\_\_\_\_ Latitude      \_\_\_\_\_ Longitude

1. Land Use Overgrown farm (e.g., woodland, agricultural field, vacant lot, etc.)      Locust, catalpa Vegetation      N/A Surface Stones (e.g., cobbles, stones, boulders, etc.)      2-3 Slope (%)

Description of Location: \_\_\_\_\_

2. Soil Parent Material: \_\_\_\_\_ Landform \_\_\_\_\_ Position on Landscape (SU, SH, BS, FS, TS, Plain) BS

3. Distances from:      Open Water Body >100 feet      Drainage Way >100 feet      Wetlands >100 feet  
    Property Line >75 feet      Drinking Water Well >100 feet      Other \_\_\_\_\_ feet

4. Unsuitable Materials Present:  Yes  No      If Yes:  Disturbed Soil/Fill Material       Weathered/Fractured Rock       Bedrock

5. Groundwater Observed:  Yes       No      If yes: 80" Depth to Weeping in Hole      \_\_\_\_\_ Depth to Standing Water in Hole

### Soil Log

Depth (in)	Soil Horizon /Layer	Soil Texture (USDA)	Soil Matrix: Color-Moist (Munsell)	Redoximorphic Features			Coarse Fragments % by Volume		Soil Structure	Soil Consistence (Moist)	Other
				Depth	Color	Percent	Gravel	Cobbles & Stones			
0-16	A	LS	10YR 3/2	-	Cnc : -	-	-	-	granular	Very friable	
				-	Dpl: -						
16-44	Bw	LS	10YR 5/4	-	Cnc : -	-	-	-	massive	"	
				-	Dpl: -						
44-100+	C	fine sand	10YR 6/4	66"	Cnc : 10YR 5/4	10%	-	-	Single grain	loose	
					Dpl: 10YR 6/2						
					Cnc :						
					Dpl:						
					Cnc :						
					Dpl:						
					Cnc :						
					Dpl:						

Additional Notes: \_\_\_\_\_



# Form 11 - Soil Suitability Assessment for On-Site Sewage Disposal

## C. On-Site Review (minimum of two holes required at every proposed primary and reserve disposal area)

Deep Observation Hole Number: 17      7-18-2025      8:40 AM      75°F Sunny      \_\_\_\_\_      \_\_\_\_\_  
Hole #      Date      Time      Weather      Latitude      Longitude

1. Land Use Overgrown farm      Herbaceous      N/A      \_\_\_\_\_  
(e.g., woodland, agricultural field, vacant lot, etc.)      Vegetation      Surface Stones (e.g., cobbles, stones, boulders, etc.)      Slope (%)

Description of Location: \_\_\_\_\_

2. Soil Parent Material: \_\_\_\_\_      BS  
Landform      Position on Landscape (SU, SH, BS, FS, TS, Plain)

3. Distances from:      Open Water Body >100 feet      Drainage Way >100 feet      Wetlands >100 feet  
    Property Line >100 feet      Drinking Water Well >100 feet      Other \_\_\_\_\_ feet

4. Unsuitable Materials Present:  Yes  No      If Yes:  Disturbed Soil/Fill Material       Weathered/Fractured Rock       Bedrock

5. Groundwater Observed:  Yes       No      If yes: 88" Depth to Weeping in Hole      100" Depth to Standing Water in Hole

### Soil Log

Depth (in)	Soil Horizon /Layer	Soil Texture (USDA)	Soil Matrix: Color-Moist (Munsell)	Redoximorphic Features			Coarse Fragments % by Volume		Soil Structure	Soil Consistence (Moist)	Other
				Depth	Color	Percent	Gravel	Cobbles & Stones			
0-8	A	LS	10YR 3/2	-	Cnc : - Dpl: -	-	-	-	granular	Very Friable	
8-24	Bw	LS	10YR 5/4	-	Cnc : - Dpl: -	-	-	-	massive	"	
68-100"+	C	fine Sand	10YR 6/4	68"	Cnc : 10YR 5/4 Dpl: -	20%	-	-	Single grain	loose	
					Cnc : Dpl:						
					Cnc : Dpl:						
					Cnc : Dpl:						

Additional Notes: \_\_\_\_\_



# Form 11 - Soil Suitability Assessment for On-Site Sewage Disposal

## C. On-Site Review (minimum of two holes required at every proposed primary and reserve disposal area)

Deep Observation Hole Number: 18 Hole #      7-18-2025 Date      8:30 AM Time      75°F Sunny Weather      \_\_\_\_\_ Latitude      \_\_\_\_\_ Longitude

1. Land Use Overgrown farm (e.g., woodland, agricultural field, vacant lot, etc.)      Herbaceous Vegetation      N/A Surface Stones (e.g., cobbles, stones, boulders, etc.)      2-3 Slope (%)

Description of Location: \_\_\_\_\_

2. Soil Parent Material: \_\_\_\_\_ Landform \_\_\_\_\_ Position on Landscape (SU, SH, BS, FS, TS, Plain) BS

3. Distances from:      Open Water Body >100 feet      Drainage Way >100 feet      Wetlands >100 feet  
    Property Line >100 feet      Drinking Water Well >100 feet      Other \_\_\_\_\_ feet

4. Unsuitable Materials Present:  Yes  No      If Yes:  Disturbed Soil/Fill Material       Weathered/Fractured Rock       Bedrock

5. Groundwater Observed:  Yes       No      If yes: 86" Depth to Weeping in Hole      \_\_\_\_\_ Depth to Standing Water in Hole

### Soil Log

Depth (in)	Soil Horizon /Layer	Soil Texture (USDA)	Soil Matrix: Color-Moist (Munsell)	Redoximorphic Features			Coarse Fragments % by Volume		Soil Structure	Soil Consistence (Moist)	Other
				Depth	Color	Percent	Gravel	Cobbles & Stones			
0-12	A	LS	10YR 3/2	-	Cnc : - Dpl: -	-	-	-	granular	very friable	
12-34	Bw	LS	10YR 5/4	-	Cnc : - Dpl: -	-	-	-	massive	II	
34-100"	C	fine sand	10YR 6/4	50"	Cnc : 10YR 5/6 Dpl: 10YR 6/1	15%	-	-	single grain	loose	
					Cnc : Dpl:						
					Cnc : Dpl:						
					Cnc : Dpl:						

Additional Notes: \_\_\_\_\_



# Form 11 - Soil Suitability Assessment for On-Site Sewage Disposal

## C. On-Site Review (minimum of two holes required at every proposed primary and reserve disposal area)

Deep Observation Hole Number: 19 Hole #      7-18-2025 Date      9:30 AM Time      75°F Sunny Weather      \_\_\_\_\_ Latitude      \_\_\_\_\_ Longitude

1. Land Use Overgrown farm (e.g., woodland, agricultural field, vacant lot, etc.)      Herbaceous Vegetation      N/A Surface Stones (e.g., cobbles, stones, boulders, etc.)      2-3 Slope (%)

Description of Location: \_\_\_\_\_

2. Soil Parent Material: \_\_\_\_\_ Landform \_\_\_\_\_ Position on Landscape (SU, SH, BS, FS, TS, Plain) BS

3. Distances from:      Open Water Body >100 feet      Drainage Way >100 feet      Wetlands >50 feet  
    Property Line >100 feet      Drinking Water Well >100 feet      Other \_\_\_\_\_ feet

4. Unsuitable Materials Present:  Yes  No      If Yes:  Disturbed Soil/Fill Material       Weathered/Fractured Rock       Bedrock

5. Groundwater Observed:  Yes       No      If yes: 64" Depth to Weeping in Hole      \_\_\_\_\_ Depth to Standing Water in Hole

### Soil Log

Depth (in)	Soil Horizon /Layer	Soil Texture (USDA)	Soil Matrix: Color-Moist (Munsell)	Redoximorphic Features			Coarse Fragments % by Volume		Soil Structure	Soil Consistence (Moist)	Other
				Depth	Color	Percent	Gravel	Cobbles & Stones			
0-12	A	LS	10YR 3/2	-	Cnc : - Dpl: -	-	-	-	granular	very friable	
12-40	Bw	LS	10YR 5/4	-	Cnc : - Dpl: -	-	-	-	massive	"	
40-80"	C	fine sand	10YR 7/2	40"	Cnc : 10YR 5/8 Dpl: 10YR 6/1	20%	-	-	single grain	loose	hole collapsing
					Cnc : Dpl:						
					Cnc : Dpl:						
					Cnc : Dpl:						

Additional Notes: heavy weeping



# Form 11 - Soil Suitability Assessment for On-Site Sewage Disposal

## C. On-Site Review (minimum of two holes required at every proposed primary and reserve disposal area)

Deep Observation Hole Number: 20 Hole #      7-18-2025 Date      9 AM Time      75°F Sunny Weather      Latitude \_\_\_\_\_ Longitude \_\_\_\_\_

1. Land Use overgrown farm (e.g., woodland, agricultural field, vacant lot, etc.)      Herbaceous Vegetation      N/A Surface Stones (e.g., cobbles, stones, boulders, etc.)      2-3 Slope (%)

Description of Location: \_\_\_\_\_

2. Soil Parent Material: \_\_\_\_\_ Landform \_\_\_\_\_ Position on Landscape (SU, SH, BS, FS, TS, Plain) BS

3. Distances from:      Open Water Body >100 feet      Drainage Way >100 feet      Wetlands >100 feet  
    Property Line >100 feet      Drinking Water Well >100 feet      Other \_\_\_\_\_ feet

4. Unsuitable Materials Present:  Yes  No      If Yes:  Disturbed Soil/Fill Material       Weathered/Fractured Rock       Bedrock

5. Groundwater Observed:  Yes       No      If yes: 76" Depth to Weeping in Hole      \_\_\_\_\_ Depth to Standing Water in Hole

### Soil Log

Depth (in)	Soil Horizon /Layer	Soil Texture (USDA)	Soil Matrix: Color-Moist (Munsell)	Redoximorphic Features			Coarse Fragments % by Volume		Soil Structure	Soil Consistence (Moist)	Other
				Depth	Color	Percent	Gravel	Cobbles & Stones			
0-10	A	LS	10YR 3/2	-	Cnc : - Dpl: -	-	-	-	granular	Very friable	
10-22	Bw	LS	10YR 5/4	-	Cnc : - Dpl: -	-	-	-	massive	"	
22-100"	C	Fine Sand	10YR 6/4	<del>52"</del> Corrected 32"	Cnc : 10YR 5/6 Dpl: 10YR 6/2	15%	-	-	Single grain	loose	
					Cnc : Dpl:						
					Cnc : Dpl:						
					Cnc : Dpl:						

Additional Notes: \_\_\_\_\_



# Form 11 - Soil Suitability Assessment for On-Site Sewage Disposal

## C. On-Site Review (minimum of two holes required at every proposed primary and reserve disposal area)

Deep Observation Hole Number: 21 + 20A 7-18-2025 9:15 AM 75°F Sunny \_\_\_\_\_  
Hole # Date Time Weather Latitude Longitude

1. Land Use Woodland Cherry, maple N/A \_\_\_\_\_  
(e.g., woodland, agricultural field, vacant lot, etc.) Vegetation Surface Stones (e.g., cobbles, stones, boulders, etc.) Slope (%)

Description of Location: \_\_\_\_\_

2. Soil Parent Material: \_\_\_\_\_ BS \_\_\_\_\_  
Landform Position on Landscape (SU, SH, BS, FS, TS, Plain)

3. Distances from: Open Water Body >100 feet Drainage Way >100 feet Wetlands >50 feet  
Property Line >50 feet Drinking Water Well >100 feet Other \_\_\_\_\_ feet

4. Unsuitable Materials Present:  Yes  No If Yes:  Disturbed Soil/Fill Material  Weathered/Fractured Rock  Bedrock

5. Groundwater Observed:  Yes  No If yes: 9" Depth to Weeping in Hole \_\_\_\_\_ Depth to Standing Water in Hole

### Soil Log

Depth (in)	Soil Horizon /Layer	Soil Texture (USDA)	Soil Matrix: Color-Moist (Munsell)	Redoximorphic Features			Coarse Fragments % by Volume		Soil Structure	Soil Consistence (Moist)	Other
				Depth	Color	Percent	Gravel	Cobbles & Stones			
0-10	A	LS	10YR 3/2	-	Cnc : Dpl:	-	-	-	granular	Very friable	
10-32	Bw	LS	10YR 5/4	-	Cnc : Dpl:	-	-	-	massive	"	
32-100"	C	fine Sand	10YR 6/3	<del>5</del> 48"	Cnc : 10YR 5/4 Dpl: 10YR 6/1	10%	-	-	Single grain	loose	
					Cnc : Dpl:						
					Cnc : Dpl:						
					Cnc : Dpl:						

Additional Notes: \_\_\_\_\_

## **Appendix C: Pre- and Post- Development Hydrologic Analysis (2, 10, 100 Year Storm Events)**





NOAA Atlas 14, Volume 10, Version 3  
 Location name: South Hadley, Massachusetts,  
 USA\*

Latitude: 42.2435°, Longitude: -72.5582°

Elevation: 236 ft\*\*

\* source: ESRI Maps  
 \*\* source: USGS



POINT PRECIPITATION FREQUENCY ESTIMATES

Sanja Perica, Sandra Pavlovic, Michael St. Laurent, Carl Trypaluk, Dale Unruh, Orlan Wilhite

NOAA, National Weather Service, Silver Spring, Maryland

[PF tabular](#) | [PF graphical](#) | [Maps & aerials](#)

PF tabular

PDS-based point precipitation frequency estimates with 90% confidence intervals (in inches) <sup>1</sup>										
Duration	Average recurrence interval (years)									
	1	2	5	10	25	50	100	200	500	1000
5-min	0.331 (0.255-0.421)	0.395 (0.305-0.504)	0.500 (0.385-0.640)	0.588 (0.449-0.758)	0.709 (0.525-0.958)	0.800 (0.581-1.11)	0.895 (0.631-1.29)	0.998 (0.671-1.48)	1.14 (0.741-1.76)	1.26 (0.797-1.99)
10-min	0.468 (0.361-0.597)	0.560 (0.431-0.714)	0.710 (0.546-0.909)	0.834 (0.637-1.08)	1.00 (0.744-1.36)	1.13 (0.822-1.57)	1.27 (0.894-1.82)	1.41 (0.950-2.10)	1.62 (1.05-2.50)	1.78 (1.13-2.82)
15-min	0.551 (0.425-0.702)	0.659 (0.508-0.840)	0.835 (0.641-1.07)	0.980 (0.749-1.26)	1.18 (0.875-1.60)	1.33 (0.968-1.84)	1.49 (1.05-2.14)	1.66 (1.12-2.47)	1.90 (1.23-2.94)	2.10 (1.33-3.31)
30-min	0.748 (0.577-0.953)	0.895 (0.690-1.14)	1.14 (0.871-1.45)	1.33 (1.02-1.72)	1.61 (1.19-2.17)	1.81 (1.32-2.51)	2.03 (1.43-2.92)	2.26 (1.52-3.36)	2.59 (1.68-4.00)	2.86 (1.81-4.51)
60-min	0.945 (0.729-1.20)	1.13 (0.872-1.44)	1.44 (1.10-1.84)	1.69 (1.29-2.17)	2.03 (1.50-2.75)	2.30 (1.67-3.18)	2.57 (1.81-3.69)	2.86 (1.92-4.25)	3.28 (2.12-5.06)	3.62 (2.29-5.71)
2-hr	1.20 (0.939-1.52)	1.44 (1.12-1.81)	1.81 (1.41-2.30)	2.12 (1.64-2.71)	2.56 (1.91-3.43)	2.88 (2.11-3.96)	3.22 (2.30-4.63)	3.62 (2.44-5.33)	4.20 (2.73-6.44)	4.68 (2.97-7.34)
3-hr	1.38 (1.08-1.73)	1.64 (1.29-2.07)	2.08 (1.63-2.63)	2.44 (1.90-3.10)	2.95 (2.22-3.95)	3.32 (2.45-4.56)	3.72 (2.68-5.36)	4.20 (2.84-6.16)	4.92 (3.20-7.52)	5.54 (3.52-8.66)
6-hr	1.71 (1.35-2.12)	2.07 (1.64-2.57)	2.66 (2.10-3.32)	3.15 (2.47-3.96)	3.83 (2.92-5.10)	4.32 (3.23-5.93)	4.87 (3.56-7.02)	5.56 (3.77-8.11)	6.63 (4.33-10.1)	7.58 (4.83-11.8)
12-hr	2.08 (1.66-2.56)	2.57 (2.06-3.17)	3.39 (2.70-4.19)	4.06 (3.22-5.06)	4.99 (3.84-6.62)	5.66 (4.28-7.74)	6.42 (4.74-9.25)	7.39 (5.04-10.7)	8.96 (5.87-13.5)	10.3 (6.62-16.0)
24-hr	2.45 (1.98-2.99)	3.08 (2.49-3.76)	4.11 (3.31-5.04)	4.97 (3.98-6.13)	6.15 (4.78-8.10)	7.00 (5.35-9.52)	7.96 (5.94-11.4)	9.22 (6.32-13.3)	11.3 (7.41-16.9)	13.1 (8.41-20.1)
2-day	2.82 (2.31-3.40)	3.55 (2.90-4.29)	4.74 (3.86-5.76)	5.74 (4.64-7.01)	7.10 (5.58-9.29)	8.10 (6.24-10.9)	9.21 (6.93-13.2)	10.7 (7.36-15.3)	13.1 (8.65-19.5)	15.3 (9.83-23.3)
3-day	3.08 (2.54-3.70)	3.87 (3.19-4.65)	5.16 (4.23-6.23)	6.24 (5.08-7.58)	7.71 (6.09-10.0)	8.78 (6.80-11.8)	9.99 (7.55-14.2)	11.6 (8.01-16.5)	14.2 (9.40-21.1)	16.6 (10.7-25.1)
4-day	3.31 (2.74-3.96)	4.15 (3.43-4.96)	5.51 (4.54-6.62)	6.64 (5.43-8.04)	8.20 (6.50-10.6)	9.34 (7.25-12.5)	10.6 (8.04-15.0)	12.3 (8.52-17.5)	15.1 (9.98-22.3)	17.5 (11.3-26.5)
7-day	3.94 (3.29-4.67)	4.87 (4.06-5.77)	6.38 (5.30-7.60)	7.64 (6.30-9.17)	9.37 (7.47-12.0)	10.6 (8.30-14.1)	12.0 (9.14-16.8)	13.9 (9.65-19.6)	16.8 (11.2-24.8)	19.5 (12.6-29.3)
10-day	4.57 (3.84-5.39)	5.54 (4.65-6.54)	7.14 (5.96-8.46)	8.46 (7.02-10.1)	10.3 (8.23-13.1)	11.6 (9.09-15.3)	13.1 (9.94-18.2)	15.0 (10.5-21.0)	18.0 (12.0-26.3)	20.6 (13.3-30.9)
20-day	6.56 (5.57-7.65)	7.59 (6.44-8.87)	9.29 (7.85-10.9)	10.7 (8.97-12.6)	12.6 (10.2-15.8)	14.1 (11.0-18.1)	15.6 (11.8-21.1)	17.4 (12.3-24.2)	20.1 (13.5-29.2)	22.4 (14.6-33.4)
30-day	8.23 (7.04-9.54)	9.30 (7.94-10.8)	11.0 (9.40-12.9)	12.5 (10.6-14.7)	14.5 (11.7-17.9)	16.0 (12.6-20.4)	17.6 (13.2-23.4)	19.3 (13.7-26.7)	21.7 (14.6-31.4)	23.7 (15.4-35.2)
45-day	10.3 (8.87-11.9)	11.4 (9.82-13.2)	13.3 (11.3-15.4)	14.8 (12.6-17.3)	16.9 (13.7-20.7)	18.5 (14.6-23.3)	20.1 (15.1-26.4)	21.7 (15.4-29.8)	23.9 (16.1-34.4)	25.5 (16.7-37.8)
60-day	12.0 (10.4-13.8)	13.2 (11.4-15.2)	15.1 (13.0-17.5)	16.7 (14.3-19.4)	18.9 (15.4-23.0)	20.6 (16.3-25.8)	22.3 (16.8-29.0)	23.9 (17.0-32.7)	25.9 (17.5-37.1)	27.3 (17.9-40.4)

<sup>1</sup> Precipitation frequency (PF) estimates in this table are based on frequency analysis of partial duration series (PDS).

Numbers in parenthesis are PF estimates at lower and upper bounds of the 90% confidence interval. The probability that precipitation frequency estimates (for a given duration and average recurrence interval) will be greater than the upper bound (or less than the lower bound) is 5%. Estimates at upper bounds are not checked against probable maximum precipitation (PMP) estimates and may be higher than currently valid PMP values.

Please refer to NOAA Atlas 14 document for more information.

[Back to Top](#)

PF graphical

PDS-based depth-duration-frequency (DDF) curves  
 Latitude: 42.2435°, Longitude: -72.5582°

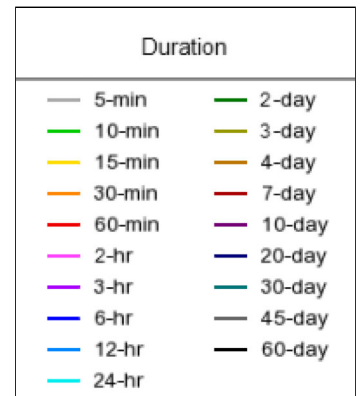
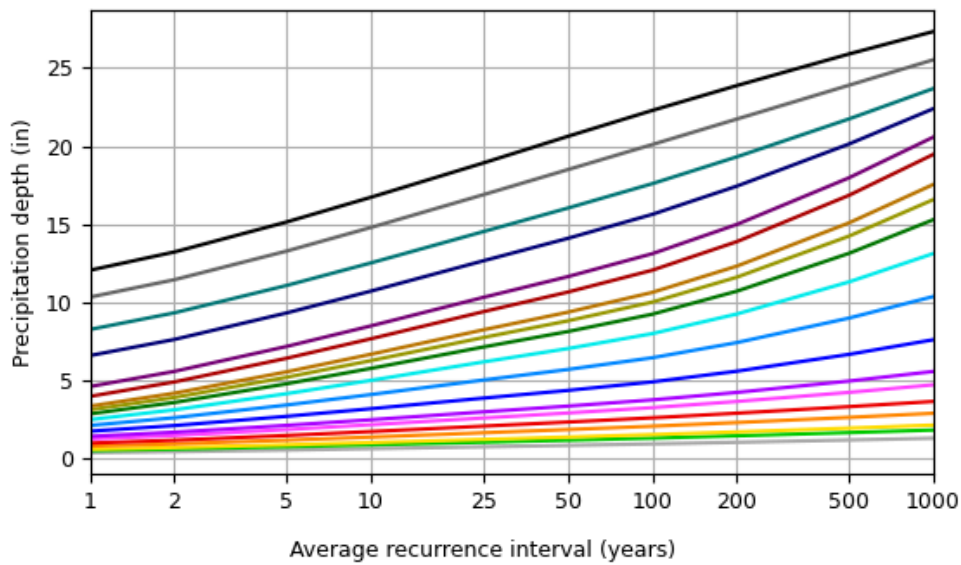
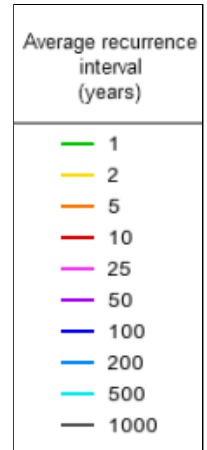
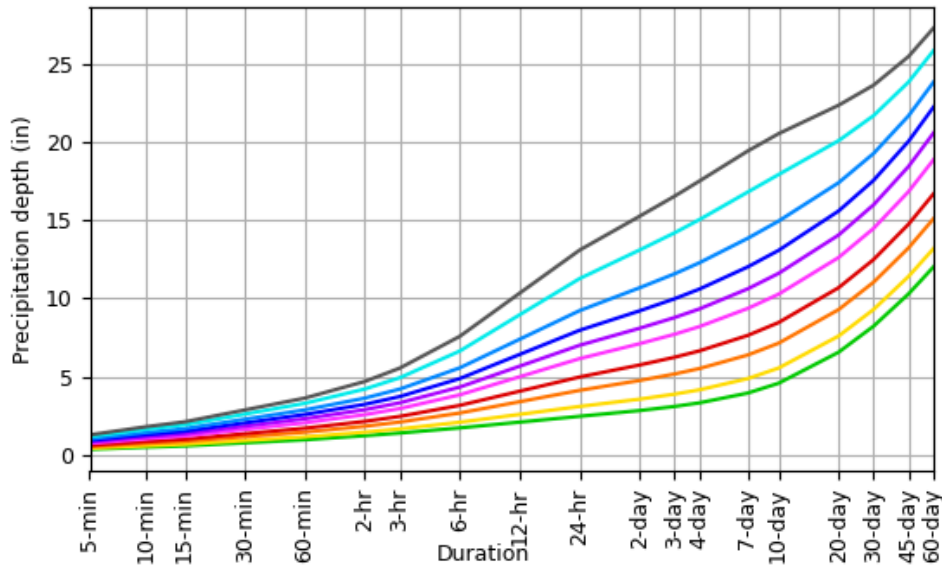

[Back to Top](#)

**Maps & aerials**

Small scale terrain

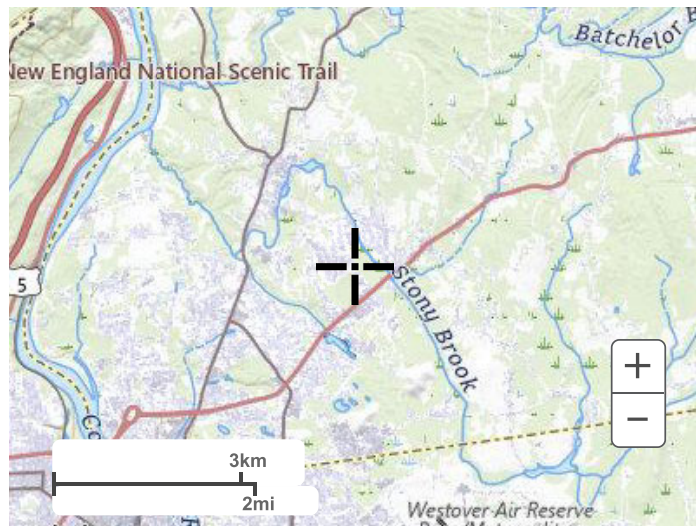

Large scale terrain



Large scale map



Large scale aerial



[Back to Top](#)

---

[US Department of Commerce](#)  
[National Oceanic and Atmospheric Administration](#)  
[National Weather Service](#)  
[National Water Center](#)  
1325 East West Highway  
Silver Spring, MD 20910  
Questions?: [HDSC.Questions@noaa.gov](mailto:HDSC.Questions@noaa.gov)

[Disclaimer](#)

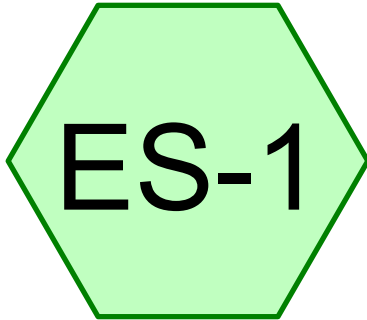

WETLAND

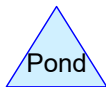
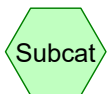

**250511 - PRE (Tc-50)**

Prepared by R Levesque Associates

HydroCAD® 10.20-7a s/n 13073 © 2025 HydroCAD Software Solutions LLC

Printed 12/8/2025

Page 2

**Rainfall Events Listing**

Event#	Event Name	Storm Type	Curve	Mode	Duration (hours)	B/B	Depth (inches)	AMC
1	2-Year	Type III 24-hr		Default	24.00	1	3.08	2
2	10-Year	Type III 24-hr		Default	24.00	1	4.97	2
3	100-Year	Type III 24-hr		Default	24.00	1	7.96	2

**250511 - PRE (Tc-50)**

Type III 24-hr 2-Year Rainfall=3.08"

Prepared by R Levesque Associates

Printed 12/8/2025

HydroCAD® 10.20-7a s/n 13073 © 2025 HydroCAD Software Solutions LLC

Page 3

Time span=0.00-36.00 hrs, dt=0.05 hrs, 721 points  
Runoff by SCS TR-20 method, UH=SCS, Weighted-Q  
Reach routing by Stor-Ind+Trans method - Pond routing by Stor-Ind method

**Subcatchment ES-1:**

Runoff Area=232,202 sf 1.20% Impervious Runoff Depth=0.26"  
Flow Length=491' Tc=17.4 min CN=WQ Runoff=0.5 cfs 5,108 cf

**Link DP-1: WETLAND**

Inflow=0.5 cfs 5,108 cf  
Primary=0.5 cfs 5,108 cf

**Total Runoff Area = 232,202 sf Runoff Volume = 5,108 cf Average Runoff Depth = 0.26"**  
**98.80% Pervious = 229,416 sf 1.20% Impervious = 2,787 sf**

**250511 - PRE (Tc-50)**

Prepared by R Levesque Associates

HydroCAD® 10.20-7a s/n 13073 © 2025 HydroCAD Software Solutions LLC

Type III 24-hr 2-Year Rainfall=3.08"

Printed 12/8/2025

Page 4

**Summary for Subcatchment ES-1:**

Runoff = 0.5 cfs @ 12.48 hrs, Volume= 5,108 cf, Depth= 0.26"  
 Routed to Link DP-1 : WETLAND

Runoff by SCS TR-20 method, UH=SCS, Weighted-Q, Time Span= 0.00-36.00 hrs, dt= 0.05 hrs  
 Type III 24-hr 2-Year Rainfall=3.08"

Area (sf)	CN	Description
11,300	61	>75% Grass cover, Good, HSG B
234	74	>75% Grass cover, Good, HSG C
2,787	98	Roofs, HSG B
215,147	55	Woods, Good, HSG B
2,734	70	Woods, Good, HSG C
232,202		Weighted Average
229,416	55	98.80% Pervious Area
2,787	98	1.20% Impervious Area

Tc (min)	Length (feet)	Slope (ft/ft)	Velocity (ft/sec)	Capacity (cfs)	Description
9.7	50	0.0400	0.09		<b>Sheet Flow,</b> Woods: Light underbrush n= 0.400 P2= 3.00"
7.7	441	0.0360	0.95		<b>Shallow Concentrated Flow,</b> Woodland Kv= 5.0 fps
17.4	491	Total			

**Subcatchment ES-1:**

Hydrograph

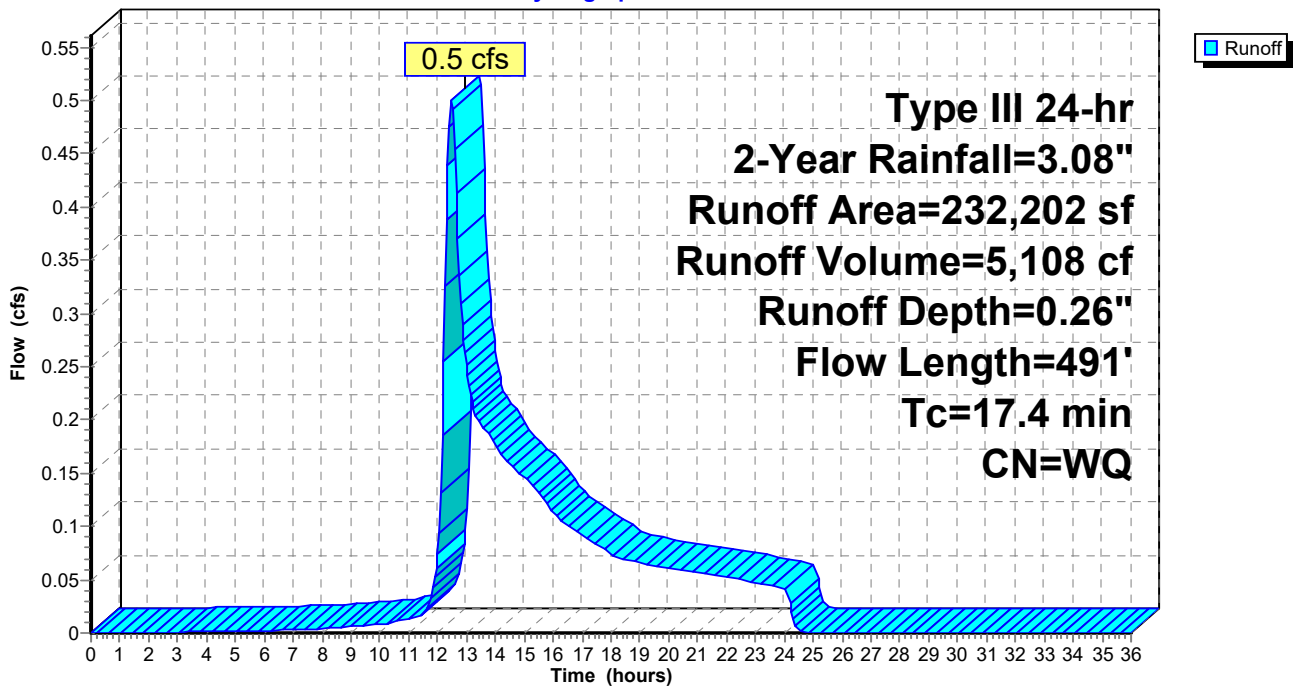

### Summary for Link DP-1: WETLAND

Inflow Area = 232,202 sf, 1.20% Impervious, Inflow Depth = 0.26" for 2-Year event  
Inflow = 0.5 cfs @ 12.48 hrs, Volume= 5,108 cf  
Primary = 0.5 cfs @ 12.48 hrs, Volume= 5,108 cf, Atten= 0%, Lag= 0.0 min

Primary outflow = Inflow, Time Span= 0.00-36.00 hrs, dt= 0.05 hrs

### Link DP-1: WETLAND

Hydrograph

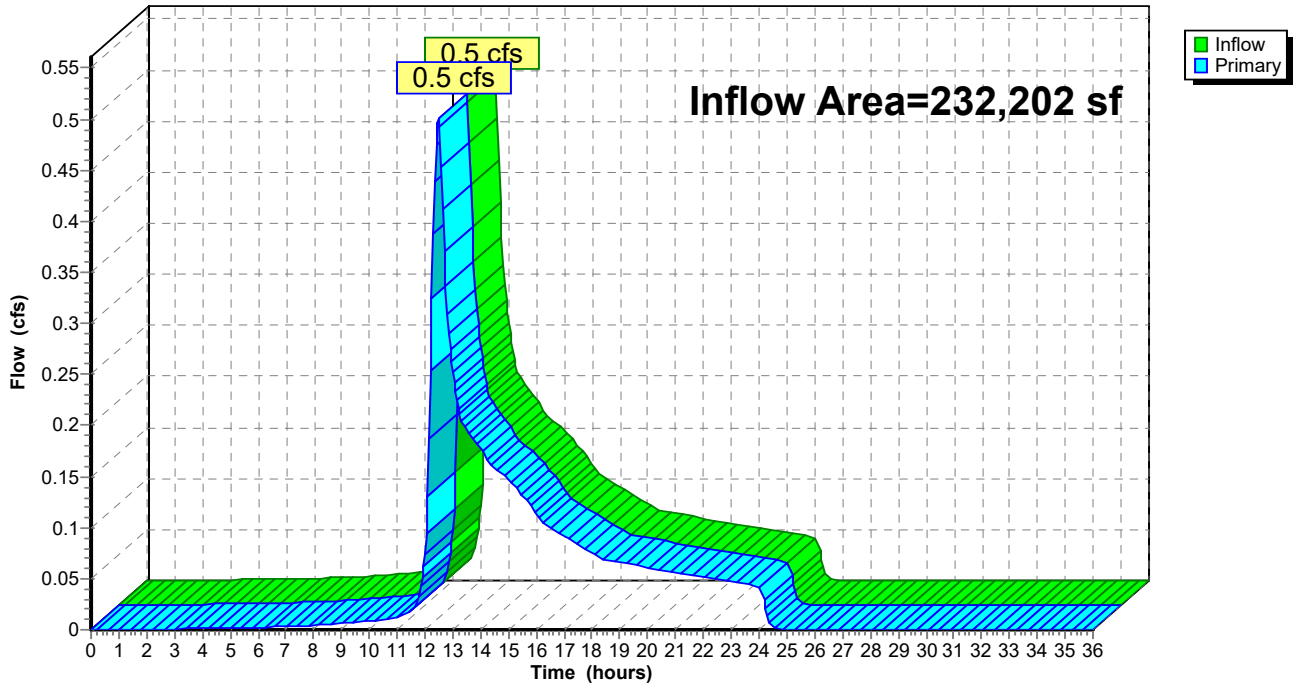

**250511 - PRE (Tc-50)**

*Type III 24-hr 10-Year Rainfall=4.97"*

Prepared by R Levesque Associates

Printed 12/8/2025

HydroCAD® 10.20-7a s/n 13073 © 2025 HydroCAD Software Solutions LLC

Page 6

Time span=0.00-36.00 hrs, dt=0.05 hrs, 721 points  
Runoff by SCS TR-20 method, UH=SCS, Weighted-Q  
Reach routing by Stor-Ind+Trans method - Pond routing by Stor-Ind method

**Subcatchment ES-1:**

Runoff Area=232,202 sf 1.20% Impervious Runoff Depth=1.04"  
Flow Length=491' Tc=17.4 min CN=WQ Runoff=3.7 cfs 20,179 cf

**Link DP-1: WETLAND**

Inflow=3.7 cfs 20,179 cf  
Primary=3.7 cfs 20,179 cf

**Total Runoff Area = 232,202 sf Runoff Volume = 20,179 cf Average Runoff Depth = 1.04"**  
**98.80% Pervious = 229,416 sf 1.20% Impervious = 2,787 sf**

**Summary for Subcatchment ES-1:**

Runoff = 3.7 cfs @ 12.29 hrs, Volume= 20,179 cf, Depth= 1.04"  
 Routed to Link DP-1 : WETLAND

Runoff by SCS TR-20 method, UH=SCS, Weighted-Q, Time Span= 0.00-36.00 hrs, dt= 0.05 hrs  
 Type III 24-hr 10-Year Rainfall=4.97"

Area (sf)	CN	Description
11,300	61	>75% Grass cover, Good, HSG B
234	74	>75% Grass cover, Good, HSG C
2,787	98	Roofs, HSG B
215,147	55	Woods, Good, HSG B
2,734	70	Woods, Good, HSG C
232,202		Weighted Average
229,416	55	98.80% Pervious Area
2,787	98	1.20% Impervious Area

Tc (min)	Length (feet)	Slope (ft/ft)	Velocity (ft/sec)	Capacity (cfs)	Description
9.7	50	0.0400	0.09		<b>Sheet Flow,</b> Woods: Light underbrush n= 0.400 P2= 3.00"
7.7	441	0.0360	0.95		<b>Shallow Concentrated Flow,</b> Woodland Kv= 5.0 fps
17.4	491	Total			

**Subcatchment ES-1:**

Hydrograph

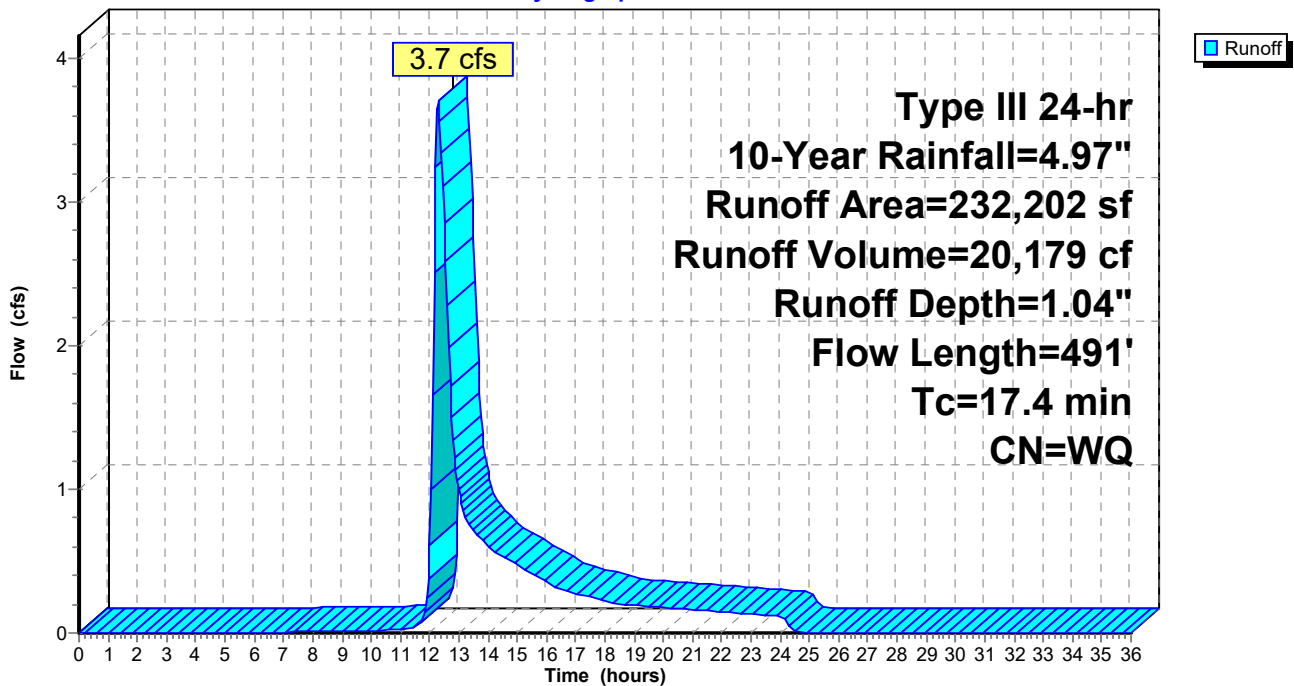

### Summary for Link DP-1: WETLAND

Inflow Area = 232,202 sf, 1.20% Impervious, Inflow Depth = 1.04" for 10-Year event  
Inflow = 3.7 cfs @ 12.29 hrs, Volume= 20,179 cf  
Primary = 3.7 cfs @ 12.29 hrs, Volume= 20,179 cf, Atten= 0%, Lag= 0.0 min

Primary outflow = Inflow, Time Span= 0.00-36.00 hrs, dt= 0.05 hrs

### Link DP-1: WETLAND

Hydrograph

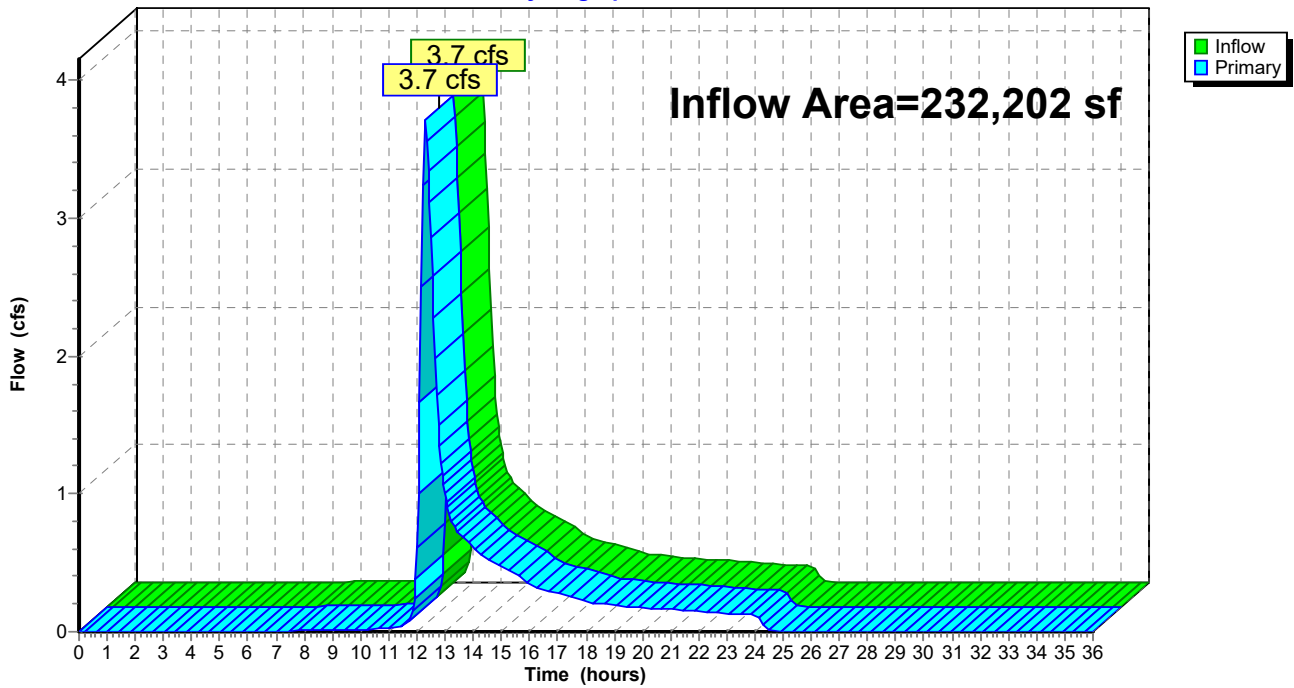

**250511 - PRE (Tc-50)**

Type III 24-hr 100-Year Rainfall=7.96"

Prepared by R Levesque Associates

Printed 12/8/2025

HydroCAD® 10.20-7a s/n 13073 © 2025 HydroCAD Software Solutions LLC

Page 9

Time span=0.00-36.00 hrs, dt=0.05 hrs, 721 points  
Runoff by SCS TR-20 method, UH=SCS, Weighted-Q  
Reach routing by Stor-Ind+Trans method - Pond routing by Stor-Ind method

**Subcatchment ES-1:**

Runoff Area=232,202 sf 1.20% Impervious Runoff Depth=2.87"  
Flow Length=491' Tc=17.4 min CN=WQ Runoff=12.2 cfs 55,539 cf

**Link DP-1: WETLAND**

Inflow=12.2 cfs 55,539 cf  
Primary=12.2 cfs 55,539 cf

**Total Runoff Area = 232,202 sf Runoff Volume = 55,539 cf Average Runoff Depth = 2.87"**  
**98.80% Pervious = 229,416 sf 1.20% Impervious = 2,787 sf**

**250511 - PRE (Tc-50)**

Prepared by R Levesque Associates

HydroCAD® 10.20-7a s/n 13073 © 2025 HydroCAD Software Solutions LLC

Type III 24-hr 100-Year Rainfall=7.96"

Printed 12/8/2025

Page 10

**Summary for Subcatchment ES-1:**

Runoff = 12.2 cfs @ 12.26 hrs, Volume= 55,539 cf, Depth= 2.87"  
 Routed to Link DP-1 : WETLAND

Runoff by SCS TR-20 method, UH=SCS, Weighted-Q, Time Span= 0.00-36.00 hrs, dt= 0.05 hrs  
 Type III 24-hr 100-Year Rainfall=7.96"

Area (sf)	CN	Description
11,300	61	>75% Grass cover, Good, HSG B
234	74	>75% Grass cover, Good, HSG C
2,787	98	Roofs, HSG B
215,147	55	Woods, Good, HSG B
2,734	70	Woods, Good, HSG C
232,202		Weighted Average
229,416	55	98.80% Pervious Area
2,787	98	1.20% Impervious Area

Tc (min)	Length (feet)	Slope (ft/ft)	Velocity (ft/sec)	Capacity (cfs)	Description
9.7	50	0.0400	0.09		<b>Sheet Flow,</b> Woods: Light underbrush n= 0.400 P2= 3.00"
7.7	441	0.0360	0.95		<b>Shallow Concentrated Flow,</b> Woodland Kv= 5.0 fps
17.4	491	Total			

**Subcatchment ES-1:**

Hydrograph

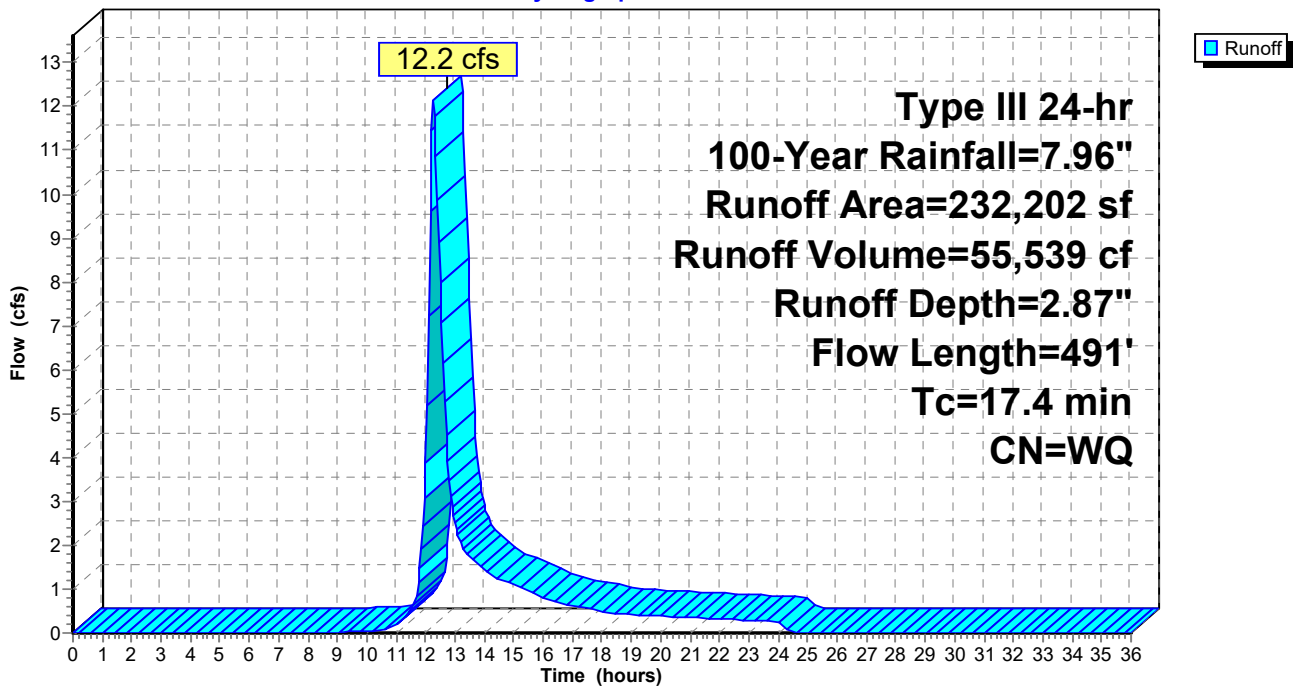

### Summary for Link DP-1: WETLAND

Inflow Area = 232,202 sf, 1.20% Impervious, Inflow Depth = 2.87" for 100-Year event  
Inflow = 12.2 cfs @ 12.26 hrs, Volume= 55,539 cf  
Primary = 12.2 cfs @ 12.26 hrs, Volume= 55,539 cf, Atten= 0%, Lag= 0.0 min

Primary outflow = Inflow, Time Span= 0.00-36.00 hrs, dt= 0.05 hrs

### Link DP-1: WETLAND

Hydrograph

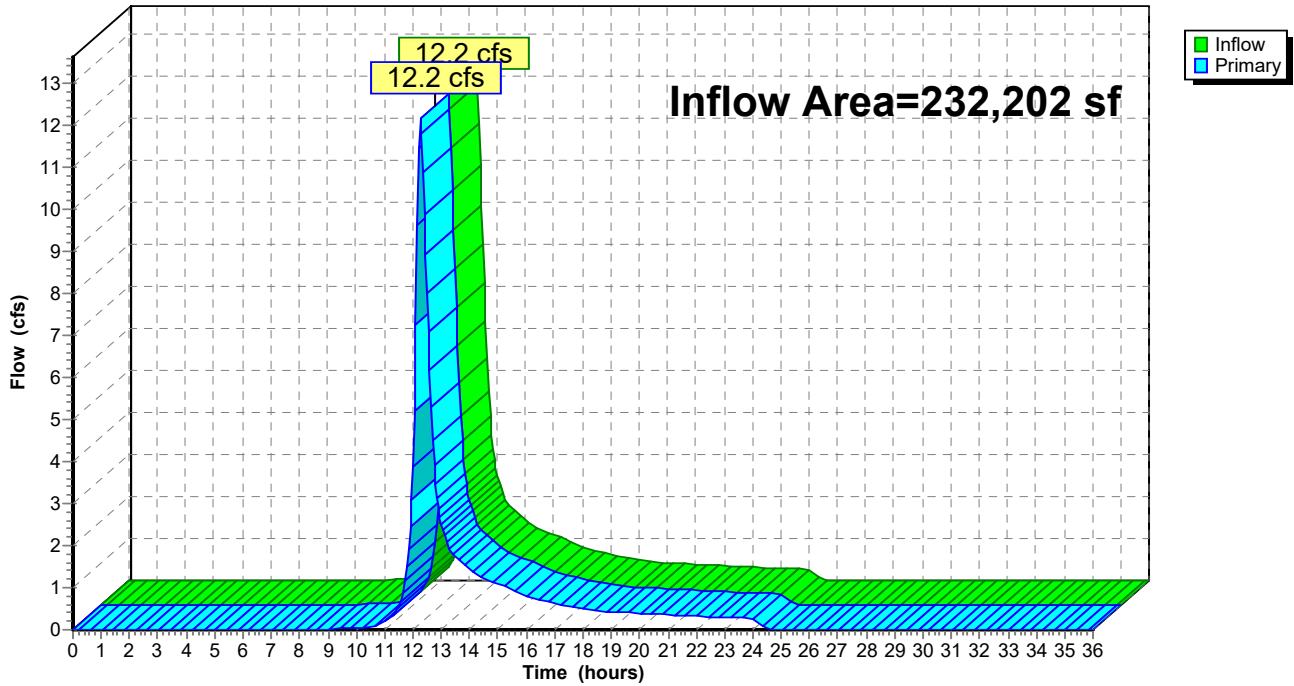



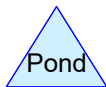
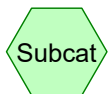
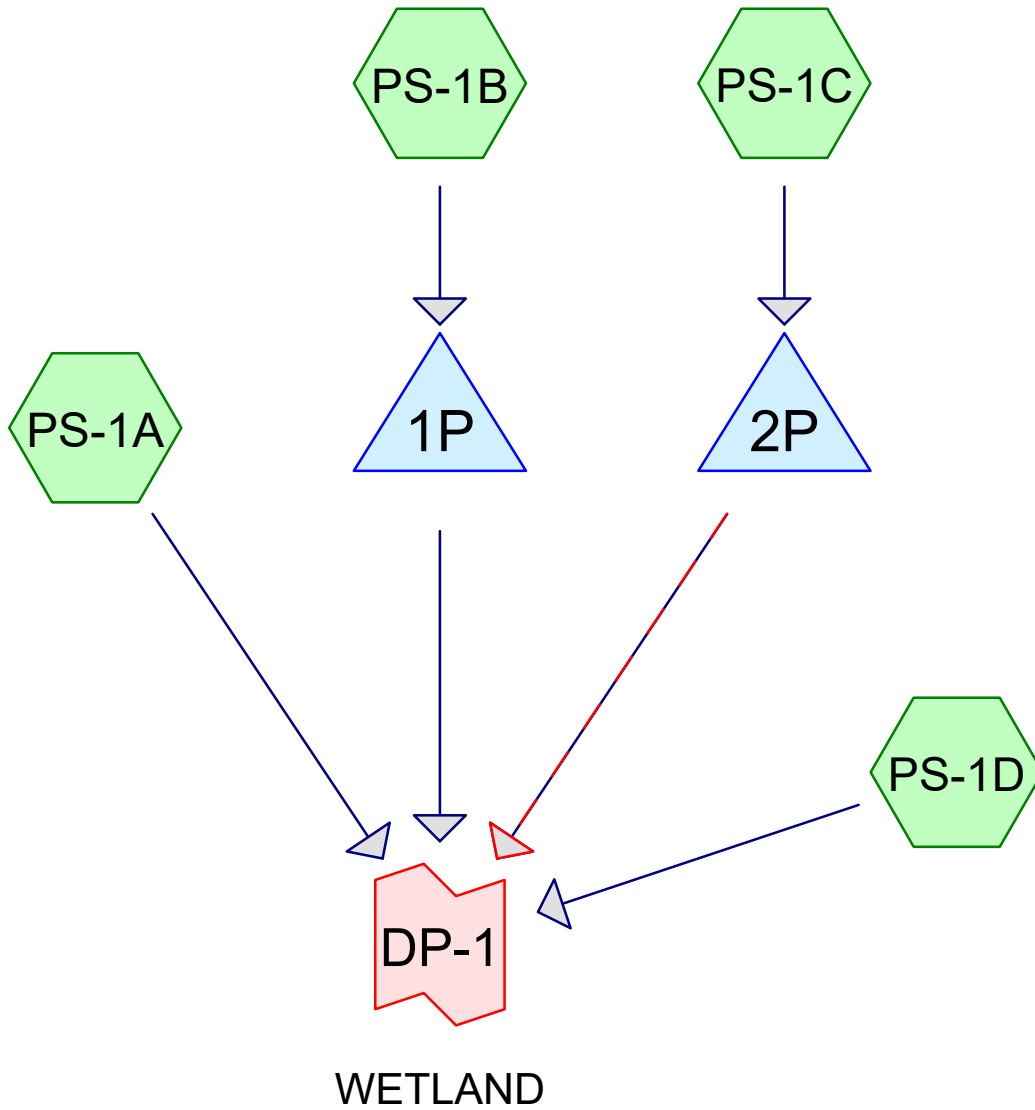

**250511 - POST (Tc-50)**

Prepared by R Levesque Associates

HydroCAD® 10.20-7a s/n 13073 © 2025 HydroCAD Software Solutions LLC

Printed 12/8/2025

Page 2

**Rainfall Events Listing**

Event#	Event Name	Storm Type	Curve	Mode	Duration (hours)	B/B	Depth (inches)	AMC
1	2-Year	Type III 24-hr		Default	24.00	1	3.08	2
2	10-Year	Type III 24-hr		Default	24.00	1	4.97	2
3	100-Year	Type III 24-hr		Default	24.00	1	7.96	2

**250511 - POST (Tc-50)**

Type III 24-hr 2-Year Rainfall=3.08"

Prepared by R Levesque Associates

Printed 12/8/2025

HydroCAD® 10.20-7a s/n 13073 © 2025 HydroCAD Software Solutions LLC

Page 3

Time span=0.00-36.00 hrs, dt=0.05 hrs, 721 points  
Runoff by SCS TR-20 method, UH=SCS, Weighted-Q  
Reach routing by Stor-Ind+Trans method - Pond routing by Stor-Ind method

**Subcatchment PS-1A:** Runoff Area=29,240 sf 3.45% Impervious Runoff Depth=0.47"  
Flow Length=234' Tc=11.4 min CN=WQ Runoff=0.2 cfs 1,139 cf

**Subcatchment PS-1B:** Runoff Area=75,952 sf 73.70% Impervious Runoff Depth=2.20"  
Tc=6.0 min CN=WQ Runoff=3.9 cfs 13,945 cf

**Subcatchment PS-1C:** Runoff Area=17,021 sf 0.00% Impervious Runoff Depth=0.39"  
Flow Length=340' Tc=12.4 min CN=WQ Runoff=0.1 cfs 556 cf

**Subcatchment PS-1D:** Runoff Area=109,989 sf 0.00% Impervious Runoff Depth=0.26"  
Flow Length=371' Tc=6.0 min CN=WQ Runoff=0.3 cfs 2,401 cf

**Pond 1P:** Peak Elev=233.91' Storage=6,173 cf Inflow=3.9 cfs 13,945 cf  
Discarded=0.2 cfs 13,945 cf Primary=0.0 cfs 0 cf Outflow=0.2 cfs 13,945 cf

**Pond 2P:** Peak Elev=226.28' Storage=210 cf Inflow=0.1 cfs 556 cf  
Primary=0.0 cfs 548 cf Secondary=0.0 cfs 0 cf Outflow=0.0 cfs 548 cf

**Link DP-1: WETLAND** Inflow=0.5 cfs 4,089 cf  
Primary=0.5 cfs 4,089 cf

**Total Runoff Area = 232,202 sf Runoff Volume = 18,041 cf Average Runoff Depth = 0.93"**  
**75.46% Pervious = 175,212 sf 24.54% Impervious = 56,990 sf**

**250511 - POST (Tc-50)**

Prepared by R Levesque Associates

HydroCAD® 10.20-7a s/n 13073 © 2025 HydroCAD Software Solutions LLC

Type III 24-hr 2-Year Rainfall=3.08"

Printed 12/8/2025

Page 4

**Summary for Subcatchment PS-1A:**

Runoff = 0.2 cfs @ 12.21 hrs, Volume= 1,139 cf, Depth= 0.47"  
 Routed to Link DP-1 : WETLAND

Runoff by SCS TR-20 method, UH=SCS, Weighted-Q, Time Span= 0.00-36.00 hrs, dt= 0.05 hrs  
 Type III 24-hr 2-Year Rainfall=3.08"

Area (sf)	CN	Description
16,864	61	>75% Grass cover, Good, HSG B
234	74	>75% Grass cover, Good, HSG C
1,009	98	Roofs, HSG B
8,399	55	Woods, Good, HSG B
2,734	70	Woods, Good, HSG C
29,240		Weighted Average
28,231	60	96.55% Pervious Area
1,009	98	3.45% Impervious Area

Tc (min)	Length (feet)	Slope (ft/ft)	Velocity (ft/sec)	Capacity (cfs)	Description
7.3	50	0.0800	0.11		<b>Sheet Flow,</b> Woods: Light underbrush n= 0.400 P2= 3.00"
4.1	184	0.0224	0.75		<b>Shallow Concentrated Flow,</b> Woodland Kv= 5.0 fps
11.4	234	Total			

**Subcatchment PS-1A:**

Hydrograph

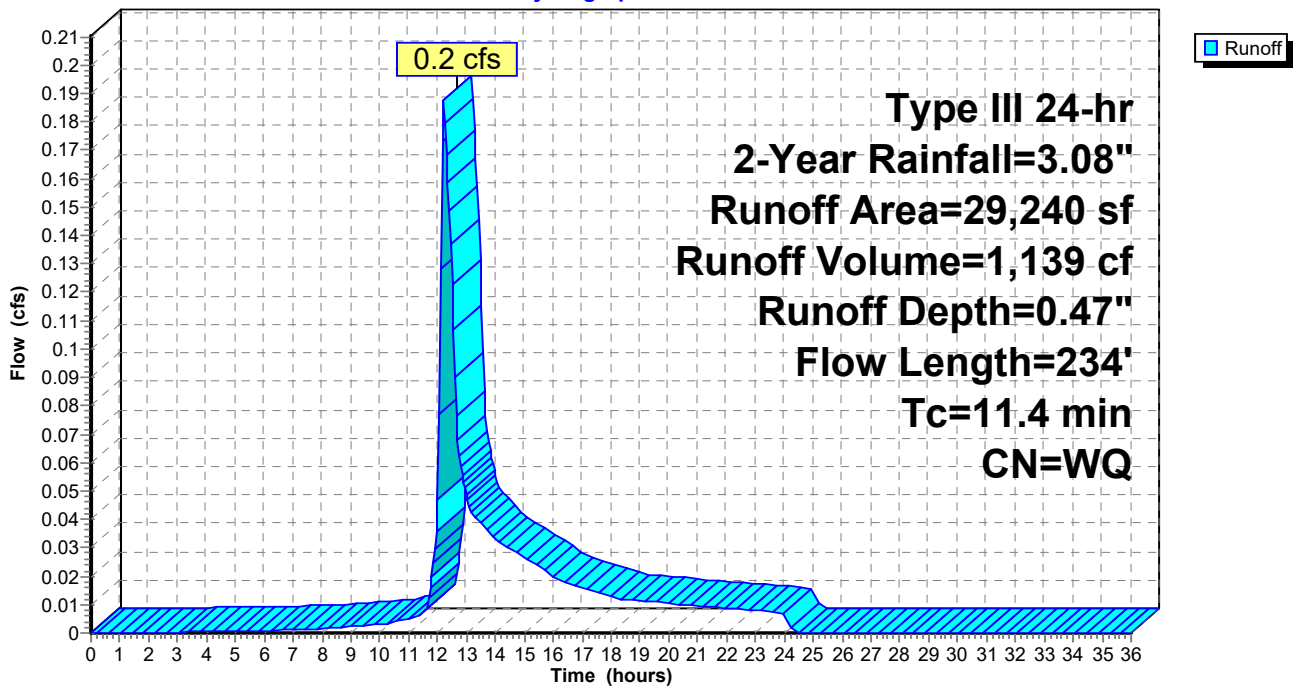

**250511 - POST (Tc-50)**

Prepared by R Levesque Associates

HydroCAD® 10.20-7a s/n 13073 © 2025 HydroCAD Software Solutions LLC

Type III 24-hr 2-Year Rainfall=3.08"

Printed 12/8/2025

Page 5

**Summary for Subcatchment PS-1B:**

Runoff = 3.9 cfs @ 12.09 hrs, Volume= 13,945 cf, Depth= 2.20"  
 Routed to Pond 1P :

Runoff by SCS TR-20 method, UH=SCS, Weighted-Q, Time Span= 0.00-36.00 hrs, dt= 0.05 hrs  
 Type III 24-hr 2-Year Rainfall=3.08"

Area (sf)	CN	Description
19,972	61	>75% Grass cover, Good, HSG B
27,201	98	Paved parking, HSG B
28,779	98	Roofs, HSG B
<hr/>		
75,952		Weighted Average
19,972	61	26.30% Pervious Area
55,980	98	73.70% Impervious Area

Tc (min)	Length (feet)	Slope (ft/ft)	Velocity (ft/sec)	Capacity (cfs)	Description
6.0					Direct Entry,

**Subcatchment PS-1B:**

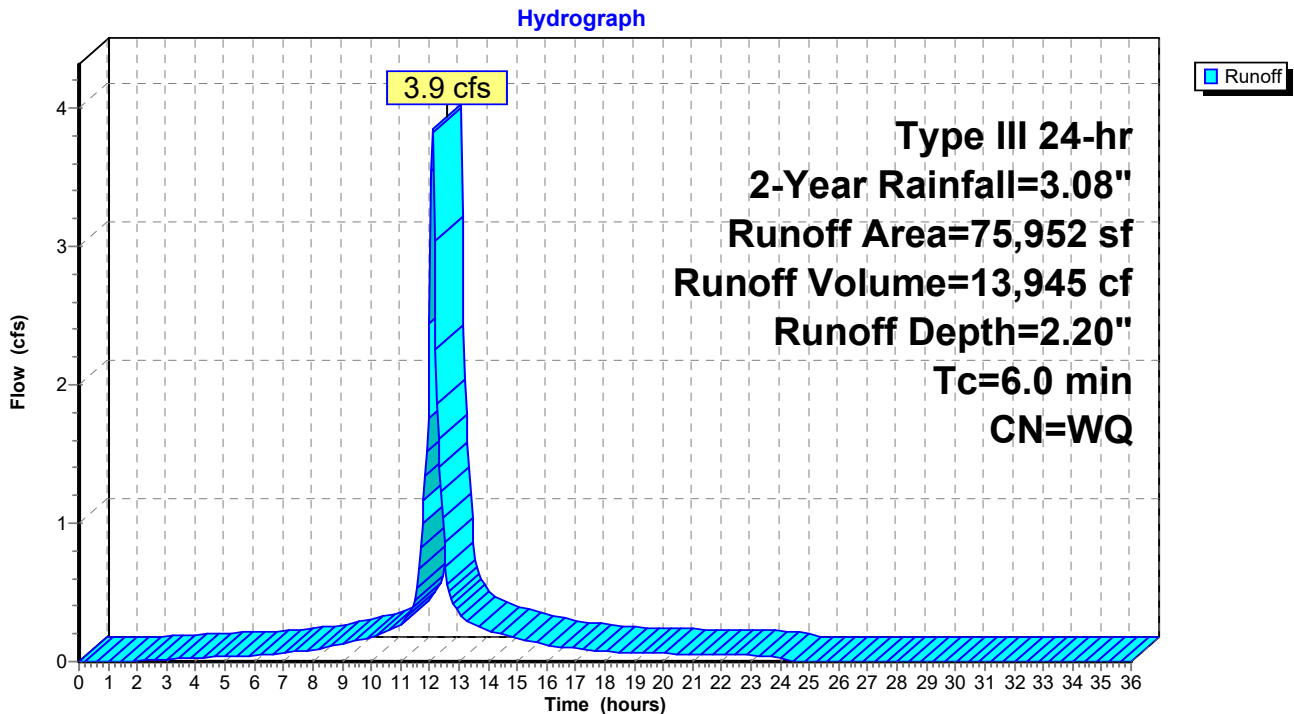

**Summary for Subcatchment PS-1C:**

Runoff = 0.1 cfs @ 12.27 hrs, Volume= 556 cf, Depth= 0.39"  
 Routed to Pond 2P :

Runoff by SCS TR-20 method, UH=SCS, Weighted-Q, Time Span= 0.00-36.00 hrs, dt= 0.05 hrs  
 Type III 24-hr 2-Year Rainfall=3.08"

Area (sf)	CN	Description
16,656	61	>75% Grass cover, Good, HSG B
364	55	Woods, Good, HSG B
17,021		Weighted Average
17,021	61	100.00% Pervious Area

Tc (min)	Length (feet)	Slope (ft/ft)	Velocity (ft/sec)	Capacity (cfs)	Description
11.0	50	0.0300	0.08		Sheet Flow, Grass: Bermuda n= 0.410 P2= 3.00"
1.4	290	0.0458	3.45		Shallow Concentrated Flow, Unpaved Kv= 16.1 fps
12.4	340	Total			

**Subcatchment PS-1C:**

Hydrograph

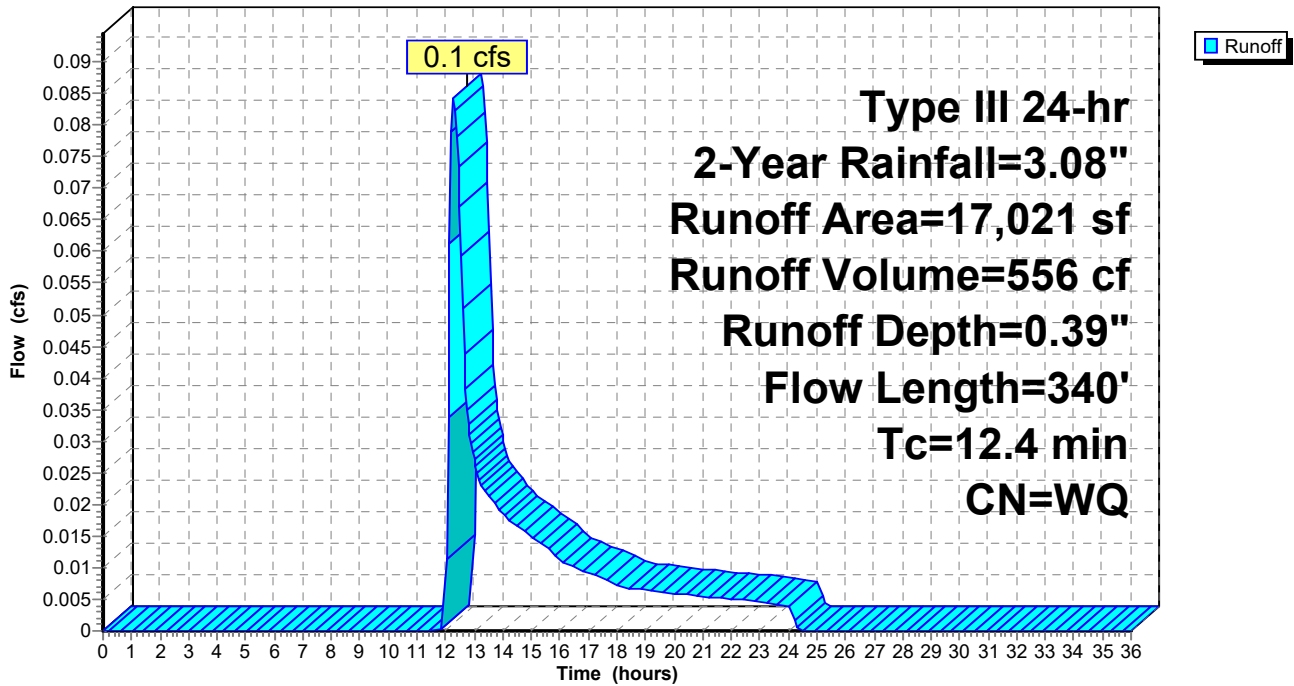

**250511 - POST (Tc-50)**

Prepared by R Levesque Associates

HydroCAD® 10.20-7a s/n 13073 © 2025 HydroCAD Software Solutions LLC

Type III 24-hr 2-Year Rainfall=3.08"

Printed 12/8/2025

Page 7

**Summary for Subcatchment PS-1D:**

Runoff = 0.3 cfs @ 12.31 hrs, Volume= 2,401 cf, Depth= 0.26"  
 Routed to Link DP-1 : WETLAND

Runoff by SCS TR-20 method, UH=SCS, Weighted-Q, Time Span= 0.00-36.00 hrs, dt= 0.05 hrs  
 Type III 24-hr 2-Year Rainfall=3.08"

Area (sf)	CN	Description
27,867	61	>75% Grass cover, Good, HSG B
0	98	Roofs, HSG B
82,121	55	Woods, Good, HSG B
109,989		Weighted Average
109,989	57	100.00% Pervious Area
0	98	0.00% Impervious Area

Tc (min)	Length (feet)	Slope (ft/ft)	Velocity (ft/sec)	Capacity (cfs)	Description
3.6	50	0.0650	0.23		<b>Sheet Flow,</b> Grass: Short n= 0.150 P2= 3.00"
1.7	321	0.0424	3.09		<b>Shallow Concentrated Flow,</b> Grassed Waterway Kv= 15.0 fps
5.3	371	Total, Increased to minimum Tc = 6.0 min			

**Subcatchment PS-1D:**

Hydrograph

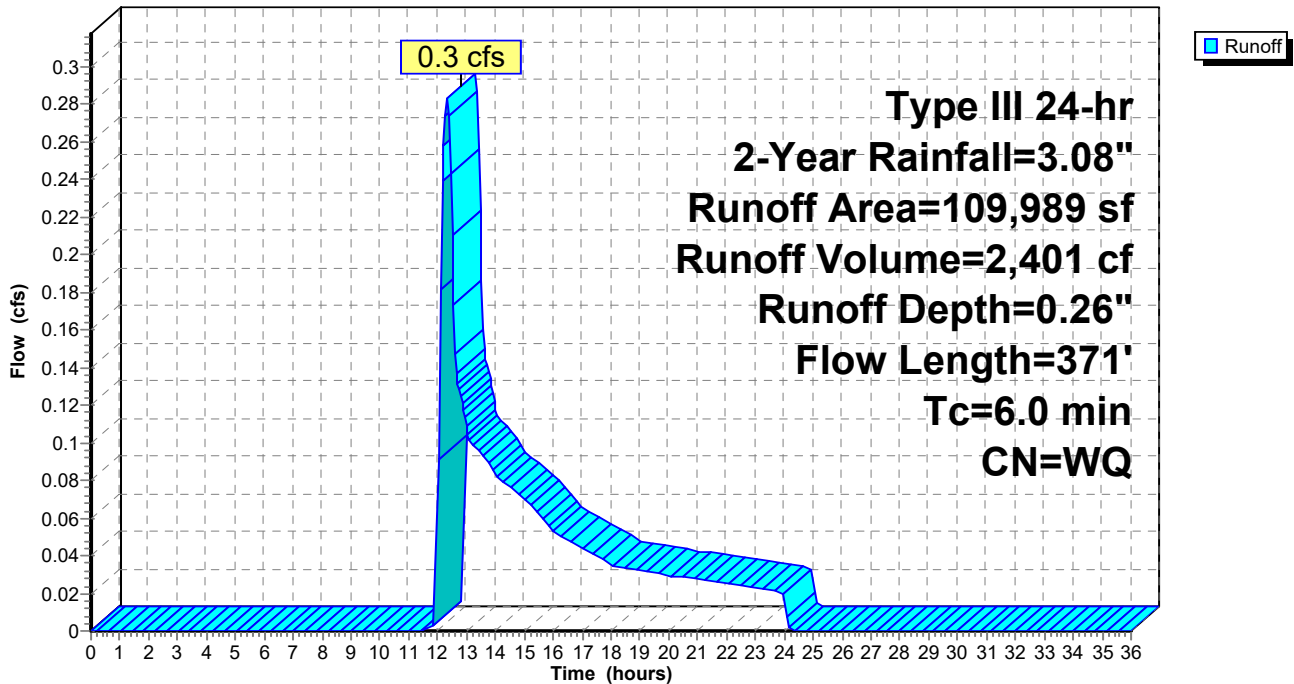

**Summary for Pond 1P:**

Inflow Area = 75,952 sf, 73.70% Impervious, Inflow Depth = 2.20" for 2-Year event  
 Inflow = 3.9 cfs @ 12.09 hrs, Volume= 13,945 cf  
 Outflow = 0.2 cfs @ 10.60 hrs, Volume= 13,945 cf, Atten= 95%, Lag= 0.0 min  
 Discarded = 0.2 cfs @ 10.60 hrs, Volume= 13,945 cf  
 Primary = 0.0 cfs @ 0.00 hrs, Volume= 0 cf  
 Routed to Link DP-1 : WETLAND

Routing by Stor-Ind method, Time Span= 0.00-36.00 hrs, dt= 0.05 hrs  
 Peak Elev= 233.91' @ 14.16 hrs Surf.Area= 8,967 sf Storage= 6,173 cf

Plug-Flow detention time= 247.1 min calculated for 13,925 cf (100% of inflow)  
 Center-of-Mass det. time= 247.0 min ( 1,011.9 - 764.9 )

Volume	Invert	Avail.Storage	Storage Description
#1A	232.83'	8,312 cf	<b>68.00'W x 131.87'L x 3.75'H Field A</b> 33,626 cf Overall - 12,845 cf Embedded = 20,781 cf x 40.0% Voids
#2A	233.33'	12,845 cf	<b>ADS_StormTech SC-800 +Cap x 252 Inside #1</b> Effective Size= 45.0"W x 33.0"H => 7.11 sf x 7.12'L = 50.6 cf Overall Size= 51.0"W x 33.0"H x 7.55'L with 0.43' Overlap 252 Chambers in 14 Rows Cap Storage= 3.4 cf x 2 x 14 rows = 95.8 cf
		21,157 cf	Total Available Storage

Storage Group A created with Chamber Wizard

Device	Routing	Invert	Outlet Devices
#1	Primary	231.83'	<b>12.0" Round Culvert</b> L= 104.0' RCP, groove end projecting, Ke= 0.200 Inlet / Outlet Invert= 231.83' / 229.23' S= 0.0250 1' Cc= 0.900 n= 0.013 Corrugated PE, smooth interior, Flow Area= 0.79 sf
#2	Device 1	235.33'	<b>4.0' long Sharp-Crested Rectangular Weir</b> 2 End Contraction(s)
#3	Device 1	234.83'	<b>3.0" W x 3.0" H Vert. Orifice</b> C= 0.600 Limited to weir flow at low heads
#4	Discarded	232.83'	<b>1.020 in/hr Exfiltration over Surface area</b> Phase-In= 0.01'

**Discarded OutFlow** Max=0.2 cfs @ 10.60 hrs HW=232.87' (Free Discharge)

↳ **4=Exfiltration** (Exfiltration Controls 0.2 cfs)

**Primary OutFlow** Max=0.0 cfs @ 0.00 hrs HW=232.83' (Free Discharge)

↳ **1=Culvert** (Passes 0.0 cfs of 3.3 cfs potential flow)

↳ **2=Sharp-Crested Rectangular Weir** ( Controls 0.0 cfs)

↳ **3=Orifice** ( Controls 0.0 cfs)

**Pond 1P: - Chamber Wizard Field A**

**Chamber Model = ADS\_StormTech SC-800 +Cap (ADS StormTech® SC-800 with cap volume)**

Effective Size= 45.0"W x 33.0"H => 7.11 sf x 7.12'L = 50.6 cf

Overall Size= 51.0"W x 33.0"H x 7.55'L with 0.43' Overlap

Cap Storage= 3.4 cf x 2 x 14 rows = 95.8 cf

51.0" Wide + 6.0" Spacing = 57.0" C-C Row Spacing

18 Chambers/Row x 7.12' Long +0.88' Cap Length x 2 = 129.87' Row Length +12.0" End Stone x 2 = 131.87' Base Length

14 Rows x 51.0" Wide + 6.0" Spacing x 13 + 12.0" Side Stone x 2 = 68.00' Base Width

6.0" Stone Base + 33.0" Chamber Height + 6.0" Stone Cover = 3.75' Field Height

252 Chambers x 50.6 cf + 3.4 cf Cap Volume x 2 x 14 Rows = 12,845.0 cf Chamber Storage

33,626.0 cf Field - 12,845.0 cf Chambers = 20,781.0 cf Stone x 40.0% Voids = 8,312.4 cf Stone Storage

Chamber Storage + Stone Storage = 21,157.4 cf = 0.486 af

Overall Storage Efficiency = 62.9%

Overall System Size = 131.87' x 68.00' x 3.75'

252 Chambers

1,245.4 cy Field

769.7 cy Stone

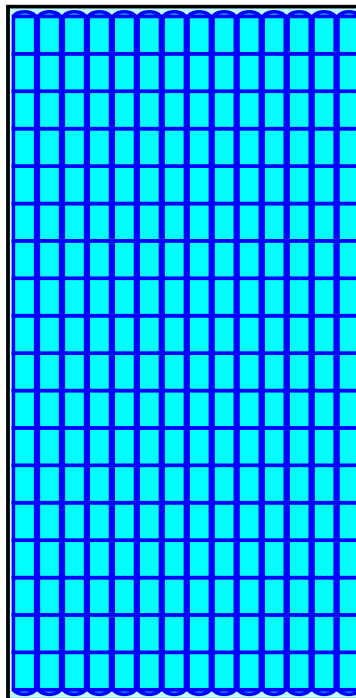

### Pond 1P:

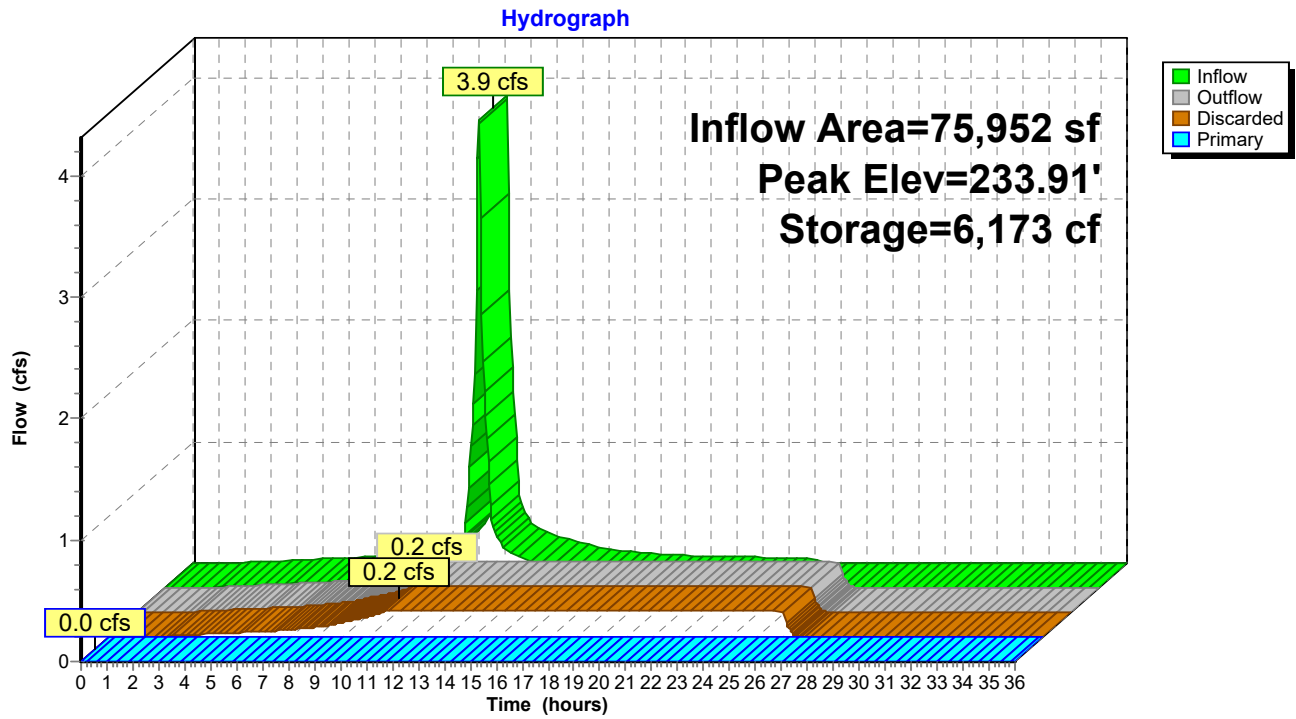

**Stage-Area-Storage for Pond 1P:**

Elevation (feet)	Surface (sq-ft)	Storage (cubic-feet)	Elevation (feet)	Surface (sq-ft)	Storage (cubic-feet)
232.83	<b>8,967</b>	0	235.48	8,967	16,615
232.88	8,967	179	235.53	8,967	16,891
232.93	8,967	359	235.58	8,967	17,160
232.98	8,967	538	235.63	8,967	17,423
233.03	8,967	717	235.68	8,967	17,678
233.08	8,967	897	235.73	8,967	17,923
233.13	8,967	1,076	235.78	8,967	18,157
233.18	8,967	1,255	235.83	8,967	18,379
233.23	8,967	1,435	235.88	8,967	18,590
233.28	8,967	1,614	235.93	8,967	18,793
233.33	8,967	1,793	235.98	8,967	18,990
233.38	8,967	2,176	236.03	8,967	19,180
233.43	8,967	2,557	236.08	8,967	19,364
233.48	8,967	2,938	236.13	8,967	19,543
233.53	8,967	3,317	236.18	8,967	19,723
233.58	8,967	3,695	236.23	8,967	19,902
233.63	8,967	4,072	236.28	8,967	20,081
233.68	8,967	4,448	236.33	8,967	20,261
233.73	8,967	4,822	236.38	8,967	20,440
233.78	8,967	5,195	236.43	8,967	20,619
233.83	8,967	5,567	236.48	8,967	20,799
233.88	8,967	5,937	236.53	8,967	20,978
233.93	8,967	6,306	236.58	8,967	<b>21,157</b>
233.98	8,967	6,673			
234.03	8,967	7,039			
234.08	8,967	7,403			
234.13	8,967	7,765			
234.18	8,967	8,125			
234.23	8,967	8,484			
234.28	8,967	8,841			
234.33	8,967	9,196			
234.38	8,967	9,549			
234.43	8,967	9,900			
234.48	8,967	10,248			
234.53	8,967	10,595			
234.58	8,967	10,939			
234.63	8,967	11,281			
234.68	8,967	11,620			
234.73	8,967	11,957			
234.78	8,967	12,291			
234.83	8,967	12,622			
234.88	8,967	12,950			
234.93	8,967	13,276			
234.98	8,967	13,598			
235.03	8,967	13,917			
235.08	8,967	14,233			
235.13	8,967	14,545			
235.18	8,967	14,854			
235.23	8,967	15,158			
235.28	8,967	15,459			
235.33	8,967	15,755			
235.38	8,967	16,047			
235.43	8,967	16,333			

**Summary for Pond 2P:**

Inflow Area = 17,021 sf, 0.00% Impervious, Inflow Depth = 0.39" for 2-Year event  
 Inflow = 0.1 cfs @ 12.27 hrs, Volume= 556 cf  
 Outflow = 0.0 cfs @ 15.59 hrs, Volume= 548 cf, Atten= 85%, Lag= 199.0 min  
 Primary = 0.0 cfs @ 15.59 hrs, Volume= 548 cf  
 Routed to Link DP-1 : WETLAND  
 Secondary = 0.0 cfs @ 0.00 hrs, Volume= 0 cf  
 Routed to Link DP-1 : WETLAND

Routing by Stor-Ind method, Time Span= 0.00-36.00 hrs, dt= 0.05 hrs  
 Peak Elev= 226.28' @ 15.59 hrs Surf.Area= 809 sf Storage= 210 cf

Plug-Flow detention time= 229.8 min calculated for 548 cf (98% of inflow)  
 Center-of-Mass det. time= 223.3 min ( 1,149.6 - 926.3 )

Volume	Invert	Avail.Storage	Storage Description			
#1	226.00'	2,507 cf	<b>Custom Stage Data (Irregular)</b> Listed below (Recalc)			
Elevation (feet)	Surf.Area (sq-ft)	Perim. (feet)	Inc.Store (cubic-feet)	Cum.Store (cubic-feet)	Wet.Area (sq-ft)	
226.00	668	110.0	0	0	668	
227.00	1,221	151.0	931	931	1,529	
228.00	1,960	196.0	1,576	2,507	2,784	

Device	Routing	Invert	Outlet Devices
#1	Primary	226.00'	<b>6.0" Round Culvert</b> L= 158.0' RCP, groove end projecting, Ke= 0.200 Inlet / Outlet Invert= 226.00' / 225.00' S= 0.0063 ' / Cc= 0.900 n= 0.013 Corrugated PE, smooth interior, Flow Area= 0.20 sf
#2	Device 1	226.00'	<b>1.0" Vert. Orifice</b> C= 0.600 Limited to weir flow at low heads
#3	Device 1	227.00'	<b>4.0' long Sharp-Crested Rectangular Weir</b> 2 End Contraction(s)
#4	Device 1	227.50'	<b>48.0" x 48.0" Horiz. Gate</b> C= 0.600 Limited to weir flow at low heads
#5	Secondary	227.50'	<b>10.0' long x 10.0' breadth Broad-Crested Rectangular Weir</b> Head (feet) 0.20 0.40 0.60 0.80 1.00 1.20 1.40 1.60 Coef. (English) 2.49 2.56 2.70 2.69 2.68 2.69 2.67 2.64

**Primary OutFlow** Max=0.0 cfs @ 15.59 hrs HW=226.28' (Free Discharge)

- ↑ 1=Culvert (Passes 0.0 cfs of 0.2 cfs potential flow)
- ↑ 2=Orifice (Orifice Controls 0.0 cfs @ 2.37 fps)
- ↑ 3=Sharp-Crested Rectangular Weir ( Controls 0.0 cfs)
- ↑ 4=Gate ( Controls 0.0 cfs)

**Secondary OutFlow** Max=0.0 cfs @ 0.00 hrs HW=226.00' (Free Discharge)

- ↑ 5=Broad-Crested Rectangular Weir ( Controls 0.0 cfs)

### Pond 2P:

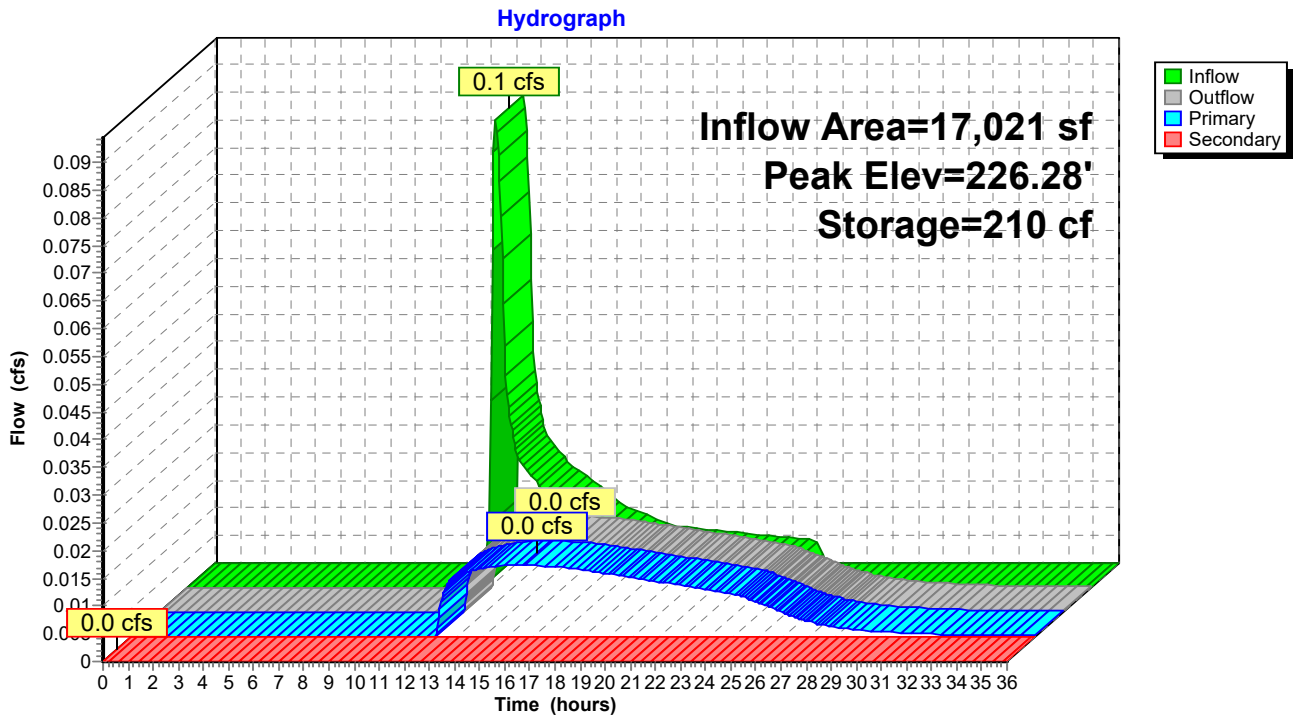

**Stage-Area-Storage for Pond 2P:**

Elevation (feet)	Surface (sq-ft)	Storage (cubic-feet)	Elevation (feet)	Surface (sq-ft)	Storage (cubic-feet)
226.00	668	0	227.06	1,260	1,005
226.02	677	13	227.08	1,274	1,030
226.04	687	27	227.10	1,287	1,056
226.06	697	41	227.12	1,300	1,082
226.08	706	55	227.14	1,314	1,108
226.10	716	69	227.16	1,328	1,135
226.12	726	84	227.18	1,341	1,161
226.14	735	98	227.20	1,355	1,188
226.16	745	113	227.22	1,369	1,215
226.18	755	128	227.24	1,382	1,243
226.20	765	143	227.26	1,396	1,271
226.22	775	159	227.28	1,410	1,299
226.24	786	174	227.30	1,424	1,327
226.26	796	190	227.32	1,439	1,356
226.28	806	206	227.34	1,453	1,385
226.30	817	222	227.36	1,467	1,414
226.32	827	239	227.38	1,481	1,443
226.34	837	255	227.40	1,496	1,473
226.36	848	272	227.42	1,510	1,503
226.38	859	289	227.44	1,525	1,534
226.40	869	307	227.46	1,539	1,564
226.42	880	324	227.48	1,554	1,595
226.44	891	342	227.50	1,569	1,626
226.46	902	360	227.52	1,584	1,658
226.48	913	378	227.54	1,598	1,690
226.50	924	396	227.56	1,613	1,722
226.52	935	415	227.58	1,628	1,754
226.54	946	434	227.60	1,644	1,787
226.56	957	453	227.62	1,659	1,820
226.58	969	472	227.64	1,674	1,853
226.60	980	491	227.66	1,689	1,887
226.62	991	511	227.68	1,705	1,921
226.64	1,003	531	227.70	1,720	1,955
226.66	1,014	551	227.72	1,736	1,990
226.68	1,026	572	227.74	1,751	2,025
226.70	1,038	592	227.76	1,767	2,060
226.72	1,049	613	227.78	1,782	2,095
226.74	1,061	634	227.80	1,798	2,131
226.76	1,073	656	227.82	1,814	2,167
226.78	1,085	677	227.84	1,830	2,204
226.80	1,097	699	227.86	1,846	2,240
226.82	1,109	721	227.88	1,862	2,277
226.84	1,121	743	227.90	1,878	2,315
226.86	1,134	766	227.92	1,894	2,353
226.88	1,146	789	227.94	1,911	2,391
226.90	1,158	812	227.96	1,927	2,429
226.92	1,171	835	227.98	1,944	2,468
226.94	1,183	859	228.00	<b>1,960</b>	<b>2,507</b>
226.96	1,196	882			
226.98	1,208	906			
227.00	1,221	931			
227.02	1,234	955			
227.04	1,247	980			

### Summary for Link DP-1: WETLAND

Inflow Area = 232,202 sf, 24.54% Impervious, Inflow Depth > 0.21" for 2-Year event  
Inflow = 0.5 cfs @ 12.27 hrs, Volume= 4,089 cf  
Primary = 0.5 cfs @ 12.27 hrs, Volume= 4,089 cf, Atten= 0%, Lag= 0.0 min

Primary outflow = Inflow, Time Span= 0.00-36.00 hrs, dt= 0.05 hrs

### Link DP-1: WETLAND

Hydrograph

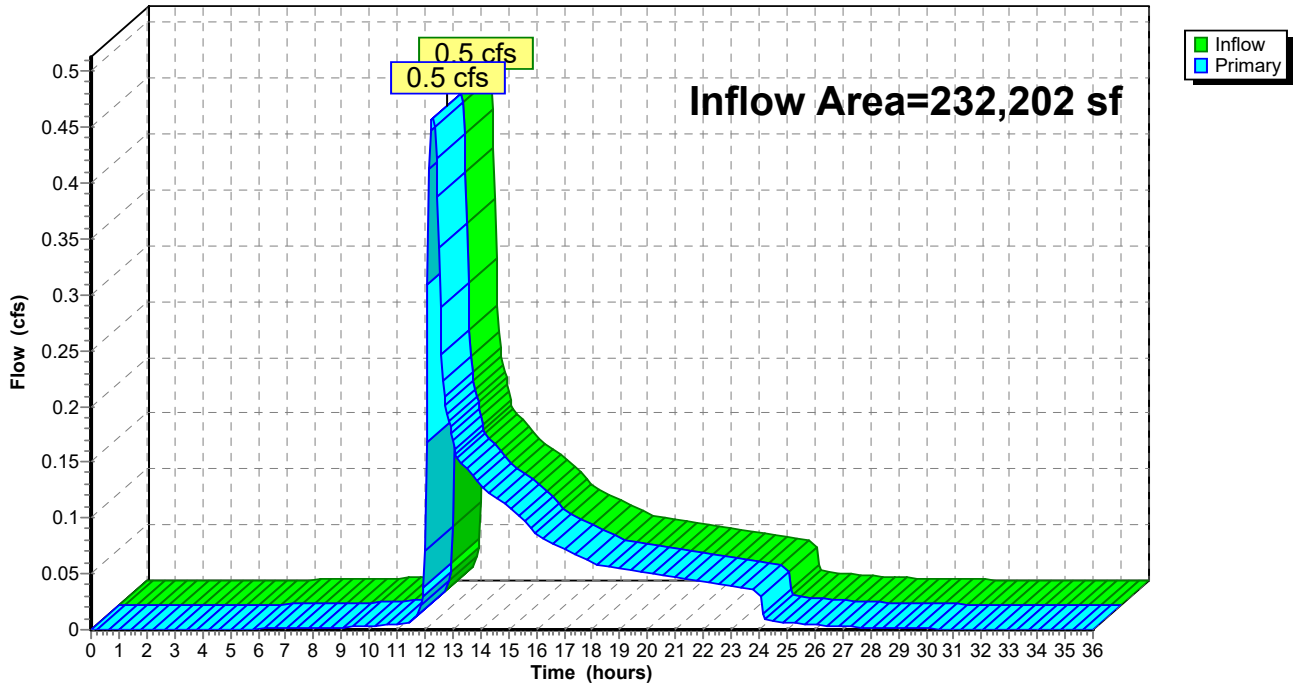

**250511 - POST (Tc-50)**

Type III 24-hr 10-Year Rainfall=4.97"

Prepared by R Levesque Associates

Printed 12/8/2025

HydroCAD® 10.20-7a s/n 13073 © 2025 HydroCAD Software Solutions LLC

Page 16

Time span=0.00-36.00 hrs, dt=0.05 hrs, 721 points  
Runoff by SCS TR-20 method, UH=SCS, Weighted-Q  
Reach routing by Stor-Ind+Trans method - Pond routing by Stor-Ind method

**Subcatchment PS-1A:** Runoff Area=29,240 sf 3.45% Impervious Runoff Depth=1.43"  
Flow Length=234' Tc=11.4 min CN=WQ Runoff=0.8 cfs 3,477 cf

**Subcatchment PS-1B:** Runoff Area=75,952 sf 73.70% Impervious Runoff Depth=3.84"  
Tc=6.0 min CN=WQ Runoff=6.7 cfs 24,329 cf

**Subcatchment PS-1C:** Runoff Area=17,021 sf 0.00% Impervious Runoff Depth=1.34"  
Flow Length=340' Tc=12.4 min CN=WQ Runoff=0.4 cfs 1,905 cf

**Subcatchment PS-1D:** Runoff Area=109,989 sf 0.00% Impervious Runoff Depth=1.06"  
Flow Length=371' Tc=6.0 min CN=WQ Runoff=2.6 cfs 9,742 cf

**Pond 1P:** Peak Elev=234.94' Storage=13,349 cf Inflow=6.7 cfs 24,329 cf  
Discarded=0.2 cfs 22,846 cf Primary=0.0 cfs 307 cf Outflow=0.2 cfs 23,153 cf

**Pond 2P:** Peak Elev=227.01' Storage=947 cf Inflow=0.4 cfs 1,905 cf  
Primary=0.1 cfs 1,847 cf Secondary=0.0 cfs 0 cf Outflow=0.1 cfs 1,847 cf

**Link DP-1: WETLAND** Inflow=3.3 cfs 15,373 cf  
Primary=3.3 cfs 15,373 cf

**Total Runoff Area = 232,202 sf Runoff Volume = 39,453 cf Average Runoff Depth = 2.04"**  
**75.46% Pervious = 175,212 sf 24.54% Impervious = 56,990 sf**

**250511 - POST (Tc-50)**

Prepared by R Levesque Associates  
 HydroCAD® 10.20-7a s/n 13073 © 2025 HydroCAD Software Solutions LLC

Type III 24-hr 10-Year Rainfall=4.97"

Printed 12/8/2025

Page 17

**Summary for Subcatchment PS-1A:**

Runoff = 0.8 cfs @ 12.17 hrs, Volume= 3,477 cf, Depth= 1.43"  
 Routed to Link DP-1 : WETLAND

Runoff by SCS TR-20 method, UH=SCS, Weighted-Q, Time Span= 0.00-36.00 hrs, dt= 0.05 hrs  
 Type III 24-hr 10-Year Rainfall=4.97"

Area (sf)	CN	Description
16,864	61	>75% Grass cover, Good, HSG B
234	74	>75% Grass cover, Good, HSG C
1,009	98	Roofs, HSG B
8,399	55	Woods, Good, HSG B
2,734	70	Woods, Good, HSG C
29,240		Weighted Average
28,231	60	96.55% Pervious Area
1,009	98	3.45% Impervious Area

Tc (min)	Length (feet)	Slope (ft/ft)	Velocity (ft/sec)	Capacity (cfs)	Description
7.3	50	0.0800	0.11		<b>Sheet Flow,</b> Woods: Light underbrush n= 0.400 P2= 3.00"
4.1	184	0.0224	0.75		<b>Shallow Concentrated Flow,</b> Woodland Kv= 5.0 fps
11.4	234	Total			

**Subcatchment PS-1A:**

Hydrograph

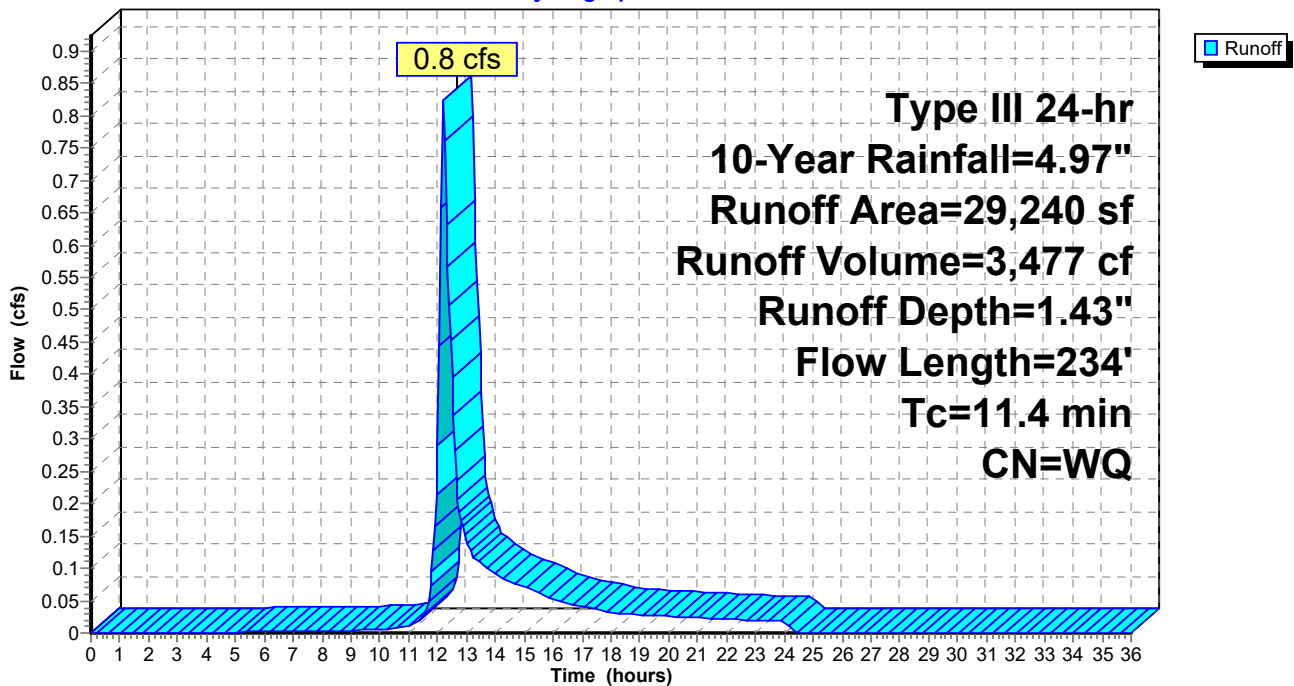

**250511 - POST (Tc-50)**

Prepared by R Levesque Associates

HydroCAD® 10.20-7a s/n 13073 © 2025 HydroCAD Software Solutions LLC

Type III 24-hr 10-Year Rainfall=4.97"

Printed 12/8/2025

Page 18

**Summary for Subcatchment PS-1B:**

Runoff = 6.7 cfs @ 12.09 hrs, Volume= 24,329 cf, Depth= 3.84"  
 Routed to Pond 1P :

Runoff by SCS TR-20 method, UH=SCS, Weighted-Q, Time Span= 0.00-36.00 hrs, dt= 0.05 hrs  
 Type III 24-hr 10-Year Rainfall=4.97"

Area (sf)	CN	Description
19,972	61	>75% Grass cover, Good, HSG B
27,201	98	Paved parking, HSG B
28,779	98	Roofs, HSG B
75,952		Weighted Average
19,972	61	26.30% Pervious Area
55,980	98	73.70% Impervious Area

Tc (min)	Length (feet)	Slope (ft/ft)	Velocity (ft/sec)	Capacity (cfs)	Description
6.0					Direct Entry,

**Subcatchment PS-1B:**

Hydrograph

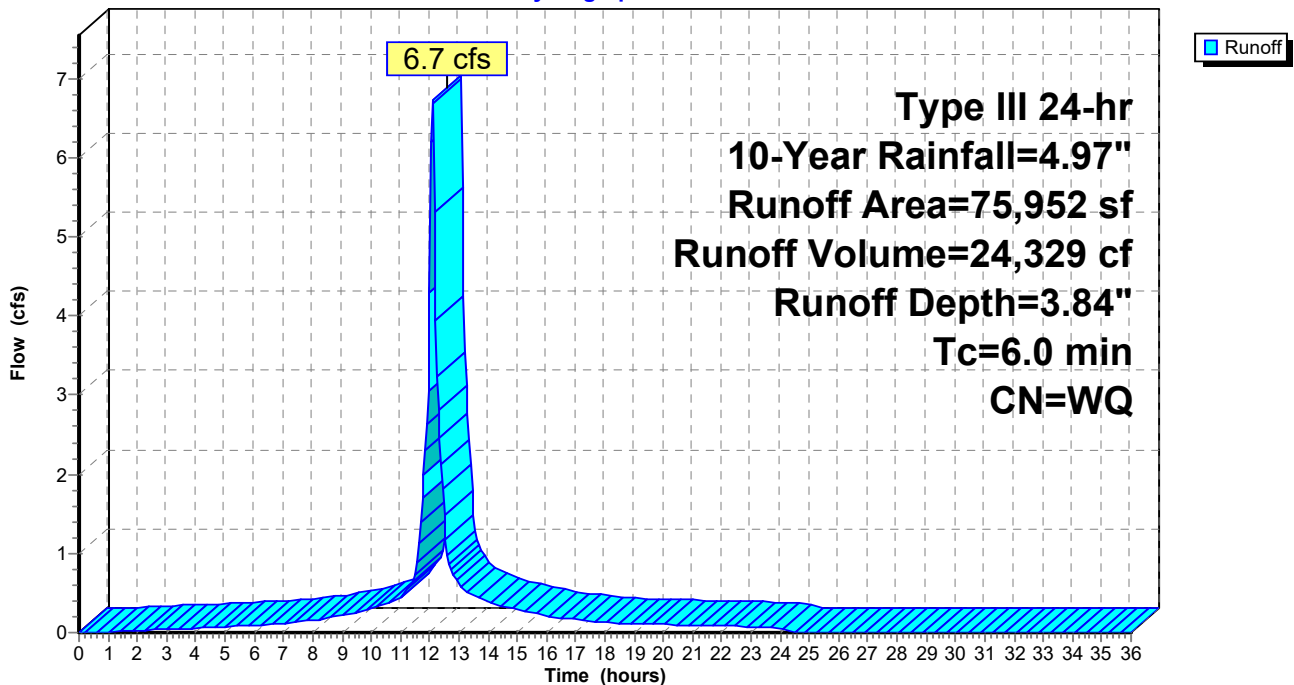

**250511 - POST (Tc-50)**

Prepared by R Levesque Associates

HydroCAD® 10.20-7a s/n 13073 © 2025 HydroCAD Software Solutions LLC

Type III 24-hr 10-Year Rainfall=4.97"

Printed 12/8/2025

Page 19

**Summary for Subcatchment PS-1C:**

Runoff = 0.4 cfs @ 12.20 hrs, Volume= 1,905 cf, Depth= 1.34"  
 Routed to Pond 2P :

Runoff by SCS TR-20 method, UH=SCS, Weighted-Q, Time Span= 0.00-36.00 hrs, dt= 0.05 hrs  
 Type III 24-hr 10-Year Rainfall=4.97"

Area (sf)	CN	Description
16,656	61	>75% Grass cover, Good, HSG B
364	55	Woods, Good, HSG B
17,021		Weighted Average
17,021	61	100.00% Pervious Area

Tc (min)	Length (feet)	Slope (ft/ft)	Velocity (ft/sec)	Capacity (cfs)	Description
11.0	50	0.0300	0.08		Sheet Flow, Grass: Bermuda n= 0.410 P2= 3.00"
1.4	290	0.0458	3.45		Shallow Concentrated Flow, Unpaved Kv= 16.1 fps
12.4	340	Total			

**Subcatchment PS-1C:**

Hydrograph

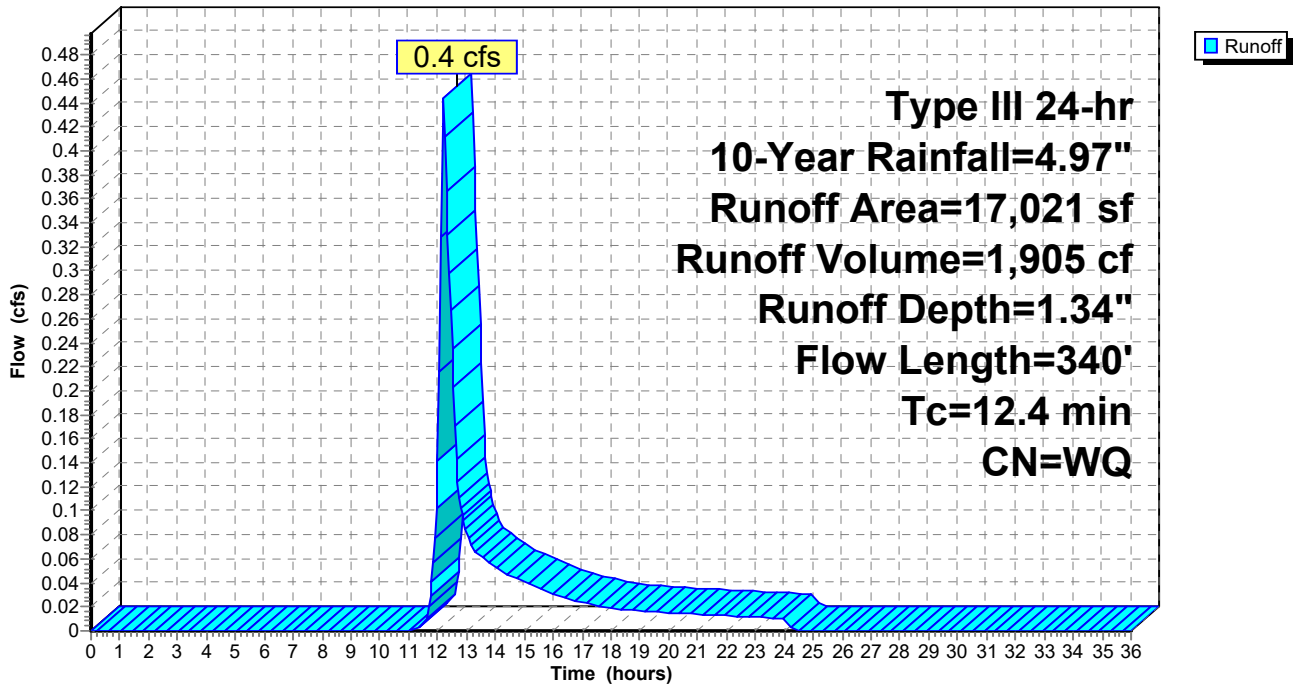

**250511 - POST (Tc-50)**

Prepared by R Levesque Associates

HydroCAD® 10.20-7a s/n 13073 © 2025 HydroCAD Software Solutions LLC

Type III 24-hr 10-Year Rainfall=4.97"

Printed 12/8/2025

Page 20

**Summary for Subcatchment PS-1D:**

Runoff = 2.6 cfs @ 12.11 hrs, Volume= 9,742 cf, Depth= 1.06"  
 Routed to Link DP-1 : WETLAND

Runoff by SCS TR-20 method, UH=SCS, Weighted-Q, Time Span= 0.00-36.00 hrs, dt= 0.05 hrs  
 Type III 24-hr 10-Year Rainfall=4.97"

Area (sf)	CN	Description
27,867	61	>75% Grass cover, Good, HSG B
0	98	Roofs, HSG B
82,121	55	Woods, Good, HSG B
109,989		Weighted Average
109,989	57	100.00% Pervious Area
0	98	0.00% Impervious Area

Tc (min)	Length (feet)	Slope (ft/ft)	Velocity (ft/sec)	Capacity (cfs)	Description
3.6	50	0.0650	0.23		<b>Sheet Flow,</b> Grass: Short n= 0.150 P2= 3.00"
1.7	321	0.0424	3.09		<b>Shallow Concentrated Flow,</b> Grassed Waterway Kv= 15.0 fps
5.3	371	Total, Increased to minimum Tc = 6.0 min			

**Subcatchment PS-1D:**

Hydrograph

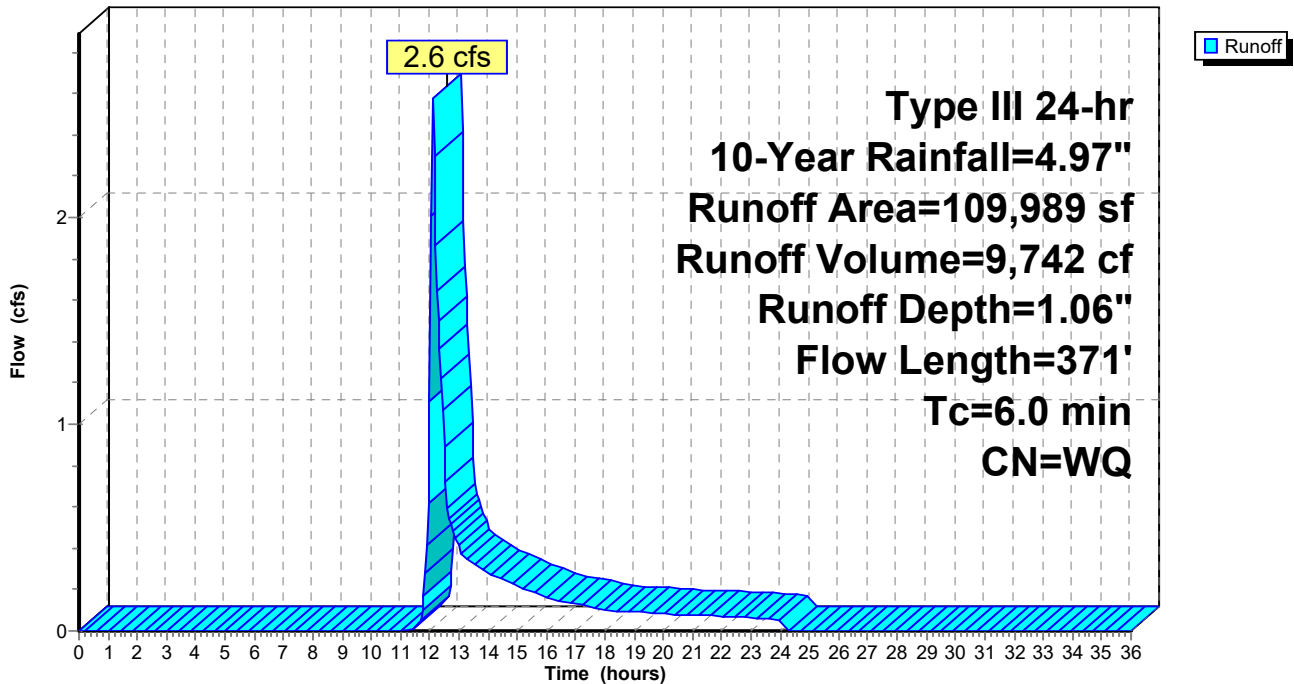

**Summary for Pond 1P:**

Inflow Area = 75,952 sf, 73.70% Impervious, Inflow Depth = 3.84" for 10-Year event  
 Inflow = 6.7 cfs @ 12.09 hrs, Volume= 24,329 cf  
 Outflow = 0.2 cfs @ 15.61 hrs, Volume= 23,153 cf, Atten= 96%, Lag= 211.5 min  
 Discarded = 0.2 cfs @ 9.05 hrs, Volume= 22,846 cf  
 Primary = 0.0 cfs @ 15.61 hrs, Volume= 307 cf  
 Routed to Link DP-1 : WETLAND

Routing by Stor-Ind method, Time Span= 0.00-36.00 hrs, dt= 0.05 hrs  
 Peak Elev= 234.94' @ 15.61 hrs Surf.Area= 8,967 sf Storage= 13,349 cf

Plug-Flow detention time= 520.8 min calculated for 23,153 cf (95% of inflow)  
 Center-of-Mass det. time= 492.3 min ( 1,252.0 - 759.6 )

Volume	Invert	Avail.Storage	Storage Description
#1A	232.83'	8,312 cf	<b>68.00'W x 131.87'L x 3.75'H Field A</b> 33,626 cf Overall - 12,845 cf Embedded = 20,781 cf x 40.0% Voids
#2A	233.33'	12,845 cf	<b>ADS_StormTech SC-800 +Cap x 252 Inside #1</b> Effective Size= 45.0"W x 33.0"H => 7.11 sf x 7.12'L = 50.6 cf Overall Size= 51.0"W x 33.0"H x 7.55'L with 0.43' Overlap 252 Chambers in 14 Rows Cap Storage= 3.4 cf x 2 x 14 rows = 95.8 cf
		21,157 cf	Total Available Storage

Storage Group A created with Chamber Wizard

Device	Routing	Invert	Outlet Devices
#1	Primary	231.83'	<b>12.0" Round Culvert</b> L= 104.0' RCP, groove end projecting, Ke= 0.200 Inlet / Outlet Invert= 231.83' / 229.23' S= 0.0250 '/ Cc= 0.900 n= 0.013 Corrugated PE, smooth interior, Flow Area= 0.79 sf
#2	Device 1	235.33'	<b>4.0' long Sharp-Crested Rectangular Weir</b> 2 End Contraction(s)
#3	Device 1	234.83'	<b>3.0" W x 3.0" H Vert. Orifice</b> C= 0.600 Limited to weir flow at low heads
#4	Discarded	232.83'	<b>1.020 in/hr Exfiltration over Surface area</b> Phase-In= 0.01'

**Discarded OutFlow** Max=0.2 cfs @ 9.05 hrs HW=232.87' (Free Discharge)

↳ **4=Exfiltration** (Exfiltration Controls 0.2 cfs)

**Primary OutFlow** Max=0.0 cfs @ 15.61 hrs HW=234.94' (Free Discharge)

↳ **1=Culvert** (Passes 0.0 cfs of 6.5 cfs potential flow)  
 ↳ **2=Sharp-Crested Rectangular Weir** ( Controls 0.0 cfs)  
 ↳ **3=Orifice** (Orifice Controls 0.0 cfs @ 1.07 fps)

**250511 - POST (Tc-50)**

Prepared by R Levesque Associates

HydroCAD® 10.20-7a s/n 13073 © 2025 HydroCAD Software Solutions LLC

Type III 24-hr 10-Year Rainfall=4.97"

Printed 12/8/2025

Page 22

**Pond 1P: - Chamber Wizard Field A**

**Chamber Model = ADS\_StormTech SC-800 +Cap (ADS StormTech® SC-800 with cap volume)**

Effective Size= 45.0"W x 33.0"H => 7.11 sf x 7.12'L = 50.6 cf

Overall Size= 51.0"W x 33.0"H x 7.55'L with 0.43' Overlap

Cap Storage= 3.4 cf x 2 x 14 rows = 95.8 cf

51.0" Wide + 6.0" Spacing = 57.0" C-C Row Spacing

18 Chambers/Row x 7.12' Long +0.88' Cap Length x 2 = 129.87' Row Length +12.0" End Stone x 2 = 131.87' Base Length

14 Rows x 51.0" Wide + 6.0" Spacing x 13 + 12.0" Side Stone x 2 = 68.00' Base Width

6.0" Stone Base + 33.0" Chamber Height + 6.0" Stone Cover = 3.75' Field Height

252 Chambers x 50.6 cf + 3.4 cf Cap Volume x 2 x 14 Rows = 12,845.0 cf Chamber Storage

33,626.0 cf Field - 12,845.0 cf Chambers = 20,781.0 cf Stone x 40.0% Voids = 8,312.4 cf Stone Storage

Chamber Storage + Stone Storage = 21,157.4 cf = 0.486 af

Overall Storage Efficiency = 62.9%

Overall System Size = 131.87' x 68.00' x 3.75'

252 Chambers

1,245.4 cy Field

769.7 cy Stone

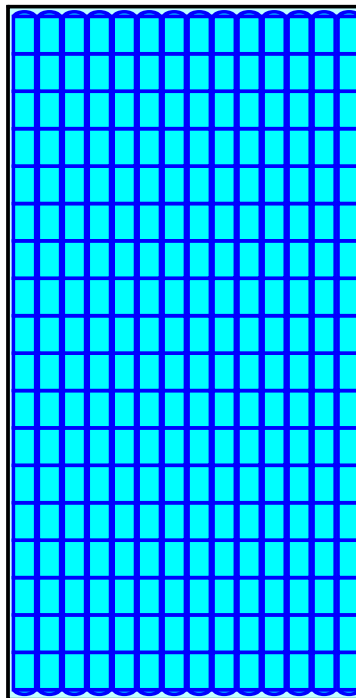

Pond 1P:

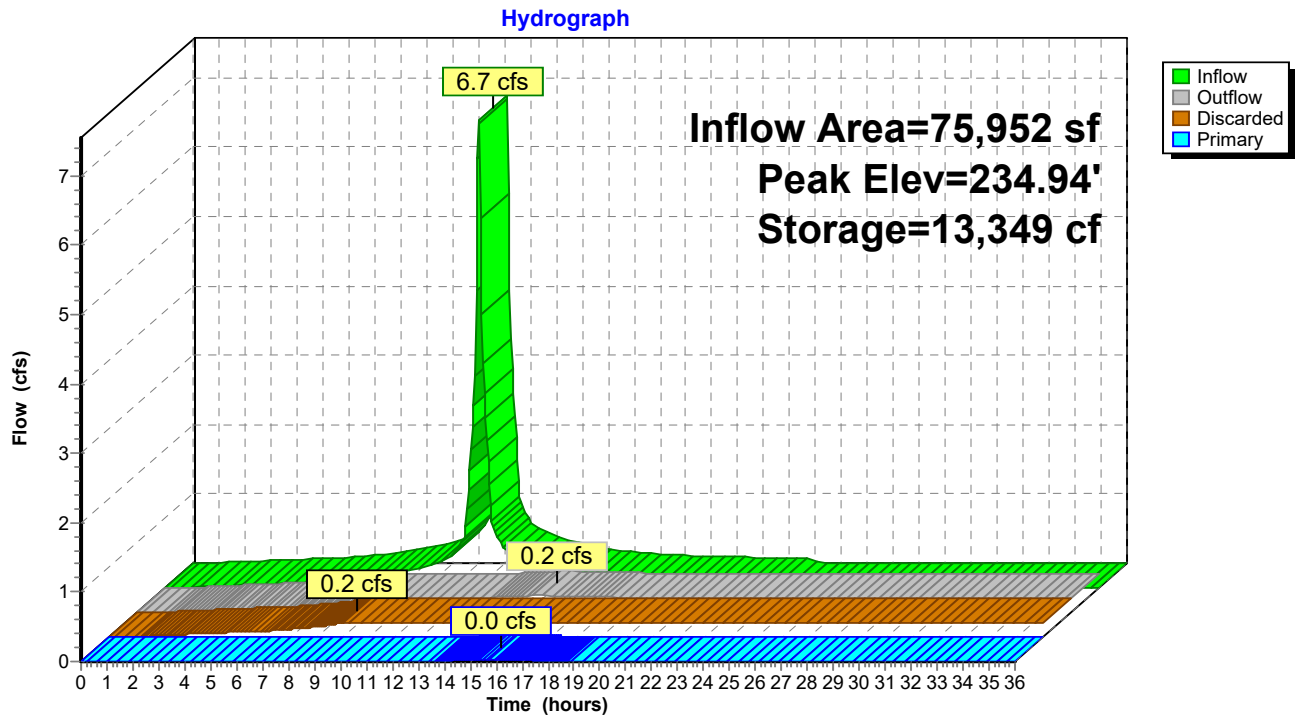

**Stage-Area-Storage for Pond 1P:**

Elevation (feet)	Surface (sq-ft)	Storage (cubic-feet)	Elevation (feet)	Surface (sq-ft)	Storage (cubic-feet)
232.83	8,967	0	235.48	8,967	16,615
232.88	8,967	179	235.53	8,967	16,891
232.93	8,967	359	235.58	8,967	17,160
232.98	8,967	538	235.63	8,967	17,423
233.03	8,967	717	235.68	8,967	17,678
233.08	8,967	897	235.73	8,967	17,923
233.13	8,967	1,076	235.78	8,967	18,157
233.18	8,967	1,255	235.83	8,967	18,379
233.23	8,967	1,435	235.88	8,967	18,590
233.28	8,967	1,614	235.93	8,967	18,793
233.33	8,967	1,793	235.98	8,967	18,990
233.38	8,967	2,176	236.03	8,967	19,180
233.43	8,967	2,557	236.08	8,967	19,364
233.48	8,967	2,938	236.13	8,967	19,543
233.53	8,967	3,317	236.18	8,967	19,723
233.58	8,967	3,695	236.23	8,967	19,902
233.63	8,967	4,072	236.28	8,967	20,081
233.68	8,967	4,448	236.33	8,967	20,261
233.73	8,967	4,822	236.38	8,967	20,440
233.78	8,967	5,195	236.43	8,967	20,619
233.83	8,967	5,567	236.48	8,967	20,799
233.88	8,967	5,937	236.53	8,967	20,978
233.93	8,967	6,306	236.58	8,967	21,157
233.98	8,967	6,673			
234.03	8,967	7,039			
234.08	8,967	7,403			
234.13	8,967	7,765			
234.18	8,967	8,125			
234.23	8,967	8,484			
234.28	8,967	8,841			
234.33	8,967	9,196			
234.38	8,967	9,549			
234.43	8,967	9,900			
234.48	8,967	10,248			
234.53	8,967	10,595			
234.58	8,967	10,939			
234.63	8,967	11,281			
234.68	8,967	11,620			
234.73	8,967	11,957			
234.78	8,967	12,291			
234.83	8,967	12,622			
234.88	8,967	12,950			
234.93	8,967	13,276			
234.98	8,967	13,598			
235.03	8,967	13,917			
235.08	8,967	14,233			
235.13	8,967	14,545			
235.18	8,967	14,854			
235.23	8,967	15,158			
235.28	8,967	15,459			
235.33	8,967	15,755			
235.38	8,967	16,047			
235.43	8,967	16,333			

**Summary for Pond 2P:**

Inflow Area = 17,021 sf, 0.00% Impervious, Inflow Depth = 1.34" for 10-Year event  
 Inflow = 0.4 cfs @ 12.20 hrs, Volume= 1,905 cf  
 Outflow = 0.1 cfs @ 14.11 hrs, Volume= 1,847 cf, Atten= 89%, Lag= 115.0 min  
 Primary = 0.1 cfs @ 14.11 hrs, Volume= 1,847 cf  
 Routed to Link DP-1 : WETLAND  
 Secondary = 0.0 cfs @ 0.00 hrs, Volume= 0 cf  
 Routed to Link DP-1 : WETLAND

Routing by Stor-Ind method, Time Span= 0.00-36.00 hrs, dt= 0.05 hrs  
 Peak Elev= 227.01' @ 14.11 hrs Surf.Area= 1,230 sf Storage= 947 cf

Plug-Flow detention time= 426.5 min calculated for 1,847 cf (97% of inflow)  
 Center-of-Mass det. time= 410.0 min ( 1,289.0 - 879.0 )

Volume	Invert	Avail.Storage	Storage Description			
#1	226.00'	2,507 cf	<b>Custom Stage Data (Irregular)</b> Listed below (Recalc)			
Elevation (feet)	Surf.Area (sq-ft)	Perim. (feet)	Inc.Store (cubic-feet)	Cum.Store (cubic-feet)	Wet.Area (sq-ft)	
226.00	668	110.0	0	0	668	
227.00	1,221	151.0	931	931	1,529	
228.00	1,960	196.0	1,576	2,507	2,784	

Device	Routing	Invert	Outlet Devices
#1	Primary	226.00'	<b>6.0" Round Culvert</b> L= 158.0' RCP, groove end projecting, Ke= 0.200 Inlet / Outlet Invert= 226.00' / 225.00' S= 0.0063 ' /' Cc= 0.900 n= 0.013 Corrugated PE, smooth interior, Flow Area= 0.20 sf
#2	Device 1	226.00'	<b>1.0" Vert. Orifice</b> C= 0.600 Limited to weir flow at low heads
#3	Device 1	227.00'	<b>4.0' long Sharp-Crested Rectangular Weir</b> 2 End Contraction(s)
#4	Device 1	227.50'	<b>48.0" x 48.0" Horiz. Gate</b> C= 0.600 Limited to weir flow at low heads
#5	Secondary	227.50'	<b>10.0' long x 10.0' breadth Broad-Crested Rectangular Weir</b> Head (feet) 0.20 0.40 0.60 0.80 1.00 1.20 1.40 1.60 Coef. (English) 2.49 2.56 2.70 2.69 2.68 2.69 2.67 2.64

**Primary OutFlow** Max=0.0 cfs @ 14.11 hrs HW=227.01' (Free Discharge)

- ↑ 1=Culvert (Passes 0.0 cfs of 0.5 cfs potential flow)
- ↑ 2=Orifice (Orifice Controls 0.0 cfs @ 4.75 fps)
- ↑ 3=Sharp-Crested Rectangular Weir (Weir Controls 0.0 cfs @ 0.38 fps)
- ↑ 4=Gate ( Controls 0.0 cfs)

**Secondary OutFlow** Max=0.0 cfs @ 0.00 hrs HW=226.00' (Free Discharge)

- ↑ 5=Broad-Crested Rectangular Weir ( Controls 0.0 cfs)

### Pond 2P:

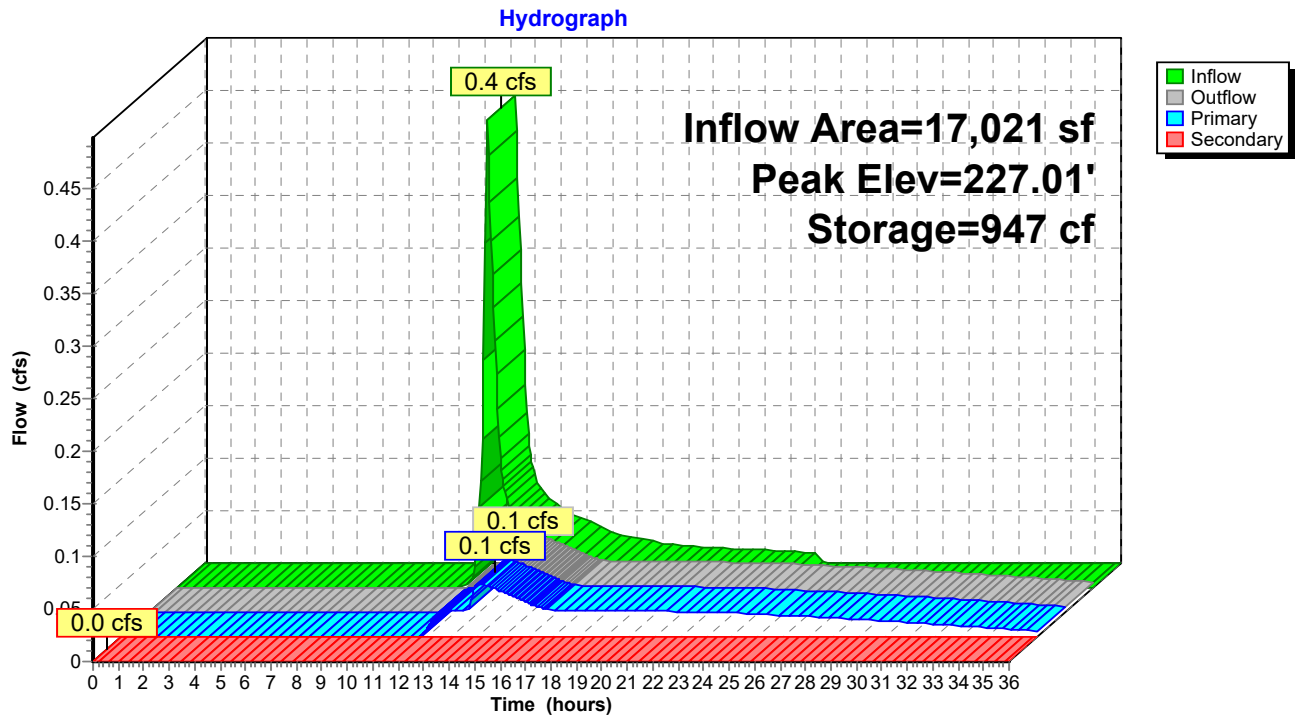

**Stage-Area-Storage for Pond 2P:**

Elevation (feet)	Surface (sq-ft)	Storage (cubic-feet)	Elevation (feet)	Surface (sq-ft)	Storage (cubic-feet)
226.00	668	0	227.06	1,260	1,005
226.02	677	13	227.08	1,274	1,030
226.04	687	27	227.10	1,287	1,056
226.06	697	41	227.12	1,300	1,082
226.08	706	55	227.14	1,314	1,108
226.10	716	69	227.16	1,328	1,135
226.12	726	84	227.18	1,341	1,161
226.14	735	98	227.20	1,355	1,188
226.16	745	113	227.22	1,369	1,215
226.18	755	128	227.24	1,382	1,243
226.20	765	143	227.26	1,396	1,271
226.22	775	159	227.28	1,410	1,299
226.24	786	174	227.30	1,424	1,327
226.26	796	190	227.32	1,439	1,356
226.28	806	206	227.34	1,453	1,385
226.30	817	222	227.36	1,467	1,414
226.32	827	239	227.38	1,481	1,443
226.34	837	255	227.40	1,496	1,473
226.36	848	272	227.42	1,510	1,503
226.38	859	289	227.44	1,525	1,534
226.40	869	307	227.46	1,539	1,564
226.42	880	324	227.48	1,554	1,595
226.44	891	342	227.50	1,569	1,626
226.46	902	360	227.52	1,584	1,658
226.48	913	378	227.54	1,598	1,690
226.50	924	396	227.56	1,613	1,722
226.52	935	415	227.58	1,628	1,754
226.54	946	434	227.60	1,644	1,787
226.56	957	453	227.62	1,659	1,820
226.58	969	472	227.64	1,674	1,853
226.60	980	491	227.66	1,689	1,887
226.62	991	511	227.68	1,705	1,921
226.64	1,003	531	227.70	1,720	1,955
226.66	1,014	551	227.72	1,736	1,990
226.68	1,026	572	227.74	1,751	2,025
226.70	1,038	592	227.76	1,767	2,060
226.72	1,049	613	227.78	1,782	2,095
226.74	1,061	634	227.80	1,798	2,131
226.76	1,073	656	227.82	1,814	2,167
226.78	1,085	677	227.84	1,830	2,204
226.80	1,097	699	227.86	1,846	2,240
226.82	1,109	721	227.88	1,862	2,277
226.84	1,121	743	227.90	1,878	2,315
226.86	1,134	766	227.92	1,894	2,353
226.88	1,146	789	227.94	1,911	2,391
226.90	1,158	812	227.96	1,927	2,429
226.92	1,171	835	227.98	1,944	2,468
226.94	1,183	859	228.00	<b>1,960</b>	<b>2,507</b>
226.96	1,196	882			
226.98	1,208	906			
227.00	1,221	931			
227.02	1,234	955			
227.04	1,247	980			

### Summary for Link DP-1: WETLAND

Inflow Area = 232,202 sf, 24.54% Impervious, Inflow Depth > 0.79" for 10-Year event  
Inflow = 3.3 cfs @ 12.12 hrs, Volume= 15,373 cf  
Primary = 3.3 cfs @ 12.12 hrs, Volume= 15,373 cf, Atten= 0%, Lag= 0.0 min

Primary outflow = Inflow, Time Span= 0.00-36.00 hrs, dt= 0.05 hrs

### Link DP-1: WETLAND

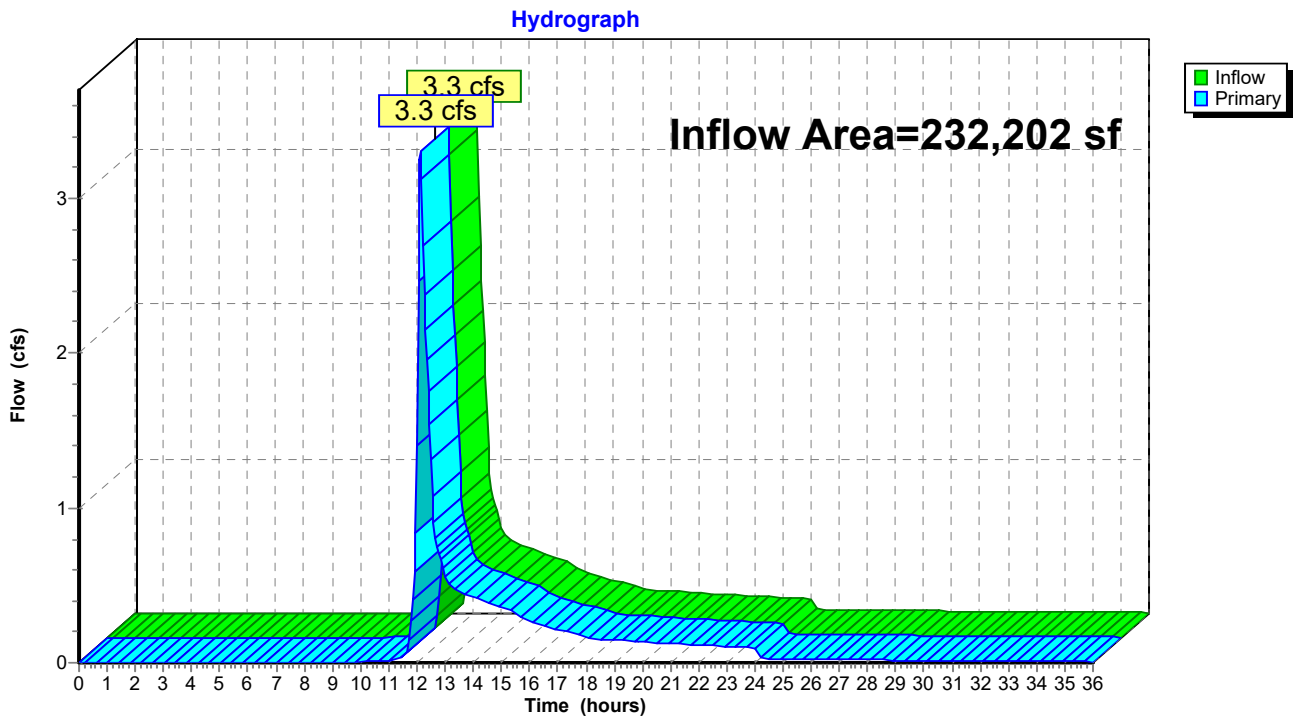

**250511 - POST (Tc-50)**

Type III 24-hr 100-Year Rainfall=7.96"

Prepared by R Levesque Associates

Printed 12/8/2025

HydroCAD® 10.20-7a s/n 13073 © 2025 HydroCAD Software Solutions LLC

Page 29

Time span=0.00-36.00 hrs, dt=0.05 hrs, 721 points  
Runoff by SCS TR-20 method, UH=SCS, Weighted-Q  
Reach routing by Stor-Ind+Trans method - Pond routing by Stor-Ind method

**Subcatchment PS-1A:** Runoff Area=29,240 sf 3.45% Impervious Runoff Depth=3.48"  
Flow Length=234' Tc=11.4 min CN=WQ Runoff=2.2 cfs 8,481 cf

**Subcatchment PS-1B:** Runoff Area=75,952 sf 73.70% Impervious Runoff Depth=6.59"  
Tc=6.0 min CN=WQ Runoff=11.6 cfs 41,697 cf

**Subcatchment PS-1C:** Runoff Area=17,021 sf 0.00% Impervious Runoff Depth=3.40"  
Flow Length=340' Tc=12.4 min CN=WQ Runoff=1.2 cfs 4,823 cf

**Subcatchment PS-1D:** Runoff Area=109,989 sf 0.00% Impervious Runoff Depth=2.92"  
Flow Length=371' Tc=6.0 min CN=WQ Runoff=8.2 cfs 26,795 cf

**Pond 1P:** Peak Elev=235.72' Storage=17,878 cf Inflow=11.6 cfs 41,697 cf  
Discarded=0.2 cfs 24,357 cf Primary=3.4 cfs 13,867 cf Outflow=3.6 cfs 38,224 cf

**Pond 2P:** Peak Elev=227.36' Storage=1,414 cf Inflow=1.2 cfs 4,823 cf  
Primary=0.6 cfs 4,692 cf Secondary=0.0 cfs 0 cf Outflow=0.6 cfs 4,692 cf

**Link DP-1: WETLAND** Inflow=10.2 cfs 53,835 cf  
Primary=10.2 cfs 53,835 cf

**Total Runoff Area = 232,202 sf Runoff Volume = 81,796 cf Average Runoff Depth = 4.23"**  
**75.46% Pervious = 175,212 sf 24.54% Impervious = 56,990 sf**

**250511 - POST (Tc-50)**

Prepared by R Levesque Associates  
 HydroCAD® 10.20-7a s/n 13073 © 2025 HydroCAD Software Solutions LLC

Type III 24-hr 100-Year Rainfall=7.96"

Printed 12/8/2025

Page 30

**Summary for Subcatchment PS-1A:**

Runoff = 2.2 cfs @ 12.17 hrs, Volume= 8,481 cf, Depth= 3.48"  
 Routed to Link DP-1 : WETLAND

Runoff by SCS TR-20 method, UH=SCS, Weighted-Q, Time Span= 0.00-36.00 hrs, dt= 0.05 hrs  
 Type III 24-hr 100-Year Rainfall=7.96"

Area (sf)	CN	Description
16,864	61	>75% Grass cover, Good, HSG B
234	74	>75% Grass cover, Good, HSG C
1,009	98	Roofs, HSG B
8,399	55	Woods, Good, HSG B
2,734	70	Woods, Good, HSG C

29,240		Weighted Average
28,231	60	96.55% Pervious Area
1,009	98	3.45% Impervious Area

Tc (min)	Length (feet)	Slope (ft/ft)	Velocity (ft/sec)	Capacity (cfs)	Description
7.3	50	0.0800	0.11		<b>Sheet Flow,</b> Woods: Light underbrush n= 0.400 P2= 3.00"
4.1	184	0.0224	0.75		<b>Shallow Concentrated Flow,</b> Woodland Kv= 5.0 fps
11.4	234	Total			

**Subcatchment PS-1A:**

Hydrograph

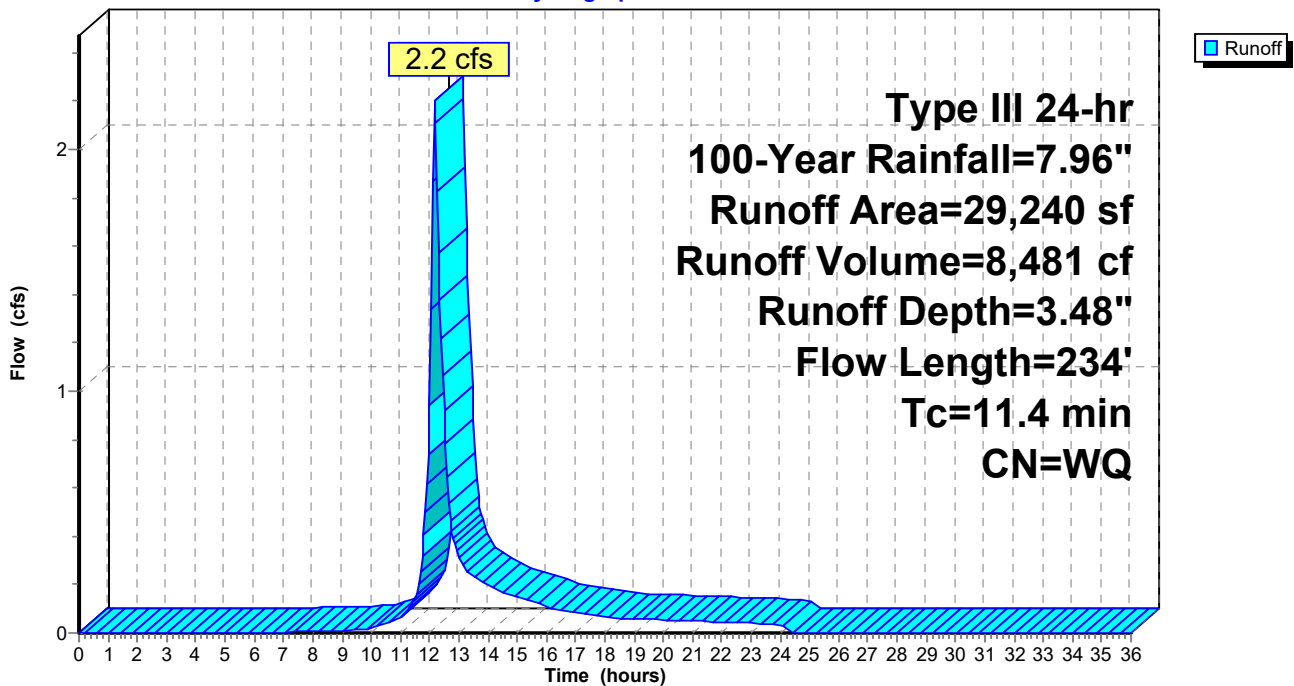

**250511 - POST (Tc-50)**

Prepared by R Levesque Associates

HydroCAD® 10.20-7a s/n 13073 © 2025 HydroCAD Software Solutions LLC

Type III 24-hr 100-Year Rainfall=7.96"

Printed 12/8/2025

Page 31

**Summary for Subcatchment PS-1B:**

Runoff = 11.6 cfs @ 12.09 hrs, Volume= 41,697 cf, Depth= 6.59"  
 Routed to Pond 1P :

Runoff by SCS TR-20 method, UH=SCS, Weighted-Q, Time Span= 0.00-36.00 hrs, dt= 0.05 hrs  
 Type III 24-hr 100-Year Rainfall=7.96"

Area (sf)	CN	Description
19,972	61	>75% Grass cover, Good, HSG B
27,201	98	Paved parking, HSG B
28,779	98	Roofs, HSG B
75,952		Weighted Average
19,972	61	26.30% Pervious Area
55,980	98	73.70% Impervious Area

Tc (min)	Length (feet)	Slope (ft/ft)	Velocity (ft/sec)	Capacity (cfs)	Description
6.0					Direct Entry,

**Subcatchment PS-1B:**

Hydrograph

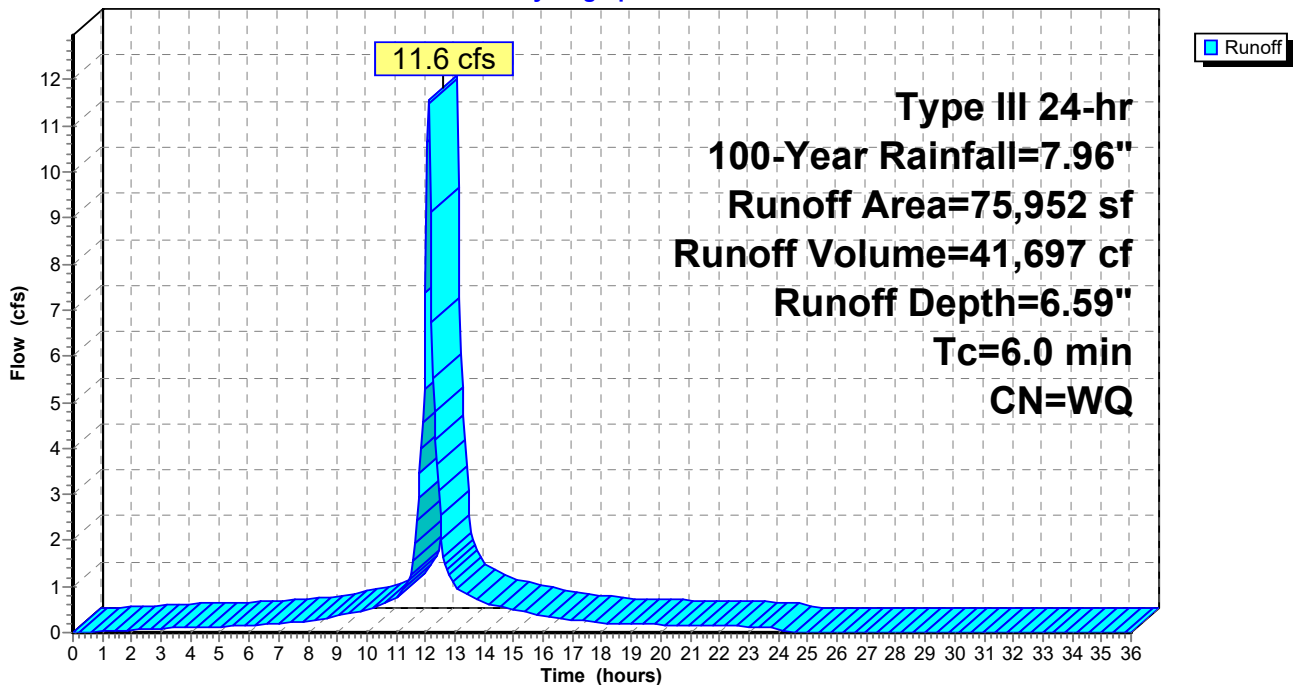

**250511 - POST (Tc-50)**

Prepared by R Levesque Associates

HydroCAD® 10.20-7a s/n 13073 © 2025 HydroCAD Software Solutions LLC

Type III 24-hr 100-Year Rainfall=7.96"

Printed 12/8/2025

Page 32

**Summary for Subcatchment PS-1C:**

Runoff = 1.2 cfs @ 12.18 hrs, Volume= 4,823 cf, Depth= 3.40"  
 Routed to Pond 2P :

Runoff by SCS TR-20 method, UH=SCS, Weighted-Q, Time Span= 0.00-36.00 hrs, dt= 0.05 hrs  
 Type III 24-hr 100-Year Rainfall=7.96"

Area (sf)	CN	Description
16,656	61	>75% Grass cover, Good, HSG B
364	55	Woods, Good, HSG B
17,021		Weighted Average
17,021	61	100.00% Pervious Area

Tc (min)	Length (feet)	Slope (ft/ft)	Velocity (ft/sec)	Capacity (cfs)	Description
11.0	50	0.0300	0.08		<b>Sheet Flow,</b> Grass: Bermuda n= 0.410 P2= 3.00"
1.4	290	0.0458	3.45		<b>Shallow Concentrated Flow,</b> Unpaved Kv= 16.1 fps
12.4	340	Total			

**Subcatchment PS-1C:**

Hydrograph

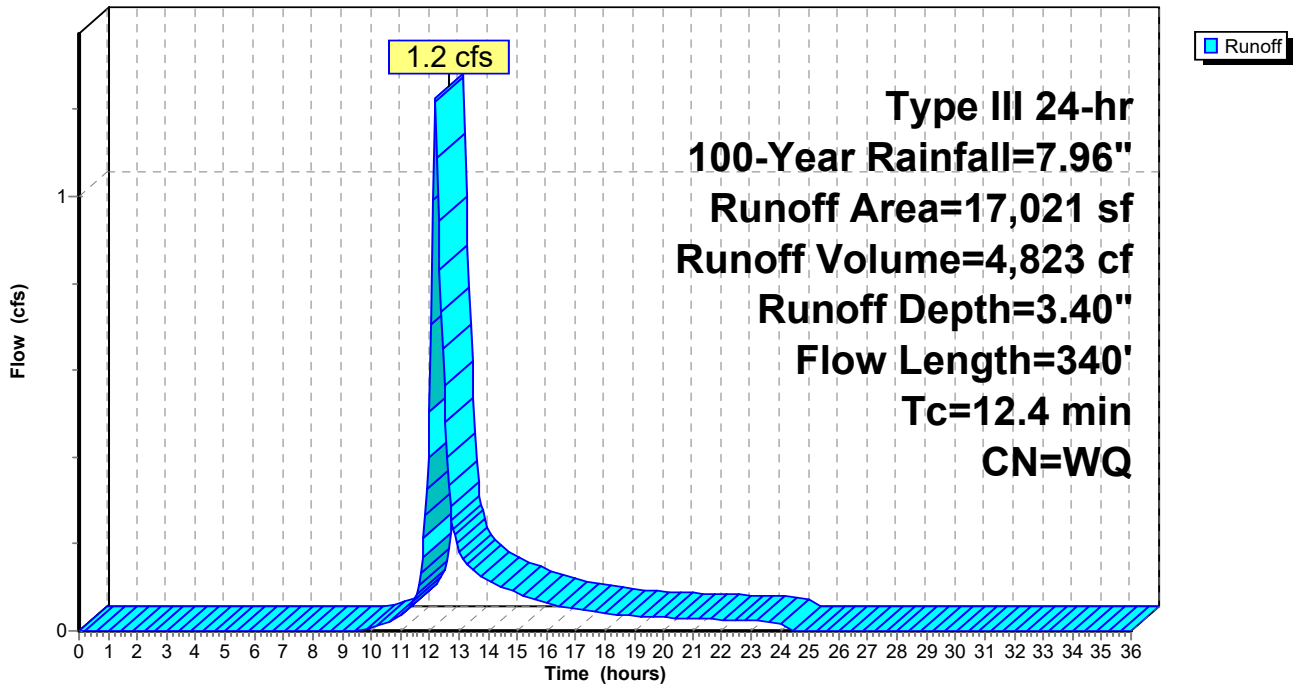

**250511 - POST (Tc-50)**

Prepared by R Levesque Associates

HydroCAD® 10.20-7a s/n 13073 © 2025 HydroCAD Software Solutions LLC

Type III 24-hr 100-Year Rainfall=7.96"

Printed 12/8/2025

Page 33

**Summary for Subcatchment PS-1D:**

Runoff = 8.2 cfs @ 12.10 hrs, Volume= 26,795 cf, Depth= 2.92"  
 Routed to Link DP-1 : WETLAND

Runoff by SCS TR-20 method, UH=SCS, Weighted-Q, Time Span= 0.00-36.00 hrs, dt= 0.05 hrs  
 Type III 24-hr 100-Year Rainfall=7.96"

Area (sf)	CN	Description
27,867	61	>75% Grass cover, Good, HSG B
0	98	Roofs, HSG B
82,121	55	Woods, Good, HSG B
109,989		Weighted Average
109,989	57	100.00% Pervious Area
0	98	0.00% Impervious Area

Tc (min)	Length (feet)	Slope (ft/ft)	Velocity (ft/sec)	Capacity (cfs)	Description
3.6	50	0.0650	0.23		<b>Sheet Flow,</b> Grass: Short n= 0.150 P2= 3.00"
1.7	321	0.0424	3.09		<b>Shallow Concentrated Flow,</b> Grassed Waterway Kv= 15.0 fps
5.3	371	Total, Increased to minimum Tc = 6.0 min			

**Subcatchment PS-1D:**

Hydrograph

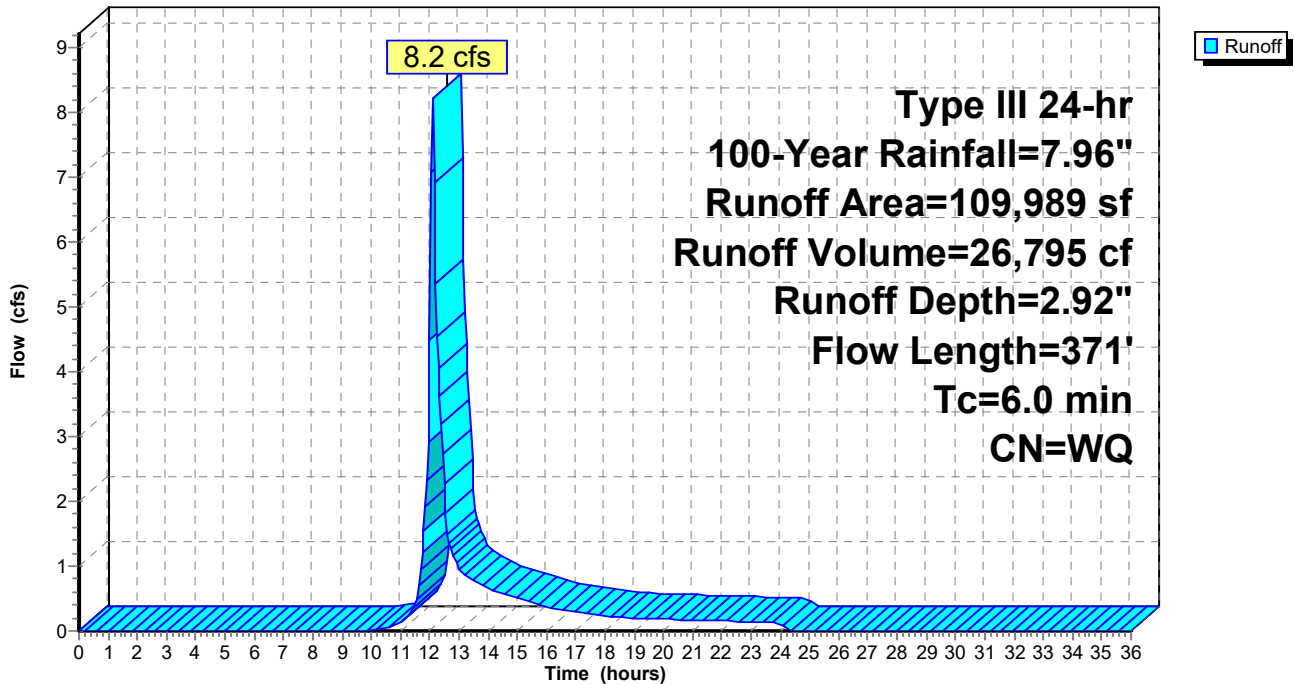

**250511 - POST (Tc-50)**

Type III 24-hr 100-Year Rainfall=7.96"

Prepared by R Levesque Associates

Printed 12/8/2025

HydroCAD® 10.20-7a s/n 13073 © 2025 HydroCAD Software Solutions LLC

Page 34

**Summary for Pond 1P:**

Inflow Area = 75,952 sf, 73.70% Impervious, Inflow Depth = 6.59" for 100-Year event  
 Inflow = 11.6 cfs @ 12.09 hrs, Volume= 41,697 cf  
 Outflow = 3.6 cfs @ 12.41 hrs, Volume= 38,224 cf, Atten= 69%, Lag= 19.2 min  
 Discarded = 0.2 cfs @ 7.40 hrs, Volume= 24,357 cf  
 Primary = 3.4 cfs @ 12.41 hrs, Volume= 13,867 cf  
 Routed to Link DP-1 : WETLAND

Routing by Stor-Ind method, Time Span= 0.00-36.00 hrs, dt= 0.05 hrs  
 Peak Elev= 235.72' @ 12.41 hrs Surf.Area= 8,967 sf Storage= 17,878 cf

Plug-Flow detention time= 360.6 min calculated for 38,171 cf (92% of inflow)  
 Center-of-Mass det. time= 317.2 min ( 1,072.5 - 755.3 )

Volume	Invert	Avail.Storage	Storage Description
#1A	232.83'	8,312 cf	<b>68.00'W x 131.87'L x 3.75'H Field A</b> 33,626 cf Overall - 12,845 cf Embedded = 20,781 cf x 40.0% Voids
#2A	233.33'	12,845 cf	<b>ADS_StormTech SC-800 +Cap x 252 Inside #1</b> Effective Size= 45.0"W x 33.0"H => 7.11 sf x 7.12'L = 50.6 cf Overall Size= 51.0"W x 33.0"H x 7.55'L with 0.43' Overlap 252 Chambers in 14 Rows Cap Storage= 3.4 cf x 2 x 14 rows = 95.8 cf
		21,157 cf	Total Available Storage

Storage Group A created with Chamber Wizard

Device	Routing	Invert	Outlet Devices
#1	Primary	231.83'	<b>12.0" Round Culvert</b> L= 104.0' RCP, groove end projecting, Ke= 0.200 Inlet / Outlet Invert= 231.83' / 229.23' S= 0.0250 '/ Cc= 0.900 n= 0.013 Corrugated PE, smooth interior, Flow Area= 0.79 sf
#2	Device 1	235.33'	<b>4.0' long Sharp-Crested Rectangular Weir</b> 2 End Contraction(s)
#3	Device 1	234.83'	<b>3.0" W x 3.0" H Vert. Orifice</b> C= 0.600 Limited to weir flow at low heads
#4	Discarded	232.83'	<b>1.020 in/hr Exfiltration over Surface area</b> Phase-In= 0.01'

**Discarded OutFlow** Max=0.2 cfs @ 7.40 hrs HW=232.87' (Free Discharge)

↳ **4=Exfiltration** (Exfiltration Controls 0.2 cfs)

**Primary OutFlow** Max=3.4 cfs @ 12.41 hrs HW=235.72' (Free Discharge)

↳ **1=Culvert** (Passes 3.4 cfs of 7.0 cfs potential flow)

↳ **2=Sharp-Crested Rectangular Weir** (Weir Controls 3.1 cfs @ 2.04 fps)

↳ **3=Orifice** (Orifice Controls 0.3 cfs @ 4.20 fps)

**Pond 1P: - Chamber Wizard Field A**

**Chamber Model = ADS\_StormTech SC-800 +Cap (ADS StormTech® SC-800 with cap volume)**

Effective Size= 45.0"W x 33.0"H => 7.11 sf x 7.12'L = 50.6 cf

Overall Size= 51.0"W x 33.0"H x 7.55'L with 0.43' Overlap

Cap Storage= 3.4 cf x 2 x 14 rows = 95.8 cf

51.0" Wide + 6.0" Spacing = 57.0" C-C Row Spacing

18 Chambers/Row x 7.12' Long +0.88' Cap Length x 2 = 129.87' Row Length +12.0" End Stone x 2 = 131.87' Base Length

14 Rows x 51.0" Wide + 6.0" Spacing x 13 + 12.0" Side Stone x 2 = 68.00' Base Width

6.0" Stone Base + 33.0" Chamber Height + 6.0" Stone Cover = 3.75' Field Height

252 Chambers x 50.6 cf + 3.4 cf Cap Volume x 2 x 14 Rows = 12,845.0 cf Chamber Storage

33,626.0 cf Field - 12,845.0 cf Chambers = 20,781.0 cf Stone x 40.0% Voids = 8,312.4 cf Stone Storage

Chamber Storage + Stone Storage = 21,157.4 cf = 0.486 af

Overall Storage Efficiency = 62.9%

Overall System Size = 131.87' x 68.00' x 3.75'

252 Chambers

1,245.4 cy Field

769.7 cy Stone

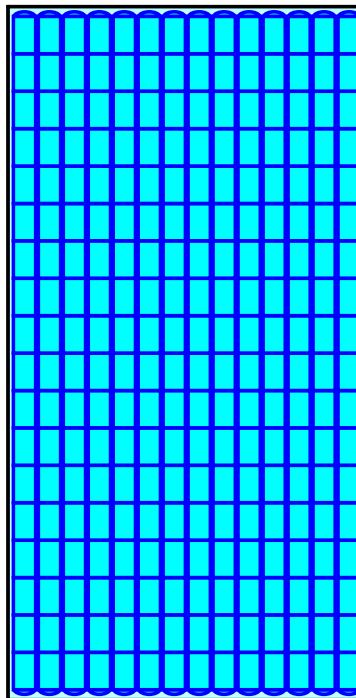

Pond 1P:

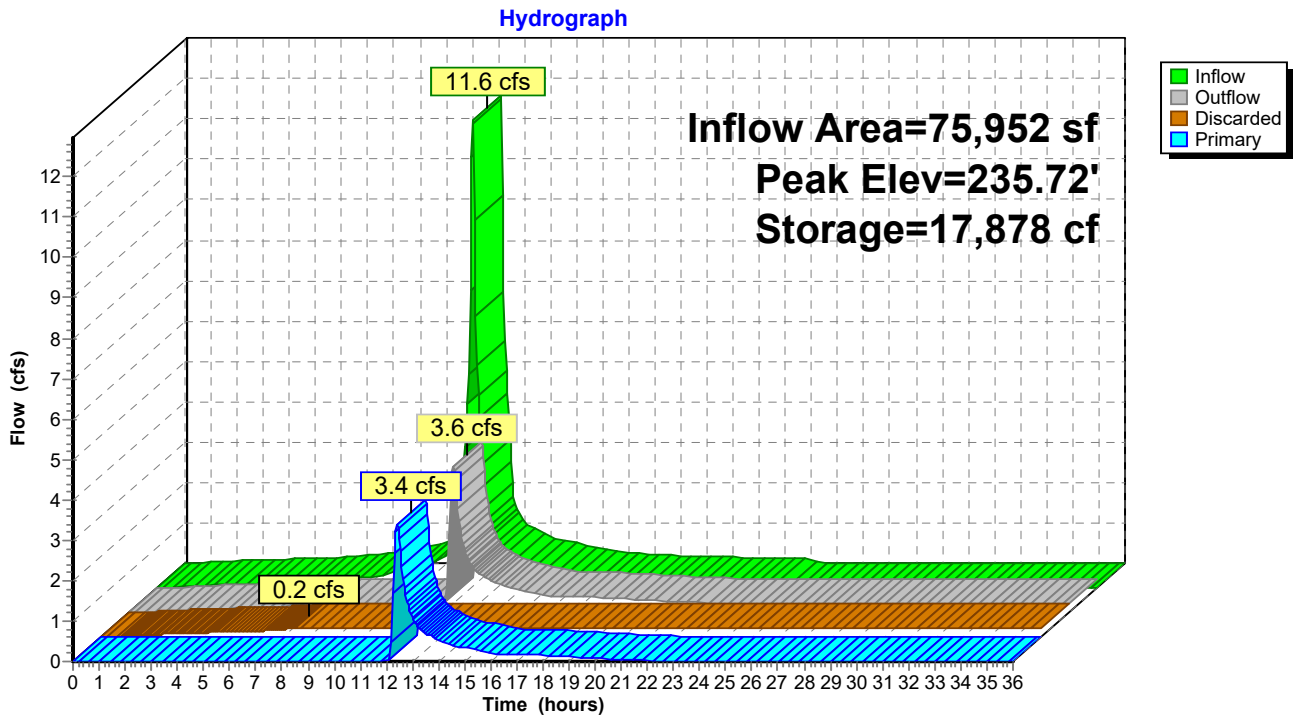

**Stage-Area-Storage for Pond 1P:**

Elevation (feet)	Surface (sq-ft)	Storage (cubic-feet)	Elevation (feet)	Surface (sq-ft)	Storage (cubic-feet)
232.83	<b>8,967</b>	0	235.48	8,967	16,615
232.88	8,967	179	235.53	8,967	16,891
232.93	8,967	359	235.58	8,967	17,160
232.98	8,967	538	235.63	8,967	17,423
233.03	8,967	717	235.68	8,967	17,678
233.08	8,967	897	235.73	8,967	17,923
233.13	8,967	1,076	235.78	8,967	18,157
233.18	8,967	1,255	235.83	8,967	18,379
233.23	8,967	1,435	235.88	8,967	18,590
233.28	8,967	1,614	235.93	8,967	18,793
233.33	8,967	1,793	235.98	8,967	18,990
233.38	8,967	2,176	236.03	8,967	19,180
233.43	8,967	2,557	236.08	8,967	19,364
233.48	8,967	2,938	236.13	8,967	19,543
233.53	8,967	3,317	236.18	8,967	19,723
233.58	8,967	3,695	236.23	8,967	19,902
233.63	8,967	4,072	236.28	8,967	20,081
233.68	8,967	4,448	236.33	8,967	20,261
233.73	8,967	4,822	236.38	8,967	20,440
233.78	8,967	5,195	236.43	8,967	20,619
233.83	8,967	5,567	236.48	8,967	20,799
233.88	8,967	5,937	236.53	8,967	20,978
233.93	8,967	6,306	236.58	8,967	<b>21,157</b>
233.98	8,967	6,673			
234.03	8,967	7,039			
234.08	8,967	7,403			
234.13	8,967	7,765			
234.18	8,967	8,125			
234.23	8,967	8,484			
234.28	8,967	8,841			
234.33	8,967	9,196			
234.38	8,967	9,549			
234.43	8,967	9,900			
234.48	8,967	10,248			
234.53	8,967	10,595			
234.58	8,967	10,939			
234.63	8,967	11,281			
234.68	8,967	11,620			
234.73	8,967	11,957			
234.78	8,967	12,291			
234.83	8,967	12,622			
234.88	8,967	12,950			
234.93	8,967	13,276			
234.98	8,967	13,598			
235.03	8,967	13,917			
235.08	8,967	14,233			
235.13	8,967	14,545			
235.18	8,967	14,854			
235.23	8,967	15,158			
235.28	8,967	15,459			
235.33	8,967	15,755			
235.38	8,967	16,047			
235.43	8,967	16,333			

**Summary for Pond 2P:**

Inflow Area = 17,021 sf, 0.00% Impervious, Inflow Depth = 3.40" for 100-Year event  
 Inflow = 1.2 cfs @ 12.18 hrs, Volume= 4,823 cf  
 Outflow = 0.6 cfs @ 12.49 hrs, Volume= 4,692 cf, Atten= 53%, Lag= 18.6 min  
 Primary = 0.6 cfs @ 12.49 hrs, Volume= 4,692 cf  
 Routed to Link DP-1 : WETLAND  
 Secondary = 0.0 cfs @ 0.00 hrs, Volume= 0 cf  
 Routed to Link DP-1 : WETLAND

Routing by Stor-Ind method, Time Span= 0.00-36.00 hrs, dt= 0.05 hrs  
 Peak Elev= 227.36' @ 12.49 hrs Surf.Area= 1,467 sf Storage= 1,414 cf

Plug-Flow detention time= 201.2 min calculated for 4,685 cf (97% of inflow)  
 Center-of-Mass det. time= 186.7 min ( 1,037.1 - 850.4 )

Volume	Invert	Avail.Storage	Storage Description		
#1	226.00'	2,507 cf	<b>Custom Stage Data (Irregular)</b> Listed below (Recalc)		
Elevation (feet)	Surf.Area (sq-ft)	Perim. (feet)	Inc.Store (cubic-feet)	Cum.Store (cubic-feet)	Wet.Area (sq-ft)
226.00	668	110.0	0	0	668
227.00	1,221	151.0	931	931	1,529
228.00	1,960	196.0	1,576	2,507	2,784

Device	Routing	Invert	Outlet Devices
#1	Primary	226.00'	<b>6.0" Round Culvert</b> L= 158.0' RCP, groove end projecting, Ke= 0.200 Inlet / Outlet Invert= 226.00' / 225.00' S= 0.0063 ' / Cc= 0.900 n= 0.013 Corrugated PE, smooth interior, Flow Area= 0.20 sf
#2	Device 1	226.00'	<b>1.0" Vert. Orifice</b> C= 0.600 Limited to weir flow at low heads
#3	Device 1	227.00'	<b>4.0' long Sharp-Crested Rectangular Weir</b> 2 End Contraction(s)
#4	Device 1	227.50'	<b>48.0" x 48.0" Horiz. Gate</b> C= 0.600 Limited to weir flow at low heads
#5	Secondary	227.50'	<b>10.0' long x 10.0' breadth Broad-Crested Rectangular Weir</b> Head (feet) 0.20 0.40 0.60 0.80 1.00 1.20 1.40 1.60 Coef. (English) 2.49 2.56 2.70 2.69 2.68 2.69 2.67 2.64

**Primary OutFlow** Max=0.6 cfs @ 12.49 hrs HW=227.36' (Free Discharge)

- ↑ 1=Culvert (Barrel Controls 0.6 cfs @ 2.96 fps)
- ↑ 2=Orifice (Passes < 0.0 cfs potential flow)
- ↑ 3=Sharp-Crested Rectangular Weir (Passes < 2.8 cfs potential flow)
- ↑ 4=Gate ( Controls 0.0 cfs)

**Secondary OutFlow** Max=0.0 cfs @ 0.00 hrs HW=226.00' (Free Discharge)

- ↑ 5=Broad-Crested Rectangular Weir ( Controls 0.0 cfs)

### Pond 2P:

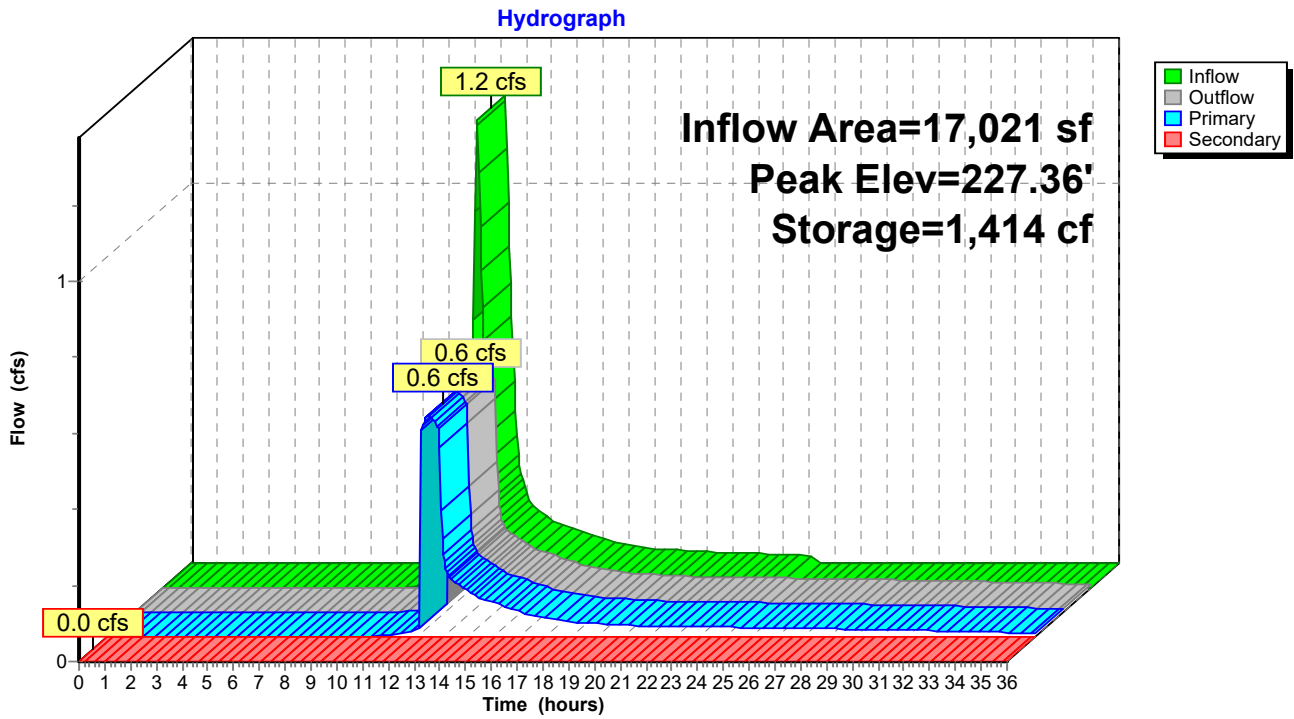

**Stage-Area-Storage for Pond 2P:**

Elevation (feet)	Surface (sq-ft)	Storage (cubic-feet)	Elevation (feet)	Surface (sq-ft)	Storage (cubic-feet)
226.00	668	0	227.06	1,260	1,005
226.02	677	13	227.08	1,274	1,030
226.04	687	27	227.10	1,287	1,056
226.06	697	41	227.12	1,300	1,082
226.08	706	55	227.14	1,314	1,108
226.10	716	69	227.16	1,328	1,135
226.12	726	84	227.18	1,341	1,161
226.14	735	98	227.20	1,355	1,188
226.16	745	113	227.22	1,369	1,215
226.18	755	128	227.24	1,382	1,243
226.20	765	143	227.26	1,396	1,271
226.22	775	159	227.28	1,410	1,299
226.24	786	174	227.30	1,424	1,327
226.26	796	190	227.32	1,439	1,356
226.28	806	206	227.34	1,453	1,385
226.30	817	222	227.36	1,467	1,414
226.32	827	239	227.38	1,481	1,443
226.34	837	255	227.40	1,496	1,473
226.36	848	272	227.42	1,510	1,503
226.38	859	289	227.44	1,525	1,534
226.40	869	307	227.46	1,539	1,564
226.42	880	324	227.48	1,554	1,595
226.44	891	342	227.50	1,569	1,626
226.46	902	360	227.52	1,584	1,658
226.48	913	378	227.54	1,598	1,690
226.50	924	396	227.56	1,613	1,722
226.52	935	415	227.58	1,628	1,754
226.54	946	434	227.60	1,644	1,787
226.56	957	453	227.62	1,659	1,820
226.58	969	472	227.64	1,674	1,853
226.60	980	491	227.66	1,689	1,887
226.62	991	511	227.68	1,705	1,921
226.64	1,003	531	227.70	1,720	1,955
226.66	1,014	551	227.72	1,736	1,990
226.68	1,026	572	227.74	1,751	2,025
226.70	1,038	592	227.76	1,767	2,060
226.72	1,049	613	227.78	1,782	2,095
226.74	1,061	634	227.80	1,798	2,131
226.76	1,073	656	227.82	1,814	2,167
226.78	1,085	677	227.84	1,830	2,204
226.80	1,097	699	227.86	1,846	2,240
226.82	1,109	721	227.88	1,862	2,277
226.84	1,121	743	227.90	1,878	2,315
226.86	1,134	766	227.92	1,894	2,353
226.88	1,146	789	227.94	1,911	2,391
226.90	1,158	812	227.96	1,927	2,429
226.92	1,171	835	227.98	1,944	2,468
226.94	1,183	859	228.00	<b>1,960</b>	<b>2,507</b>
226.96	1,196	882			
226.98	1,208	906			
227.00	1,221	931			
227.02	1,234	955			
227.04	1,247	980			

### Summary for Link DP-1: WETLAND

Inflow Area = 232,202 sf, 24.54% Impervious, Inflow Depth > 2.78" for 100-Year event  
Inflow = 10.2 cfs @ 12.11 hrs, Volume= 53,835 cf  
Primary = 10.2 cfs @ 12.11 hrs, Volume= 53,835 cf, Atten= 0%, Lag= 0.0 min

Primary outflow = Inflow, Time Span= 0.00-36.00 hrs, dt= 0.05 hrs

### Link DP-1: WETLAND

Hydrograph

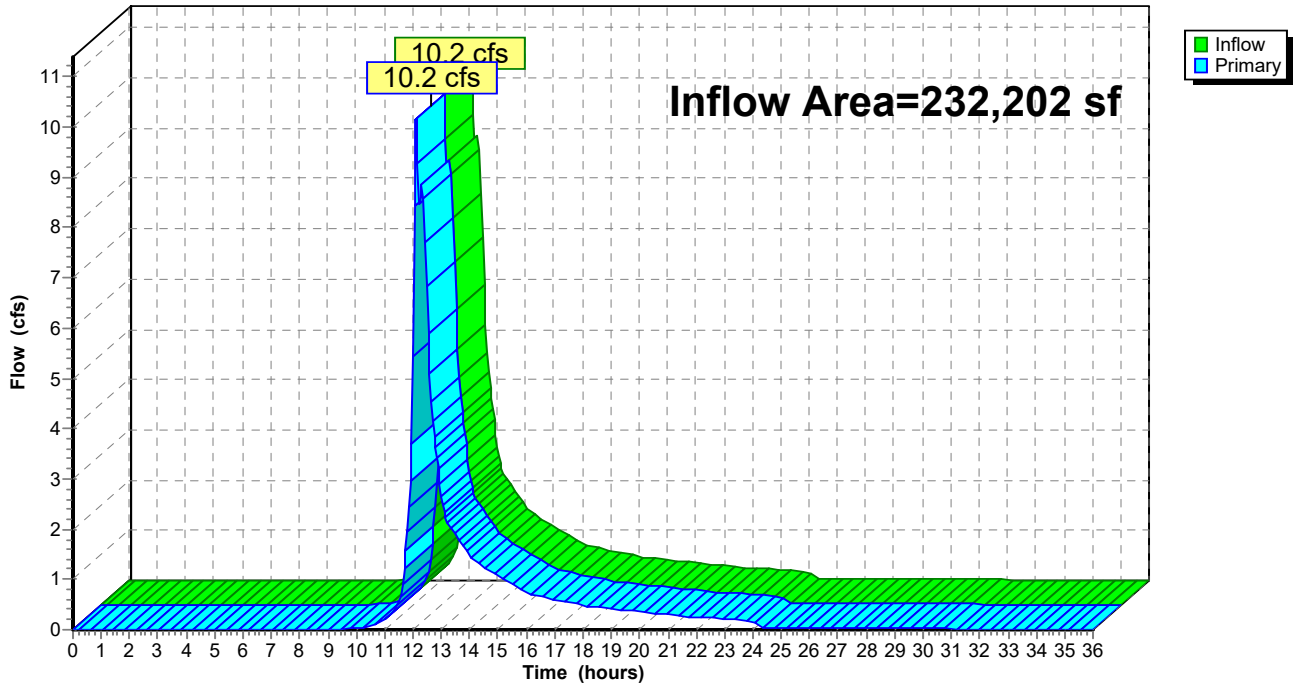



## Appendix D: Hydraulic Analysis



# Hydraflow Storm Sewers Extension for Autodesk® Civil 3D® Plan

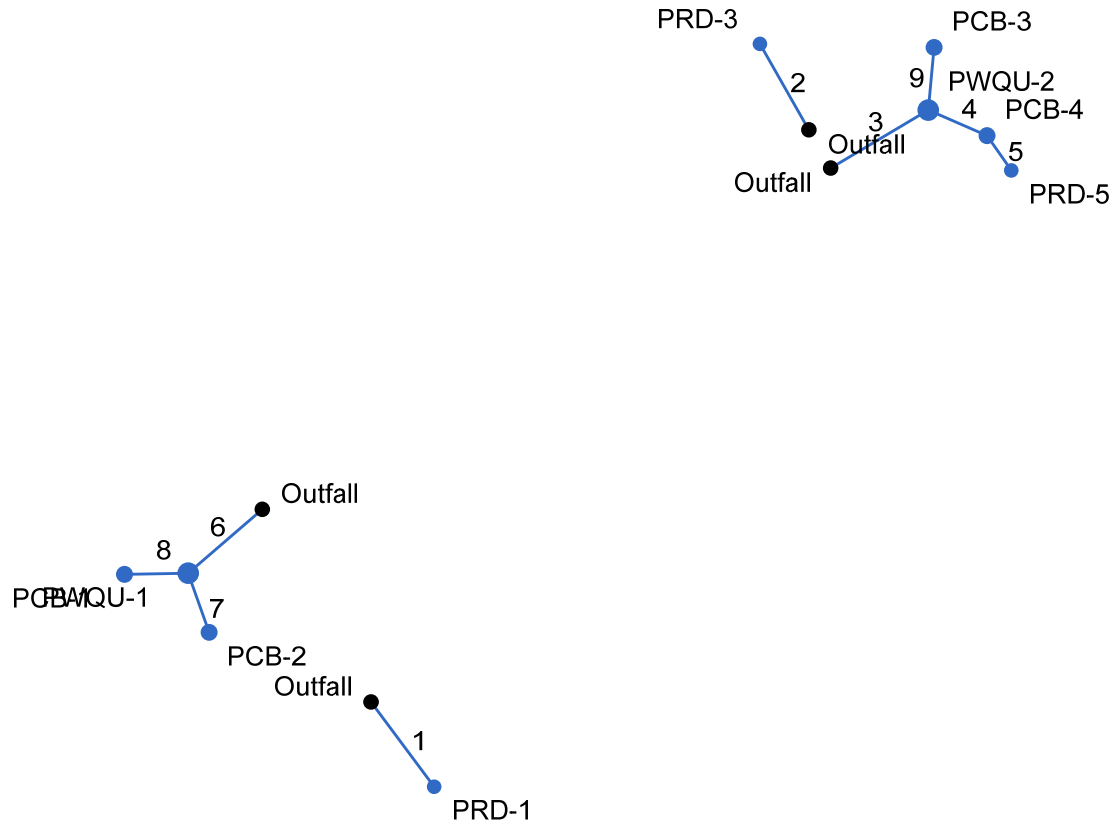

# Storm Sewer Tabulation

Station		Len (ft)	Drng Area		Rnoff coeff (C)	Area x C		Tc		Rain (l) (in/hr)	Total flow (cfs)	Cap full (cfs)	Vel (ft/s)	Pipe		Invert Elev		HGL Elev		Grnd / Rim Elev		Line ID
Line	To Line		Incr (ac)	Total (ac)		Incr	Total	Inlet (min)	Syst (min)					Size (in)	Slope (%)	Dn (ft)	Up (ft)	Dn (ft)	Up (ft)	Dn (ft)	Up (ft)	
1	End	22.795	0.00	0.00	0.00	0.00	0.00	0.0	0.0	0.0	2.20	2.20	4.39	10	1.01	234.00	234.23	234.75	234.93	240.24	240.20	P-D-PIPE-(58)
2	End	21.286	0.00	0.00	0.00	0.00	0.00	0.0	0.0	0.0	2.20	5.05	4.50	10	5.31	234.00	235.13	234.75	235.79	237.81	238.40	P-D-PIPE-(68)
3	End	24.283	0.00	0.00	0.00	0.00	0.00	0.0	0.1	0.0	4.20	3.56	5.43	12	1.00	233.83	234.07	234.76	235.07	237.93	237.70	P-D-PIPE-(20)
4	3	13.604	0.00	0.00	0.00	0.00	0.00	0.0	0.1	0.0	3.00	3.61	3.82	12	1.03	234.17	234.31	235.44	235.54	237.70	238.55	P-D-PIPE-(19)
5	4	9.235	0.00	0.00	0.00	0.00	0.00	0.0	0.0	0.0	0.70	1.19	3.40	8	0.97	235.55	235.64	235.92	236.03	238.55	238.50	P-D-PIPE-(66)
6	End	20.930	0.00	0.00	0.00	0.00	0.00	0.0	0.1	0.0	3.10	5.04	4.57	12	2.00	233.83	234.25	234.71	235.00	239.36	239.57	P-D-PIPE-(3)
7	6	13.598	0.00	0.00	0.00	0.00	0.00	0.0	0.0	0.0	1.80	5.02	3.60	12	1.99	234.35	234.62	235.00	235.19	239.57	239.51	P-D-PIPE-(2)
8	6	13.598	0.00	0.00	0.00	0.00	0.00	0.0	0.0	0.0	1.30	5.02	2.94	12	1.99	234.35	234.62	235.00	235.10	239.57	239.51	P-D-PIPE-(6)
9	3	13.605	0.00	0.00	0.00	0.00	0.00	0.0	0.0	0.0	1.20	3.61	1.53	12	1.03	234.17	234.31	235.44	235.46	237.70	237.45	P-D-PIPE-(18)

Project File: cadexport Rev B.stm

Number of lines: 9

Run Date: 12/2/2025

NOTES: Known Qs only ; c = cir e = ellip b = box

PYD-1

PCB-1

PCB-2

PCB-3

PCB-4

PRD-1

PRD-3

PRD-5

Subcat

Reach

Pond

Link

**Routing Diagram for 250511 - INLET**

Prepared by R Levesque Associates, Printed 12/8/2025  
HydroCAD® 10.20-7a s/n 13073 © 2025 HydroCAD Software Solutions LLC

**250511 - INLET**

Prepared by R Levesque Associates  
HydroCAD® 10.20-7a s/n 13073 © 2025 HydroCAD Software Solutions LLC

Printed 12/8/2025  
Page 2

**Rainfall Events Listing (selected events)**

Event#	Event Name	Storm Type	Curve	Mode	Duration (hours)	B/B	Depth (inches)	AMC
1	100-Year	Type III 24-hr		Default	24.00	1	7.96	2

**250511 - INLET**

Type III 24-hr 100-Year Rainfall=7.96"

Prepared by R Levesque Associates

Printed 12/8/2025

HydroCAD® 10.20-7a s/n 13073 © 2025 HydroCAD Software Solutions LLC

Page 3

Time span=0.00-36.00 hrs, dt=0.05 hrs, 721 points  
Runoff by SCS TR-20 method, UH=SCS, Weighted-Q  
Reach routing by Stor-Ind+Trans method - Pond routing by Stor-Ind method

<b>Subcatchment PCB-1:</b>	Runoff Area=8,568 sf 70.91% Impervious Runoff Depth=6.47" Tc=6.0 min CN=WQ Runoff=1.3 cfs 4,618 cf
<b>Subcatchment PCB-2:</b>	Runoff Area=13,212 sf 52.76% Impervious Runoff Depth=5.69" Tc=6.0 min CN=WQ Runoff=1.8 cfs 6,260 cf
<b>Subcatchment PCB-3:</b>	Runoff Area=8,197 sf 51.96% Impervious Runoff Depth=5.65" Tc=6.0 min CN=WQ Runoff=1.1 cfs 3,861 cf
<b>Subcatchment PCB-4:</b>	Runoff Area=16,257 sf 57.68% Impervious Runoff Depth=5.90" Tc=6.0 min CN=WQ Runoff=2.3 cfs 7,990 cf
<b>Subcatchment PRD-1:</b>	Runoff Area=12,489 sf 100.00% Impervious Runoff Depth=7.72" Tc=6.0 min CN=98 Runoff=2.2 cfs 8,035 cf
<b>Subcatchment PRD-3:</b>	Runoff Area=12,531 sf 99.66% Impervious Runoff Depth=7.71" Tc=6.0 min CN=WQ Runoff=2.2 cfs 8,047 cf
<b>Subcatchment PRD-5:</b>	Runoff Area=4,163 sf 100.00% Impervious Runoff Depth=7.72" Tc=6.0 min CN=98 Runoff=0.7 cfs 2,678 cf
<b>Subcatchment PYD-1:</b>	Runoff Area=29,240 sf 3.45% Impervious Runoff Depth=3.48" Tc=6.0 min CN=WQ Runoff=2.6 cfs 8,481 cf

**Total Runoff Area = 104,657 sf Runoff Volume = 49,970 cf Average Runoff Depth = 5.73"**  
**45.70% Pervious = 47,826 sf 54.30% Impervious = 56,831 sf**

**250511 - INLET**

Type III 24-hr 100-Year Rainfall=7.96"

Prepared by R Levesque Associates

Printed 12/8/2025

HydroCAD® 10.20-7a s/n 13073 © 2025 HydroCAD Software Solutions LLC

Page 4

**Summary for Subcatchment PCB-1:**

Runoff = 1.3 cfs @ 12.09 hrs, Volume= 4,618 cf, Depth= 6.47"

Runoff by SCS TR-20 method, UH=SCS, Weighted-Q, Time Span= 0.00-36.00 hrs, dt= 0.05 hrs  
Type III 24-hr 100-Year Rainfall=7.96"

Area (sf)	CN	Description
2,493	61	>75% Grass cover, Good, HSG B
6,076	98	Paved parking, HSG B
8,568		Weighted Average
2,493	61	29.09% Pervious Area
6,076	98	70.91% Impervious Area

Tc (min)	Length (feet)	Slope (ft/ft)	Velocity (ft/sec)	Capacity (cfs)	Description
6.0					<b>Direct Entry,</b>

**250511 - INLET**

Type III 24-hr 100-Year Rainfall=7.96"

Prepared by R Levesque Associates

Printed 12/8/2025

HydroCAD® 10.20-7a s/n 13073 © 2025 HydroCAD Software Solutions LLC

Page 5

**Summary for Subcatchment PCB-2:**

Runoff = 1.8 cfs @ 12.09 hrs, Volume= 6,260 cf, Depth= 5.69"

Runoff by SCS TR-20 method, UH=SCS, Weighted-Q, Time Span= 0.00-36.00 hrs, dt= 0.05 hrs  
Type III 24-hr 100-Year Rainfall=7.96"

Area (sf)	CN	Description
6,242	61	>75% Grass cover, Good, HSG B
6,970	98	Paved parking, HSG B
13,212		Weighted Average
6,242	61	47.24% Pervious Area
6,970	98	52.76% Impervious Area

Tc (min)	Length (feet)	Slope (ft/ft)	Velocity (ft/sec)	Capacity (cfs)	Description
6.0					<b>Direct Entry,</b>

**250511 - INLET**

Type III 24-hr 100-Year Rainfall=7.96"

Prepared by R Levesque Associates

Printed 12/8/2025

HydroCAD® 10.20-7a s/n 13073 © 2025 HydroCAD Software Solutions LLC

Page 6

**Summary for Subcatchment PCB-3:**

Runoff = 1.1 cfs @ 12.09 hrs, Volume= 3,861 cf, Depth= 5.65"

Runoff by SCS TR-20 method, UH=SCS, Weighted-Q, Time Span= 0.00-36.00 hrs, dt= 0.05 hrs  
Type III 24-hr 100-Year Rainfall=7.96"

Area (sf)	CN	Description
3,938	61	>75% Grass cover, Good, HSG B
4,259	98	Paved parking, HSG B
8,197		Weighted Average
3,938	61	48.04% Pervious Area
4,259	98	51.96% Impervious Area

Tc (min)	Length (feet)	Slope (ft/ft)	Velocity (ft/sec)	Capacity (cfs)	Description
6.0					<b>Direct Entry,</b>

**250511 - INLET**

Type III 24-hr 100-Year Rainfall=7.96"

Prepared by R Levesque Associates

Printed 12/8/2025

HydroCAD® 10.20-7a s/n 13073 © 2025 HydroCAD Software Solutions LLC

Page 7

**Summary for Subcatchment PCB-4:**

Runoff = 2.3 cfs @ 12.09 hrs, Volume= 7,990 cf, Depth= 5.90"

Runoff by SCS TR-20 method, UH=SCS, Weighted-Q, Time Span= 0.00-36.00 hrs, dt= 0.05 hrs  
Type III 24-hr 100-Year Rainfall=7.96"

Area (sf)	CN	Description
6,880	61	>75% Grass cover, Good, HSG B
9,377	98	Paved parking, HSG B
16,257		Weighted Average
6,880	61	42.32% Pervious Area
9,377	98	57.68% Impervious Area

Tc (min)	Length (feet)	Slope (ft/ft)	Velocity (ft/sec)	Capacity (cfs)	Description
6.0					<b>Direct Entry,</b>

**250511 - INLET**

Type III 24-hr 100-Year Rainfall=7.96"

Prepared by R Levesque Associates

Printed 12/8/2025

HydroCAD® 10.20-7a s/n 13073 © 2025 HydroCAD Software Solutions LLC

Page 8

**Summary for Subcatchment PRD-1:**

Runoff = 2.2 cfs @ 12.09 hrs, Volume= 8,035 cf, Depth= 7.72"

Runoff by SCS TR-20 method, UH=SCS, Weighted-Q, Time Span= 0.00-36.00 hrs, dt= 0.05 hrs  
Type III 24-hr 100-Year Rainfall=7.96"

Area (sf)	CN	Description
12,489	98	Roofs, HSG B
12,489	98	100.00% Impervious Area

Tc (min)	Length (feet)	Slope (ft/ft)	Velocity (ft/sec)	Capacity (cfs)	Description
6.0					<b>Direct Entry,</b>

**250511 - INLET**

Type III 24-hr 100-Year Rainfall=7.96"

Prepared by R Levesque Associates

Printed 12/8/2025

HydroCAD® 10.20-7a s/n 13073 © 2025 HydroCAD Software Solutions LLC

Page 9

**Summary for Subcatchment PRD-3:**

Runoff = 2.2 cfs @ 12.09 hrs, Volume= 8,047 cf, Depth= 7.71"

Runoff by SCS TR-20 method, UH=SCS, Weighted-Q, Time Span= 0.00-36.00 hrs, dt= 0.05 hrs  
Type III 24-hr 100-Year Rainfall=7.96"

Area (sf)	CN	Description
43	61	>75% Grass cover, Good, HSG B
12,489	98	Roofs, HSG B
12,531		Weighted Average
43	61	0.34% Pervious Area
12,489	98	99.66% Impervious Area

Tc (min)	Length (feet)	Slope (ft/ft)	Velocity (ft/sec)	Capacity (cfs)	Description
6.0					<b>Direct Entry,</b>

**250511 - INLET**

Type III 24-hr 100-Year Rainfall=7.96"

Prepared by R Levesque Associates

Printed 12/8/2025

HydroCAD® 10.20-7a s/n 13073 © 2025 HydroCAD Software Solutions LLC

Page 10

**Summary for Subcatchment PRD-5:**

Runoff = 0.7 cfs @ 12.09 hrs, Volume= 2,678 cf, Depth= 7.72"

Runoff by SCS TR-20 method, UH=SCS, Weighted-Q, Time Span= 0.00-36.00 hrs, dt= 0.05 hrs  
Type III 24-hr 100-Year Rainfall=7.96"

Area (sf)	CN	Description
4,163	98	Roofs, HSG B
4,163	98	100.00% Impervious Area

Tc (min)	Length (feet)	Slope (ft/ft)	Velocity (ft/sec)	Capacity (cfs)	Description
6.0					<b>Direct Entry,</b>

**250511 - INLET**

Type III 24-hr 100-Year Rainfall=7.96"

Prepared by R Levesque Associates

Printed 12/8/2025

HydroCAD® 10.20-7a s/n 13073 © 2025 HydroCAD Software Solutions LLC

Page 11

**Summary for Subcatchment PYD-1:**

Runoff = 2.6 cfs @ 12.10 hrs, Volume= 8,481 cf, Depth= 3.48"

Runoff by SCS TR-20 method, UH=SCS, Weighted-Q, Time Span= 0.00-36.00 hrs, dt= 0.05 hrs  
Type III 24-hr 100-Year Rainfall=7.96"

Area (sf)	CN	Description
16,863	61	>75% Grass cover, Good, HSG B
234	74	>75% Grass cover, Good, HSG C
1,009	98	Roofs, HSG B
8,399	55	Woods, Good, HSG B
2,734	70	Woods, Good, HSG C
29,240		Weighted Average
28,231	60	96.55% Pervious Area
1,009	98	3.45% Impervious Area

Tc (min)	Length (feet)	Slope (ft/ft)	Velocity (ft/sec)	Capacity (cfs)	Description
6.0					<b>Direct Entry,</b>



## **Appendix E: MassDEP Calculations**

- Impervious Area Calculations
- Recharge Calculation
- Stage Storage Chart – Subsurface Infiltration Basin
- Water Quality Flow Rate Calculations – PWQU-1
- Water Quality Flow Rate Calculations – PWQU-2
- Water Quality Conversion Table
- TSS Removal Worksheet – Subsurface Infiltration Basin
- Drawdown Calculation
- Barracuda Max Info Sheet
- NJDEP Barracuda Max Certification
- Barracuda Max Maintenance Guide



**Standard 3: Recharge Calculations**

Impervious Area Calculations

**Existing Total Impervious Area**

Sub-Catchment	Roof (sf)	Other Impervious (sf)	Sum (sf)
ES-1	2,787	0	2,787
	2,787	0	2,787

**Proposed Total Impervious Area**

Sub-Catchment	Roof (sf)	Other Impervious (sf)	Sum (sf)	
PS-1A	1,009	0	1,009	
PS-1B	28,779	27,201	55,980	Tributary to Basin
PS-1C	0	0	0	
PS-1D	0	0	0	
	29,788	27,201	56,989	

Total Existing Impervious Area	2,787 SF
Total Proposed Impervious Area	56,989 SF
Total New Impervious Area	54,202 SF
Total Impervious Area Tributary to Infiltration Basin	55,980 SF

**Standard 3: Recharge Calculations -Subsurface Infiltration Basin**

$$R_v \text{ (required)} = F \times \text{Impervious Area}$$

where:  $R_v$  = Required Recharge Volume (cu. ft.)

F = Target Depth Factor	0.60 inch (A-soils)
	0.35 inch (B-soils)
	0.25 inch (C-soils)
	0.10 inch (D-soils)

**New Impervious Area by Hydrologic Soil Type**

Impervious Area (A-soils)	0 sq. ft.	0.0%
Impervious Area (B-soils)	54,202 sq. ft.	100.0%
Impervious Area (C-soils)	0 sq. ft.	0.0%
Impervious Area (D-soils)	0 sq. ft.	0.0%
<b>Total Impervious area</b>	<b>54,202 sq. ft.</b>	<b>100.0%</b>

**Required Recharge Volume Sizing ( $R_v$ )**

$$R_v \text{ (required)} = \sum [F_{\text{Soil Type}} \times \text{Impervious Area}_{\text{Soil Type}}] \times 1 \text{ ft./12 in.}$$

$$R_v \text{ (required)} = 1,581 \text{ cu. ft.}$$

$$R_v \text{ (provided)} = 12,622 \text{ cu. ft.*} \quad (\text{Subsurface Infiltration Basin})$$

\*Volume represents the available storage in subsurface infiltration basin below orifice elevation 234.83 ft

**250511 - POST (Tc-50)**

Prepared by R Levesque Associates

HydroCAD® 10.20-7a s/n 13073 © 2025 HydroCAD Software Solutions LLC

Type III 24-hr 100-Year Rainfall=7.96"

Printed 12/8/2025

**Stage-Area-Storage for Pond 1P:**

Elevation (feet)	Surface (sq-ft)	Storage (cubic-feet)	Elevation (feet)	Surface (sq-ft)	Storage (cubic-feet)
232.83	<b>8,967</b>	0	235.48	8,967	16,615
232.88	8,967	179	235.53	8,967	16,891
232.93	8,967	359	235.58	8,967	17,160
232.98	8,967	538	235.63	8,967	17,423
233.03	8,967	717	235.68	8,967	17,678
233.08	8,967	897	235.73	8,967	17,923
233.13	8,967	1,076	235.78	8,967	18,157
233.18	8,967	1,255	235.83	8,967	18,379
233.23	8,967	1,435	235.88	8,967	18,590
233.28	8,967	1,614	235.93	8,967	18,793
233.33	8,967	1,793	235.98	8,967	18,990
233.38	8,967	2,176	236.03	8,967	19,180
233.43	8,967	2,557	236.08	8,967	19,364
233.48	8,967	2,938	236.13	8,967	19,543
233.53	8,967	3,317	236.18	8,967	19,723
233.58	8,967	3,695	236.23	8,967	19,902
233.63	8,967	4,072	236.28	8,967	20,081
233.68	8,967	4,448	236.33	8,967	20,261
233.73	8,967	4,822	236.38	8,967	20,440
233.78	8,967	5,195	236.43	8,967	20,619
233.83	8,967	5,567	236.48	8,967	20,799
233.88	8,967	5,937	236.53	8,967	20,978
233.93	8,967	6,306	236.58	8,967	<b>21,157</b>
233.98	8,967	6,673			
234.03	8,967	7,039			
234.08	8,967	7,403			
234.13	8,967	7,765			
234.18	8,967	8,125			
234.23	8,967	8,484			
234.28	8,967	8,841			
234.33	8,967	9,196			
234.38	8,967	9,549			
234.43	8,967	9,900			
234.48	8,967	10,248			
234.53	8,967	10,595			
234.58	8,967	10,939			
234.63	8,967	11,281			
234.68	8,967	11,620			
234.73	8,967	11,957			
234.78	8,967	12,291			
<b>234.83</b>	<b>8,967</b>	<b>12,622</b>			
234.88	8,967	12,950			
234.93	8,967	13,276			
234.98	8,967	13,598			
235.03	8,967	13,917			
235.08	8,967	14,233			
235.13	8,967	14,545			
235.18	8,967	14,854			
235.23	8,967	15,158			
235.28	8,967	15,459			
235.33	8,967	15,755			
235.38	8,967	16,047			
235.43	8,967	16,333			

**Standard 4: Water Quality - PWQU-1**

**Water Quality Volume Conversion to Flow Rate**

**Note:** Required water quality volume 0.5-inch of runoff

$$Q = (qu) (A) (WQV)$$

where: **Q** = peak flow rate associated with first 0.5-inch of runoff (c.f.s.)

**qu** = unit peak discharge (csm/in) - value taken from table based on  $t_c$

**A** = impervious surface drainage area (sq. mi.)

**WQV** = water quality volume in watershed inches

**· Proposed Water Quality Unit (PWQU-1)**

$t_c$ =	0.100 hrs	
$qu$ =	752 csm/in	(from table)
<b>A</b> =	0.00047 sq. mi.*	
<b>WQV</b> =	0.5 inch	

$$Q_{0.5} = 0.18 \text{ c.f.s}$$

The Baracuda Max Model S4 provides 80% TSS treatment of flows up to 1.52 c.f.s.

\* Only includes impervious area tributary to water quality unit

### **Standard 4: Water Quality - PWQU-2**

#### **Water Quality Volume Conversion to Flow Rate**

**Note:** Required water quality volume 0.5-inch of runoff

$$Q = (qu) (A) (WQV)$$

where: **Q** = peak flow rate associated with first 0.5-inch of runoff (c.f.s.)

**qu** = unit peak discharge (csm/in) - value taken from table based on  $t_c$

**A** = impervious surface drainage area (sq. mi.)

**WQV** = water quality volume in watershed inches

#### **· Proposed Water Quality Unit (PWQU-2)**

$t_c$ =	0.100 hrs	
$qu$ =	752 csm/in	(from table)
<b>A</b> =	0.00049 sq. mi.*	
<b>WQV</b> =	0.5 inch	

$$Q_{0.5} = 0.18 \text{ c.f.s}$$

The Baracuda Max Model S4 provides 80% TSS treatment of flows up to 1.52 c.f.s.

\* Only includes impervious area tributary to water quality unit

Figure 2: For First ½-inch of Runoff, Table of qu values for Ia/P Curve = 0.0.058, listed by tc, for Type III Storm Distribution

Tc (Hours)	qu (csm/in)	Tc (Hours)	qu (csm/in)	Tc (Hours)	qu (csm/in)	Tc (Hours)	qu (csm/in)
0.01	821	1.8	246	5.3	116	8.8	77
0.03	821	1.9	238	5.4	115	8.9	76
0.05	813	2	230	5.5	113	9	76
0.067	794	2.1	223	5.6	112	9.1	75
0.083	773	2.2	217	5.7	110	9.2	74
0.1	752	2.3	211	5.8	109	9.3	74
0.116	733	2.4	205	5.9	107	9.4	73
0.133	713	2.5	200	6	106	9.5	72
0.15	694	2.6	194	6.1	104	9.6	72
0.167	677	2.7	190	6.2	103	9.7	71
0.183	662	2.8	185	6.3	102	9.8	70
0.2	646	2.9	181	6.4	100	9.9	70
0.217	632	3	176	6.5	99	10	69
0.233	619	3.1	173	6.6	98		
0.25	606	3.2	169	6.7	97		
0.3	572	3.3	165	6.8	96		
0.333	552	3.4	162	6.9	94		
0.35	542	3.5	158	7	93		
0.4	516	3.6	155	7.1	92		
0.416	508	3.7	152	7.2	91		
0.5	472	3.8	149	7.3	90		
0.583	443	3.9	147	7.4	89		
0.6	437	4	144	7.5	88		
0.667	417	4.1	141	7.6	87		
0.7	408	4.2	139	7.7	86		
0.8	383	4.3	136	7.8	85		
0.9	361	4.4	134	7.9	84		
1	342	4.5	132	8	84		
1.1	325	4.6	130	8.1	83		
1.2	311	4.7	128	8.2	82		
1.3	297	4.8	126	8.3	81		
1.4	285	4.9	124	8.4	80		
1.5	274	5	122	8.5	79		
1.6	264	5.1	120	8.6	79		
1.7	254	5.2	118	8.7	78		

**TSS Removal Form - Infiltration Basin**

<b>Pre-Treatment</b>	BMP	TSS Removal Rate	Starting TSS Load	Amount Removed	Remaining Load
	Deep Sump Hooded Catch Basin	0.25	1.00	0.25	0.75
	Proprietary Sedimentation Device	0.50	0.75	0.38	0.38

Pre-Treatment TSS Removal = **63%**

<b>Total TSS Removal</b>	BMP	TSS Removal Rate	Starting TSS Load	Amount Removed	Remaining Load
	Subsurface Infiltration	0.8	1.00	0.8	0.20

Total TSS Removal = **80%**

### Drawdown Analysis

$$T_{\text{DRAWDOWN}} = \frac{R_v}{KA}$$

where:  $T_{\text{DRAWDOWN}}$  = time in hours

$R_v$  = required recharge volume (cu. ft.)

$K$  = Rawls rate                    **8.27 inches/hour (A-soils)\***

**1.02 inches/hour (B-soils)\***

**0.27 inches/hour (C-soils)\***

$A$  = bottom area of recharge facility (sq. ft.)

### Subsurface Infiltration Basin

$$R_v = 12,622 \text{ cu. ft.}$$

$$A = 8,967 \text{ sq. ft.}$$

$$T_{\text{DRAWDOWN}} = 16.6 \text{ hours} < 72 \text{ hours} \quad (\text{B-soils})$$

# Barracuda<sup>®</sup> Max

The Barracuda Max is market-changing stormwater quality technology. This high-performance vortex hydrodynamic separator is designed to remove total suspended solids in order to protect our precious receiving waters. The Barracuda Max is also an outstanding value that offers multiple pipe configurations, and quick installation. The “Max” version of the Barracuda is built on the base platform of the original ADS Barracuda with improved removal efficiencies and installation components.

## Features

- Single manhole design
- No elevation loss between the inlet and outlet
- Variable inlet/outlet angle configurations (not just 180 degree orientation)
- Internal bypass for inline installation (where applicable)
- Revolutionary, patent pending “teeth” mitigate turbulence in the sump area to prevent resuspension of captured contaminants
- Available with grated drop inlet configuration
- Available with trash and/or oil capture add-ons

## Benefits

- Internal components are in stock for quick delivery
- The S3, S4, S6, and S8 can be installed in a standard 36” (900 mm), 48” (1200 mm), 72” (1800 mm), and 96” (2400 mm) precast manhole, respectively
- The S3 & S4 can be provided factory installed within a 36” (900 mm) and 48” (1200 mm) ADS HP manhole and delivered to the jobsite
- The Barracuda Max “teeth” and deflector plate apparatus are fabricated and designed for quick and easy field assembly
- Designed for easy maintenance using a vacuum truck or similar equipment.
- Inspection and maintenance are performed from the surface with no confined space entry

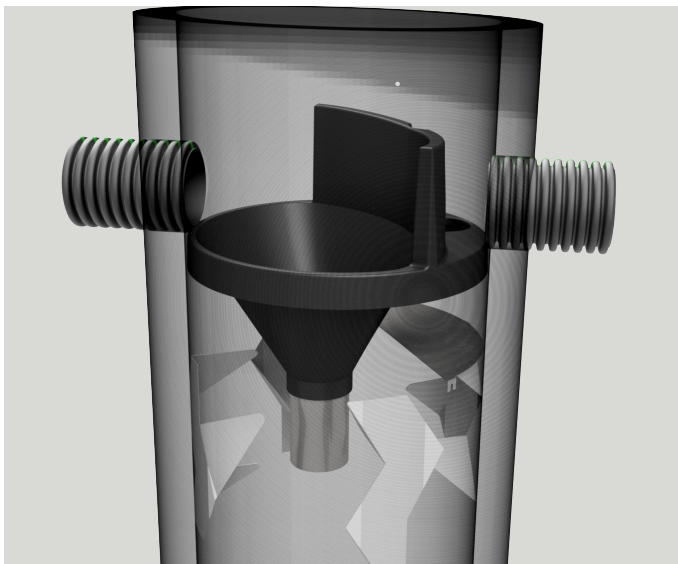

# Barrucuda Specification

## Materials and Design

- Concrete Structures: Designed for H-20 traffic loading and applicable soil loads or as otherwise determined by a Licensed Professional Engineer. The materials and structural design of the devices shall be per ASTM C857 and ASTM C858.
- 36" (900 mm) and 48" (1200 mm) HP Manhole Structures: Made from an impact modified copolymer polypropylene meeting the material requirements of ASTM F2764. The eccentric cone reducer shall be manufactured from polyethylene material meeting ASTM D3350 cell class 213320C. Gaskets shall be made of material meeting the requirements of ASTM F477.
- Separator internals shall be substantially constructed of stainless steel, polyethylene or other thermoplastic material approved by the manufacturer.

## Performance

- The stormwater treatment unit shall be an inline unit capable of conveying 100% of the design peak flow. If peak flow rates exceed maximum hydraulic rate, the unit shall be installed offline.
- The Barracuda Max unit shall be designed to remove at least 80% of the suspended solids on an annual aggregate removal basis. Said removal shall be based on full-scale third party testing using OK-110 media gradation or equivalent and 300 mg/L influent concentration. Said full scale testing shall have included sediment capture based on actual total mass collected by the stormwater treatment unit.

- OR -

The Barracuda Max unit shall be designed to remove at least 50% of TSS using a media mix with  $d_{50}$ =75 micron and 200 mg/L influent concentration.

- OR -

The Barracuda Max unit shall be designed to remove at least 50% of TSS per current NJDEP/NJCAT HDS protocol.

- The stormwater treatment unit internals shall consist of (1) separator cone assembly, and (1) sump assembly, which includes the "teeth".

Barracuda Max Model	Manhole Diameter	OK-110 (80% removal)	Pretreatment for Infiltration <sup>1</sup>
S3	36" (900 mm)	0.86 CFS (24.1 L/s)	1.65 CFS (46.7 L/s)
S4	48" (1200 mm)	1.52 CFS (43.0 L/s)	2.94 CFS (83.3 L/s)
S6	72" (1800 mm)	3.42 CFS (96.8 L/s)	6.62 CFS (187.5 L/s)
S8	96" (2400 mm)	6.08 CFS (172.2 L/s)	11.76 CFS (333.0 L/s)

\* Peak bypass flows are dependent on final design

<sup>1</sup> 50% removal of OK-110.

## Installation

Installation of the stormwater treatment unit(s) shall be performed per manufacturer's installation instructions. Such instructions can be obtained by calling Advanced Drainage Systems at 800-821-6710 or by logging on to [www.adspipe.com](http://www.adspipe.com).





## State of New Jersey

DEPARTMENT OF ENVIRONMENTAL PROTECTION  
Bureau of NJPDES Stormwater Permitting & Water  
Quality Management  
Division of Watershed Protection and Restoration  
401-02B  
Post Office Box 420  
Trenton, New Jersey 08625-0420  
609-633-7021 Fax: 609-777-0432

PHILIP D. MURPHY  
*Governor*

SHEILA Y. OLIVER  
*Lt. Governor*

SHAWN M. LATOURETTE  
*Acting Commissioner*

**April 28, 2021**

Daniel J. Figola, P.E.  
Director of Sustainability Development  
Advanced Drainage Systems, Inc.  
1030 Deer Hollow Drive  
Mt. Airy, MD 21771

Re: MTD Lab Certification  
Barracuda™ MAX Hydrodynamic Separator Stormwater Treatment Device  
On-line Installation

### **TSS Removal Rate 50%**

Dear Mr. Figola:

The Stormwater Management rules under N.J.A.C. 7:8-5.5(b) and 5.7(c) allow the use of manufactured treatment devices (MTDs) for compliance with the design and performance standards at N.J.A.C. 7:8-5 if the pollutant removal rates have been verified by the New Jersey Corporation for Advanced Technology (NJCAT) and have been certified by the New Jersey Department of Environmental Protection (NJDEP). Advanced Drainage Systems, Inc. (ADS) has requested an MTD Laboratory Certification for the Barracuda™ MAX Hydrodynamic Separator stormwater treatment system (Barracuda™ MAX).

The project falls under the “Procedure for Obtaining Verification of a Stormwater Manufactured Treatment Device from New Jersey Corporation for Advance Technology” dated January 25, 2013. The applicable protocol is the “New Jersey Laboratory Testing Protocol to Assess Total Suspended Solids Removal by a Hydrodynamic Sedimentation Manufactured Treatment Device” dated January 25, 2013.

NJCAT verification documents submitted to the NJDEP indicate that the requirements of the aforementioned protocol have been met or exceeded. The NJCAT letter also included a recommended certification TSS removal rate and the required maintenance plan. The NJCAT Verification Report with the Verification Appendix (dated April 2021) for this device is published online at <http://www.njcat.org/verification-process/technology-verification-database.html>.

**The NJDEP certifies the use of the Barracuda™ MAX stormwater treatment system at a TSS removal rate of 50% when designed, operated, and maintained in accordance with the information provided in the Verification Appendix and the following conditions:**

1. The maximum treatment flow rate (MTFR) for the manufactured treatment device (MTD) is calculated using the New Jersey Water Quality Design Storm (1.25 inches in 2 hrs) in N.J.A.C. 7:8-5.5.
2. The Barracuda™ MAX shall be installed using the same configuration reviewed by NJCAT and shall be sized in accordance with the criteria specified in item 6 below.
3. This Barracuda™ MAX cannot be used in series with another MTD or a media filter (such as a sand filter) to achieve an enhanced removal rate for total suspended solids (TSS) removal under N.J.A.C. 7:8-5.5.
4. Additional design criteria for MTDs can be found in Chapter 11.3 of the New Jersey Stormwater Best Management Practices (NJ Stormwater BMP) Manual, which can be found online at [www.njstormwater.org](http://www.njstormwater.org).
5. The maintenance plan for a site using this device shall incorporate, at a minimum, the maintenance requirements for the Barracuda™ MAX. A copy of the maintenance plan is attached to this certification. However, it is recommended to review the maintenance website at <https://assets.ads-pipe.com/m/2c834056a5a22888/original/Barracuda-Maintenance-Guide-MG1-01.pdf> for any changes to the maintenance requirements.
6. Sizing Requirement:

The example on the following page demonstrates the sizing procedure for the Barracuda™ MAX:

Example: A 0.25-acre impervious site is to be treated to 50% TSS removal using an Barracuda™ MAX treatment unit. The impervious site runoff (Q) based on the New Jersey Water Quality Design Storm was determined to be 0.79 cfs.

Maximum Treatment Flow Rate (MTFR) Evaluation:

The site runoff (Q) was based on the following:  
 time of concentration = 10 minutes  
 $i = 3.2$  in/hr (page 74, Fig. 5-16 of the NJ Stormwater BMP Manual)  
 $c = 0.99$  (runoff coefficient for impervious)  
 $Q = ciA = 0.99 \times 3.2 \times 0.25 = 0.79$  cfs

Given the site runoff is 0.79 cfs and based on Table A-1 below, the Barracuda™ MAX Model S3 with an MTFR of 0.85 cfs would be the smallest model that could be used for this site to remove 50% of the TSS from the impervious area without exceeding the MTFR.

The sizing table corresponding to the available system models is noted below. Additional specifications regarding each model can be found in the NJCAT Technology Verification Appendix under Tables A-1 and A-2.

**Table A-1 Barracuda™ MAX HDS Models and Associated MTFRs**

<b>Model</b>	<b>Manhole Diameter (ft)</b>	<b>Maximum Treatment Flow Rate (cfs)</b>	<b>50% Maximum Sediment Storage Area Volume (ft<sup>3</sup>)</b>
Barracuda MAX S3	3	0.85	5.89
Barracuda MAX S4	4	1.52	10.47
Barracuda MAX S5	5	2.37	16.36
Barracuda MAX S6	6	3.40	23.56
Barracuda MAX S8	8	6.08	41.89
Barracuda MAX S10	10	9.48	65.45

A detailed maintenance plan is mandatory for any project with a stormwater BMP subject to the Stormwater Management rules under N.J.A.C. 7:8. The plan must include all of the items identified in the Maintenance requirements section of the Stormwater Management rules under N.J.A.C. 7:8-5.8. Such items include, but are not limited to, the list of inspection and maintenance equipment and tools, specific corrective and preventative maintenance tasks, indication of problems in the system, and training of maintenance personnel. Additional information can be found in Chapter 8: Maintenance and Retrofit of Stormwater Management Measures.

If you have any questions regarding the above information, please contact Lisa Schaefer of my office at [lisa.schaefer@dep.nj.gov](mailto:lisa.schaefer@dep.nj.gov).

Sincerely,

A handwritten signature in blue ink that reads "Gabriel Mahon". The signature is written in a cursive, flowing style.

Gabriel Mahon, Chief  
Bureau of NJPDES Stormwater Permitting & Water Quality Management

Attachment: Maintenance Plan

cc: Chron File  
Richard Magee, NJCAT  
Changi Wu, NJDEP-BFHSE  
Madhu Guru, NJDEP - BFHSE

# Barracuda<sup>®</sup> Max<sup>™</sup> & Barracuda Maintenance Guide

One of Barracuda's advantages is the ease of maintenance. Like any system that collects pollutants, the Barracuda must be maintained for continued effectiveness. Maintenance is a simple procedure performed using a vacuum truck or similar equipment. The systems were designed to minimize the volume of water removed during routine maintenance, reducing disposal costs.

Contractors can access the pollutants stored in the manhole through the manhole cover. This allows them to gain vacuum hose access to the bottom of the manhole to remove sediment and trash. There is no confined space entry necessary for inspection or maintenance.

The entire maintenance procedure typically takes 2 to 4 hours, depending on the system's size, the captured material, and the vacuum truck's capacity.

Local regulations may apply to the maintenance procedure. Safe and legal disposal of pollutants is the responsibility of the maintenance contractor. Maintenance should be performed only by a qualified contractor.

## Inspection and Cleaning Cycle

Periodic inspection is needed to determine the need for and frequency of maintenance. You should begin inspecting as soon as construction is complete and then on an annual basis. Typically, the system needs to be cleaned every 1-3 years.

Excessive oils, fuels or sediments may reduce the maintenance cycle. Periodic inspection is important.

## Determining When to Clean

To determine the sediment depth, the maintenance contractor should lower a stadia rod into the manhole until it contacts the top of the captured sediment and mark that spot on the rod. Then push the probe through to the bottom of the sump and mark that spot to determine sediment depth.

Maintenance should occur when the sediment has reached the levels indicated in the Storage Capacity Chart.

## Barracuda Storage Capacities

Model	Manhole Diameter in. (mm)	Total System Volume Gallons (Liters)	Treatment Chamber Capacity Gallons (Liters)	Standard Sediment Capacity (20" depth) Yards <sup>3</sup> (meters <sup>3</sup> )	NJDEP Sediment Capacity (50% of standard depth) Yards <sup>3</sup> (meters <sup>3</sup> )
S3	36 (900)	264 (999)	212 (803)	0.44 (0.34)	0.22 (0.17)
S4	48 (1200)	665 (2517)	564 (2135)	0.78 (0.60)	0.39 (0.30)
S5	60 (1500)	1040 (3937)	881 (3335)	1.21 (0.93)	0.61 (0.47)
S6	72 (1800)	1497 (5667)	1269 (4804)	1.75 (1.34)	0.88 (0.67)
S8	96 (2400)	4196 (15884)	3835 (14517)	3.10 (2.37)	1.55 (1.19)
S10	120 (3000)	7976 (30192)	7496 (28375)	4.85 (3.71)	2.43 (1.86)

## Maintenance Instructions

1. Remove the manhole cover to provide access to the pollutant storage. Pollutants are stored in the sump, below the bowl assembly visible from the surface. Access this area through the 8" (200 mm), 10" (250 mm), 15" (375 mm) or 20" (500 mm) diameter access cylinder.
2. Use a vacuum truck or other similar equipment to remove all water, debris, oils and sediment. See figure 1.
3. Use a high pressure hose to clean the manhole of all the remaining sediment and debris. Then, use the vacuum truck to remove the water.
4. Fill the cleaned manhole with water until the level reaches the invert of the outlet pipe.
5. Replace the manhole cover.
6. Dispose of the polluted water, oils, sediment and trash at an approved facility.
  - a. Local regulations prohibit the discharge of solid material into the sanitary system. Check with the local sewer authority for authority to discharge the liquid.
  - b. Some localities treat the pollutants as leachate. Check with local regulators about disposal requirements.
  - c. Additional local regulations may apply to the maintenance procedure.

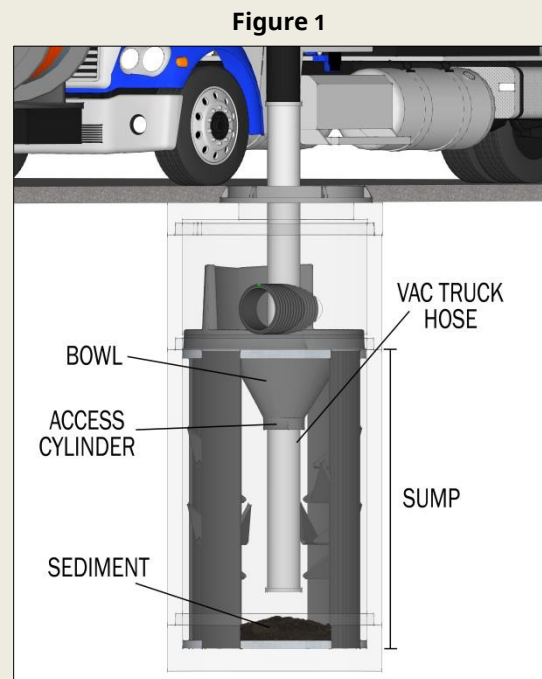

# Maintenance Guide

BaySaver Barracuda™

July 2017

One of the advantages of the BaySaver Barracuda is the ease of maintenance. Like any system that collects pollutants, the BaySaver Barracuda must be maintained for continued effectiveness. Maintenance is a simple procedure performed using a vacuum truck or similar equipment. The systems were designed to minimize the volume of water removed during routine maintenance, reducing disposal costs.

Contractors can access the pollutants stored in the manhole through the manhole cover. This allows them to gain vacuum hose access to the bottom of the manhole to remove sediment and trash. There is no confined space entry necessary for inspection or maintenance.

The entire maintenance procedure typically takes from 2 to 4 hours, depending on the size of the system, the captured material, and the capacity of the vacuum truck.

Local regulations may apply to the maintenance procedure. Safe and legal disposal of pollutants is the responsibility of the maintenance contractor. Maintenance should be performed only by a qualified contractor.

## Inspection and Cleaning Cycle

Periodic inspection is needed to determine the need for and frequency of maintenance. You should begin inspecting as soon as construction is complete and thereafter on an annual basis. Typically, the system needs to be cleaned every 1-3 years.

Excessive oils, fuels or sediments may reduce the maintenance cycle. Periodic inspection is important.

## Determining When to Clean

To determine the sediment depth, the maintenance contractor should lower a stadia rod into the manhole until it contacts the top of the captured sediment and mark that spot on the rod. Then push the probe through to the bottom of the sump and mark that spot to determine sediment depth.

Maintenance should occur when the sediment has reached the levels indicated in the Storage Capacity Chart.

## BaySaver Barracuda Storage Capacities

Model	Manhole Diameter	Treatment Chamber Capacity	Standard Sediment Capacity (20" depth)	NJDEP Sediment Capacity (50% of standard depth)
S3	36"	212 gallons	0.44 cubic yards	0.22 cubic yards
S4	48"	564 gallons	0.78 cubic yards	0.39 cubic yards
S5	60"	881 gallons	1.21 cubic yards	0.61 cubic yards
S6	72"	1269 gallons	1.75 cubic yards	0.88 cubic yards
S8	96"	3835 gallons	3.10 cubic yards	1.55 cubic yards
S10	120"	7496 gallons	4.85 cubic yards	2.43 cubic yards

## Maintenance Instructions

1. Remove the manhole cover to provide access to the pollutant storage. Pollutants are stored in the sump, below the bowl assembly visible from the surface. You'll access this area through the 10" diameter access cylinder.



2. Use a vacuum truck or other similar equipment to remove all water, debris, oils and sediment. See figure 1.
3. Use a high pressure hose to clean the manhole of all the remaining sediment and debris. Then, use the vacuum truck to remove the water.
4. Fill the cleaned manhole with water until the level reaches the invert of the outlet pipe.
5. Replace the manhole cover.
6. Dispose of the polluted water, oils, sediment and trash at an approved facility.
  - Local regulations prohibit the discharge of solid material into the sanitary system. Check with the local sewer authority for authority to discharge the liquid.
  - Some localities treat the pollutants as leachate. Check with local regulators about disposal requirements.
  - Additional local regulations may apply to the maintenance procedure.

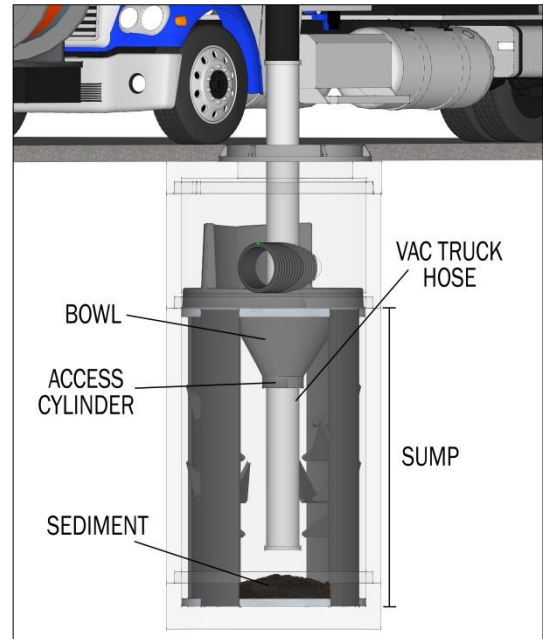

Figure 1

# Barracuda<sup>®</sup> Max & Barracuda Maintenance Guide

One of Barracuda's advantages is the ease of maintenance. Like any system that collects pollutants, the Barracuda must be maintained for continued effectiveness. Maintenance is a simple procedure performed using a vacuum truck or similar equipment. The systems were designed to minimize the volume of water removed during routine maintenance, reducing disposal costs.

Contractors can access the pollutants stored in the manhole through the manhole cover. This allows them to gain vacuum hose access to the bottom of the manhole to remove sediment and trash. There is no confined space entry necessary for inspection or maintenance.

The entire maintenance procedure typically takes 2 to 4 hours, depending on the system's size, the captured material, and the vacuum truck's capacity.

Local regulations may apply to the maintenance procedure. Safe and legal disposal of pollutants is the responsibility of the maintenance contractor. Maintenance should be performed only by a qualified contractor.

## Inspection and Cleaning Cycle

Periodic inspection is needed to determine the need for and frequency of maintenance. You should begin inspecting as soon as construction is complete and then on an annual basis. Typically, the system needs to be cleaned every 1-3 years.

Excessive oils, fuels or sediments may reduce the maintenance cycle. Periodic inspection is important.

## Determining When to Clean

To determine the sediment depth, the maintenance contractor should lower a stadia rod into the manhole until it contacts the top of the captured sediment and mark that spot on the rod. Then push the probe through to the bottom of the sump and mark that spot to determine sediment depth.

Maintenance should occur when the sediment has reached the levels indicated in the Storage Capacity Chart.

## Barracuda Storage Capacities

Model	Manhole Diameter in. (mm)	Total System Volume Gallons (Liters)	Treatment Chamber Capacity Gallons (Liters)	Standard Sediment Capacity (20" depth) Yards <sup>3</sup> (meters <sup>3</sup> )	NJDEP Sediment Capacity (50% of standard depth) Yards <sup>3</sup> (meters <sup>3</sup> )
S3	36 (900)	264 (999)	212 (803)	0.44 (0.34)	0.22 (0.17)
S4	48 (1200)	665 (2517)	564 (2135)	0.78 (0.60)	0.39 (0.30)
S6	72 (1800)	1497 (5667)	1269 (4804)	1.75 (1.34)	0.88 (0.67)
S8	96 (2400)	4196 (15884)	3835 (14517)	3.10 (2.37)	1.55 (1.19)

## Maintenance Instructions

1. Remove the manhole cover to provide access to the pollutant storage. Pollutants are stored in the sump, below the bowl assembly visible from the surface. Access this area through the 8" (200 mm), 10" (250 mm), 15" (375 mm) or 20" (500 mm) diameter access cylinder.
2. Use a vacuum truck or other similar equipment to remove all water, debris, oils and sediment. See figure 1.
3. Use a high pressure hose to clean the manhole of all the remaining sediment and debris. Then, use the vacuum truck to remove the water.
4. Fill the cleaned manhole with water until the level reaches the invert of the outlet pipe.
5. Replace the manhole cover.
6. Dispose of the polluted water, oils, sediment and trash at an approved facility.
  - a. Local regulations prohibit the discharge of solid material into the sanitary system. Check with the local sewer authority for authority to discharge the liquid.
  - b. Some localities treat the pollutants as leachate. Check with local regulators about disposal requirements.
  - c. Additional local regulations may apply to the maintenance procedure.

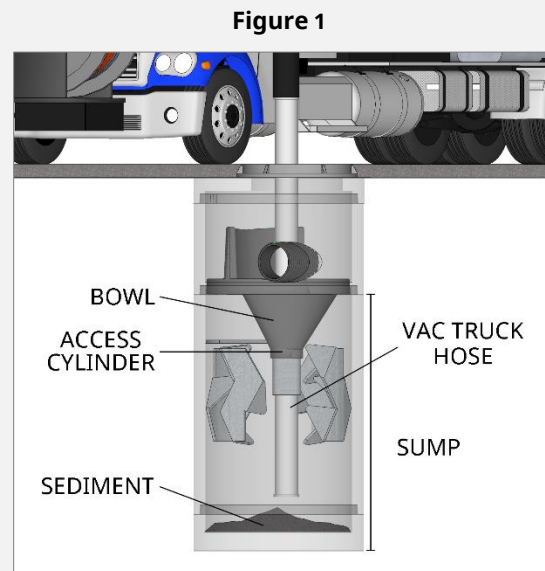

## Appendix F: Construction Period Erosion Control Plan



# Construction Period Erosion Control Plan

## “Deer Meadow Way”

### Project Location:

136 East Street  
South Hadley, Massachusetts 01075  
(Map 35, parcel 6)

### Owner/Applicant:

136 East Street, LLC  
c/o Mr. Gerald Coderre  
383 Newton Street  
South Hadley, Massachusetts 01075

RLA Project File: 250511

**September 30, 2025**

**R LEVESQUE ASSOCIATES, INC**  
**A LAND PLANNING SERVICES COMPANY**

40 School Street · Westfield, MA 01085  
p 413.568.0985 · f 413.568.0986 · [www.rlaland.com](http://www.rlaland.com)



The project shall implement a construction period erosion control plan. The following provides descriptions and guidelines to ensure that the areas surrounding the project site will be protected from excessive sedimentation and runoff during construction.

## **1.1 Construction Period Pollution Prevention And Erosion Control Measures**

### **1.1.1 Preconstruction Notifications And Meetings**

Prior to the start of construction, the contractor shall call together a pre-construction meeting including a representative from the City, the design engineer, contractor, and any pertinent persons that should be in attendance. These requirements shall be the responsibility of the Contractor to arrange, attend, and document.

### **1.1.2 Sediment Barrier And Work Limit**

Before installation of the sediment barriers, the location shall be staked in the field for review and approval by the owner or their representative. To facilitate sediment barrier installation, woody vegetation may then be removed and any required trench may be cut by machine, provided all other ground cover is left intact. No excavation, grading, filling, or removal of vegetative ground cover shall begin until sediment barriers have been installed as shown on the plans and have been inspected by the owner or their representative.

### **1.1.3 Silt Fence**

The bottom of the fence shall be trenched into the ground a minimum of 6" and back-filled with compacted soil. Where trenching is not feasible, silt fence skirt shall be covered with compacted soil or crushed stone. The top of the fabric shall be stretched as tightly as is practical, with intermediate stakes added to correct excessive sags. Stakes shall be driven at least 12" into the ground. Splices between sections shall be made by rolling end stakes together one complete turn and driving into the ground together.

### **1.1.4 Straw Bales**

Straw bales may be used as temporary and moveable control measures, temporary check dams, or as reinforcement for silt fence in areas of concentrated runoff or high fills. Bales shall be tightly butted and staked 12" into the ground. Where used without silt fence in front, the bales shall be trenched 4" into the ground, back-filled with compacted soil, and the spaces between bales shall be chinked with loose hay.

### **1.1.5 Filter Sock (Filtrex Or Equivalent)**

In areas of expected sheet flow, filter sock may be placed directly on the ground without trenching or stakes. In areas of expected concentrated flow, mulch or crushed stone shall be placed along the up-slope face to control and filter underflow. Additional layers of Filter Sock may be required for adequate freeboard. The filter sock shall be staked at 10 feet on-center or in cases where they cannot be staked, utilize heavy concrete blocks to hold in place.

### **1.1.6 Temporary Sedimentation Basins**

Temporary sediment basins may be excavations or bermed stormwater detention structures (depending on grading) that will retain runoff for a sufficient period of time to allow suspended soil particles to settle out prior to discharge. These temporary basins will be located based on construction needs as determined by the contractor and outlet devices will be designed to control velocity and sediment. Points of discharge from sediment basins will be stabilized to minimize erosion. If the temporary basin is to be located within an area of future infiltration as part of the stormwater management system, the excavation shall be limited to one foot above final grade of the infiltration structure.

### **1.1.7 Stocking Additional Materials**

A stock of additional erosion control materials shall be available on the site for emergency repairs and temporary measures. Stock shall be replenished when decreased to 50% of the numbers below. Stock shall include:

Straw Bales – 10 (kept dry) with 20 oak stakes

Or

Silt Fence – 30 Linear feet.

Or

Filter Sock – 4 – 8 foot sections (kept dry)

Washed Stone – One (1) cubic yard, ¾" to 2" diameter

### **1.1.8 Trench Protection**

Open trenches shall be protected from accumulation of surface water or groundwater that could result in erosion of the trench and discharge of sediment. Where feasible, spoil shall be stockpiled on the up-slope side of the trench to prevent entrance of surface runoff. Backfill shall be crowned to allow for settlement and to avoid concentration of runoff on top of the trench.

### **1.1.9 Site Stabilization – Temporary**

Where a portion of the site will not be subject to construction activity for over 14 days, measures shall be taken to provide temporary stabilization of that inactive portion of the site, within 14 days of the cessation of construction activity. Stabilization measures may include seeding for temporary cover, mulching, or other measures to protect exposed soil from erosion and prevent sediment movement.

### **1.1.10 Site Stabilization – Permanent**

Within 14 days of completion of loaming and finish grading on any portion of the site, that area shall be seeded or planted for permanent cover (season permitting) in accordance with USDA NRCS guidelines or equivalent.

### 1.1.11 Roadway Sweeping

The entrance to the site and affected portions of the access drive or paved project areas shall be swept as needed to control sediment runoff into storm drains or waterways and to control blowing dust.

## 1.2 Short-Term Erosion Control Maintenance

The following provides short-term erosion control maintenance guidelines and requirements.

1. The contractor or subcontractor will be responsible for implementing each control shown on the sedimentation and erosion control plan.
2. All erosion and sediment control devices shall be properly maintained during all phases of construction until the completion of all construction activities and all disturbed areas have been stabilized. Additional control measures will be installed during construction in order to control erosion and/or off-site sedimentation if deemed necessary by on-site inspection.
3. Effective erosion control measures shall be initiated prior to the commencement of clearing, grading, excavation, or other operations that will disturb the natural protection.
4. All sediment and erosion control devices shall be inspected at least once every seven (7) calendar days and after any storm event greater than 0.5 inches of precipitation during any 24-hour period, and the inspection shall be documented in writing. Damaged or ineffective devices shall be repaired or replaced, as necessary.
5. The contractor shall take all reasonable precautions to avoid excess erosion of the site due to the construction of this project.
6. Silt shall be removed from behind barriers if greater than 6-inches deep or as needed. Sediment that is collected in structures shall be disposed of properly and covered if stored on-site
7. Damaged or deteriorated items will be repaired immediately after identification.
8. All ditches shall be stabilized as soon as is practicable to minimize erosion.
9. The contractor shall maintain all erosion control devices in a good, working state of repair. Upon complete stabilization of any tributary areas, the erosion control devices shall be removed and disposed of so as to cause no off-site siltation.
10. Inspect and maintain construction entrance stone such that sediment does not track onto the street. Any sediment tracked onto the street shall be swept daily.
11. After catch basins have been constructed, the contractor shall protect the inlets by constructing inlet protection as shown on the plans.
12. Once the site has been paved, all catch basin inlets shall receive a silt sack type protection.
13. Erosion control measures shall remain in place until all disturbed earth has been substantially stabilized. After removal of structures, disturbed areas shall be regraded and stabilized as necessary.

## **Appendix G: Long-Term Operation and Maintenance Plan**

- Long-Term Operation & Maintenance Plan Narrative
- StormTech Chamber Info Sheet
- Isolator Row O&M Manual
- Barracuda Concrete Installation Guide
- Barracuda Max Maintenance Guide
- O&M Checklist



# Long-Term Operation & Maintenance Plan

## “Deer Meadow Way”

### **Project Location:**

136 East Street  
South Hadley, Massachusetts 01075  
(Map 35, parcel 6)

### **Owner/Applicant:**

136 East Street, LLC  
c/o Mr. Gerald Coderre  
383 Newton Street  
South Hadley, Massachusetts 01075

RLA Project File: 250511

**September 30, 2025**

**Revised: December 4, 2025**

# R LEVESQUE ASSOCIATES, INC

**A LAND PLANNING SERVICES COMPANY**

40 School Street · Westfield, MA 01085  
p 413.568.0985 · f 413.568.0986 · [www.rlaland.com](http://www.rlaland.com)



## I. Long-Term Stormwater Maintenance Program:

---

This Long-Term Operation and Maintenance Plan (O&M) identifies inspection and maintenance requirements for the proposed stormwater management system. The O&M references guidelines set forth by the Stormwater Management Handbook developed by the Massachusetts Department of Environmental Protection.

**Owner/Responsible Party\*:**

136 East Street, LLC  
c/o Mr. Gerald Coderre  
383 Newton Street  
South Hadley, Massachusetts 01075

  
\_\_\_\_\_  
Signature of Authorized Representative

\*The party listed shall be responsible for implementation and record keeping of the requirements listed in this operation and maintenance plan. Upon sale of property or any other transition of ownership, the responsible party shall be reinstated as the new owner or any other group created as determined by the owner.

## 2. Inspection and Maintenance Program:

Regular inspection and routine maintenance are necessary to ensure that the stormwater management system continues to control and treat runoff. The following lists the inspection schedule and maintenance procedures for the proposed stormwater Best Management Practices:

BMP	Inspection Schedule	Maintenance Schedule	Maintenance Procedures
Bituminous Concrete Pavement	Four times per year	Twice per year	<ul style="list-style-type: none"> <li>Roadway to be swept in March or April following snow melt and again in late November or early December to remove fallen leaves and debris.</li> </ul>
Deep-Sump Catch Basins	Four times per year	Four times per year	<ul style="list-style-type: none"> <li>Remove sediment once deposits reach one half the depth from the bottom sump to the lowest invert.</li> </ul>
Stormwater Piping	Once per year	Once per year	<ul style="list-style-type: none"> <li>Inspect pipe entrances in catch basins and manholes and remove any blockages.</li> </ul>
Water Quality Unit*	As specified by the manufacturer	As specified by the manufacturer	<ul style="list-style-type: none"> <li>Clean the unit using the method specified by the manufacturer. Vactor trucks are typically used to clean these units.</li> </ul>
Subsurface Infiltration Basin	Twice per year	Twice Per year	<ul style="list-style-type: none"> <li>Verify that the inlet structure has no accumulation of sediment.</li> </ul>
Isolator Row(s)**	Every 6 months for the first year. Once per year thereafter	3 inches of accumulated sediment	<ul style="list-style-type: none"> <li>Measure accumulated sediment depth. Once sediment reaches 3 inches, maintenance cleaning should be performed.</li> </ul>
Flared End Section	Four times per year	As Needed	<ul style="list-style-type: none"> <li>Remove any debris or vegetation around the flared end section such that flow out of the structure is not impeded.</li> </ul>
Roof Leaders	Once per year	Once per year	<ul style="list-style-type: none"> <li>Inspect downspout connections at grade and remove any blockages.</li> <li>Open and inspect cleanout locations and remove any blockages.</li> </ul>
Level Spreader	Every six months during the first year. Annually thereafter.	As Needed	<ul style="list-style-type: none"> <li>Remove sediment from the toe of slope and/or riprap voids.</li> <li>Repair gullies and reseed bare spots immediately.</li> </ul>

\*See attached Device Operation and Maintenance Guides

\*\*See attached Maintenance Guide

See the attached Long-Term O&M Inspection Checklist for record keeping purposes.

### 3. Additional Long-Term Operation and Maintenance Items

---

The following is a list of additional operation and maintenance items to be implemented by the owner/governing group to maintain the features proposed in this project.

- A. Proper storage, use, and disposal of hazardous chemicals, including automobile fluids, pesticides, paints, solvents, etc. shall be required. Information should be provided on chemicals of concern, proper use, and disposal options. Recycling programs for used motor oil, antifreeze, and other products should be developed.
- B. Vehicle Washing. This management measure involves educating the owner on the water quality impacts of the outdoor washing of vehicles and how to avoid allowing polluted runoff to enter the storm drain system. Outdoor vehicle washing has the potential to result in high loads of nutrients, metals, and hydrocarbons which is conveyed by the detergent-rich water into storm drains.
- C. Recycling, spill prevention and response plans, and proper material storage and disposal of potentially hazardous materials shall be implemented. It will be the responsibility of the owner to contain and legally remove any materials that are spilled onsite. The use of dry floor cleaners and absorbent materials and limiting the use of water to clean pavement is encouraged. Care should be taken to avoid accidental disposal of hazardous materials.
- D. Provisions for storing trash and waste products shall be implemented. The waste materials shall be collected by the owner and all materials shall be properly disposed of.
- E. Requirements for routine inspections and maintenance of stormwater best management practices. Routine inspections shall be performed to ensure the correct functioning of stormwater best management practices. See the specific maintenance criteria for detail regarding inspections and maintenance frequency.
- F. Requirements for Storage and Use of Fertilizers, Herbicides, and Pesticides. Fertilizers, pesticides, herbicides, lawn care chemicals, or other leachable materials shall be used in accordance with the Lawn Care Regulations of the Massachusetts Pesticide Board, 33 CMR 10.03 (30,31), as amended, with manufacturer’s label instructions and all other necessary precautions to minimize adverse impacts on surface and groundwater. The storage of any such materials shall be within structure designed to prevent the escape of contaminated runoff or leachate.
- G. Provisions for prevention of illicit discharges to the stormwater management system shall be implemented. Any illicit discharges to the stormwater management system shall be prohibited. It will be the owner’s responsibility to ensure compliance with the legal disposal of all materials and containment/cleanup of any illicit discharges.
- H. Training for staff or personnel involved with implementation of the Long-Term Pollution Prevention Plan shall be required. The owner/governing group will be responsible for the implementation of the measures set forth in the Long-Term Pollution Prevention Plan. Documentation that personnel and owners involved with the implementation of the Long-Term Pollution Prevention Plan have been trained to conduct such tasks shall be documented.

## 4. Winter and Snow Conditions

---

The following is a list of additional operation and maintenance items to be implemented by the owner during winter and snow conditions.

- A. Snowfall shall be stored on the grassed areas surrounding the pavement areas, excluding any areas utilized for stormwater management practices. As needed, any snow that cannot be stored on site shall be trucked off site and disposed of properly.
- B. Winter road salt and/or sand use and storage restrictions shall be implemented based on any restrictions issued for the project. Sodium chloride for ice control shall be used at the minimum salt to sand ratio which is consistent with the Massachusetts Department of Environmental Protection's guidelines. Sodium chloride, calcium chloride, chemically treated abrasives or other chemicals used for the removal of ice and snow on roads/drives shall not be stored on site.

## 5. Public Safety Features

---

The proposed site design utilizes the following features which have been incorporated to ensure the safety of the public:

- A. Control and collection of stormwater runoff through positive drainage and curbing directing it towards the drainage inlets;
- B. Heavy-duty stormwater drain manhole covers and catch basin grates have been designed to withstand H<sub>2</sub>O loading;
- C. Reduction of peak discharge rates from the site in the post-development condition as compared to the pre-developed conditions;
- D. Development and implementation of an Operations & Maintenance Plan to ensure the stormwater management system continues to function as designed.

## 6. Estimated Cost of Maintenance

The following budget was prepared as an estimate of inspection and maintenance costs for the stormwater management system. The budget is an estimate only as the costs may vary depending on the level of sediment accumulation and frequency of maintenance tasks required.

BMP Inspections	Number of Occurrences	Maintenance Cost	Number of Structures	Sum
Water Quality Unit	2/year	\$100	2	\$400
Catch Basin	4/year	\$30	4	\$480
Isolator Row	2/year	\$100	1	\$200
Subsurface Infiltration Basin	2/year	\$100	1	\$200
Level Spreader	2/year	\$50	2	\$200
Total Estimated Annual Cost of Inspections				\$1,480







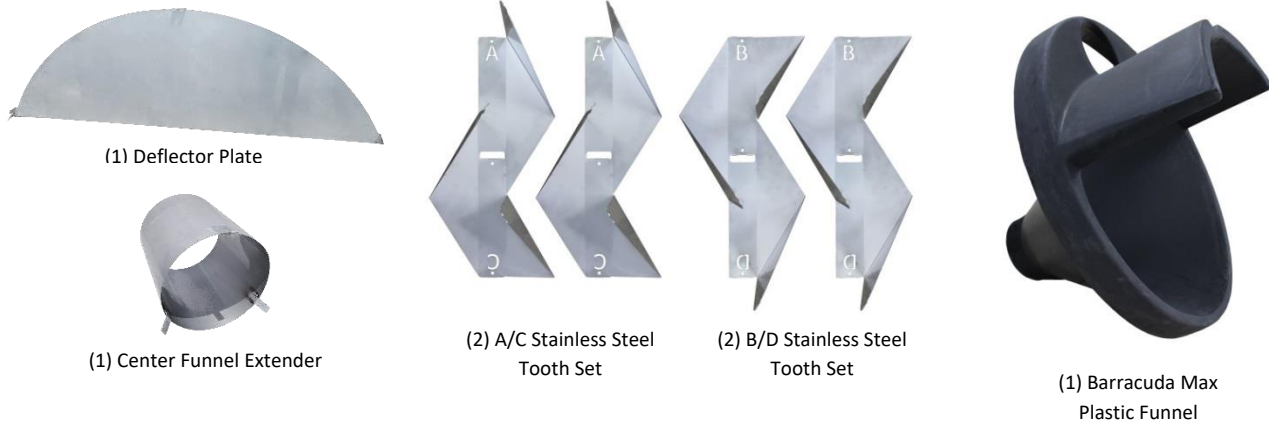

BMP Maintenance	Number of Occurrences	Maintenance Cost	Number of Structures	Sum
Water Quality Unit	2/year	\$500	2	\$2,000
Catch Basin	4/year	\$50	4	\$800
Isolator Row	2/year	\$100	1	\$200
Subsurface Infiltration Basin	2/year	\$500	1	\$1,000
Level Spreader	1/year	\$600	2	\$1,200
Total Estimated Annual Cost of Maintenance				\$5,200

# ADS® Barracuda® Concrete Installation Guide

## ADS Barracuda Max & Barracuda S4, S6, S8 Concrete Installation Guide

This installation guide is reference for installing the Barracuda Max S4, S6, S8 Water Quality Units into a precast concrete structure in the field.



S4	 (4) Stainless Steel Funnel Mounting Flanges	 (1) Roll of Conseal®	 (16) Concrete Anchor 1/4" x 2 1/4"
S6	 (4) Stainless Steel Funnel Mounting Flanges	 (3) Roll of Conseal®	 (16) Concrete Anchor 1/4" x 2 1/4"
S8	 (8) Stainless Steel Funnel Mounting Flanges	 (4) Roll of Conseal®	 (22) Concrete Anchor 1/4" x 2 1/4"

Please check that all components are on site. Below is a list of tools that may be required for installation.

- 1/4" Diameter Carbide Tipped Concrete Bit
- Standard Electrical or Battery Operated Drill
- Adjustable Wrench
- Marker for writing on the concrete wall
- Hammer Drill for Concrete (Fits the 1/4" Diameter Concrete Drill Bit)
- 7/16" Driver or deep socket for installation of provided 1/4" Concrete Wedge Anchors
- Hammer
- Level
- Ladder that will extend to bottom of the structure
- Safety Glasses
- Hard Hat
- Protective Gloves
- Site Drawings
- ADS Design Layout

## Installation Instructions (These directions assume the manhole base and riser have been assembled, but that the top slab/cone has not been set).

\*Do not insert the inlet or outlet pipes until after the Barracuda Max internals have been installed. If pipes must be inserted in advance, the pipes should not protrude into the structure as they will interfere with installation of the bowl.

1. Install mounting flanges for the Barracuda Max plastic funnel. These flanges need to be installed at the same height, as indicated by model in Table 1. For example, the anchor holes for S4 flanges should be drilled 77" (1925 mm) from the sump floor. S4 and S6 models have four flanges and they need to be evenly spaced at 12, 3, 6, and 9 o'clock positions. S8 funnels require eight flanges that also need to be evenly spaced (i.e., forty-five degrees on a circle) around the inside of the manhole. This flange points are typically located in the third manhole section from the sump and also contain the pipe openings for the Barracuda Max unit. Use the same anchor procedure as you will when mounting the teeth (see step #4 below), using the 1/4" (6.25 mm) concrete drill bit to drill 1 1/4" (31.25 mm) deep holes. Do not over drill the depth of the anchors. Lightly hammer the anchors in place and use locking nuts to firmly secure the flanges (Figure 1).
2. Next, mount the four sets of teeth vertically inside the manhole sump. Using the engineer's plans or the ADS layout, determine the correct orientation for the plastic funnel outlet hole in relation to the outlet pipe (Figures 2 and 5). The first set of teeth (marked as "A" on the teeth part) will be mounted under the center of the outlet hole from the Bowl. Mark that location with a plumb vertical line, this will serve as the "12 o'clock" landmark in the manhole (Figure 3). Repeat this process to mark lines at the 3, 6, and 9 o'clock positions for a total of four.
3. Each kit includes four sets of teeth. Two of these sets are stamped with the letters A and C. The other two sets are stamped B and D. The ADS shop drawing layout will label the teeth letters and all designs will be the A/B configuration (Figure 5). You will install each set of teeth in the correct location, with the indicated letter facing up (Figure 4). See Table 1 for the correct elevation for the top anchor location of each tooth set, measured from the sump floor for each Barracuda Max Unit. The teeth anchors are all at the same elevation. For example, for an S4 Barracuda the top anchor of an A or B indicated set of teeth will be 60" (1500 mm) off the sump floor. Mark the top anchor elevations on each of your four vertical lines (Figure 3), noting that A and B sets of teeth will be at the same height.



Figure 1



Figure 2



Figure 3

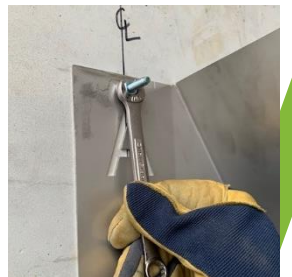
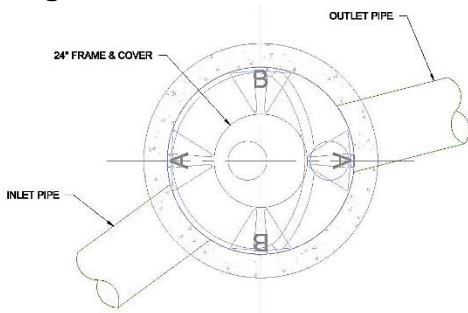

Figure 5

Figure 4



4. To fasten the sets of the teeth to the manhole, use the ¼" concrete drill bit and drill holes approximately 1¼" (31.25 mm) deep at your marked top anchor locations. Do not over drill into the concrete wall. Using a hammer, lightly tap the concrete anchors into the drilled holes (Figure 4). Hang the tooth set on the top anchor with the correct letter facing up and use a locking nut to loosely secure the tooth set to the wall (do not fully tighten the locking nut at this point). With the set of teeth hanging from the top anchor, line up and mark the bottom anchor location and drill the hole. Then hammer the bottom anchor in place and secure the teeth with a lock nut. Use an adjustable or socket wrench to tighten all the top and bottom locking nuts, except for the top nut on the outlet set of teeth (see step #5 below for the deflector plate installation, which will share the top anchor post), so that the teeth are firmly secured to the wall.
5. To attach the deflector plate to the concrete manhole you will use the exit tooth's top concrete anchor and share that linking point with the center tab of the deflector plate. Place the center tab of the deflector plate over the anchor bolt "post" on the outlet set of teeth and hand tighten the nut. Ideally, the plate will be held in place by this center point. Mark the location of the additional mounting tabs for the deflector plate while holding the plate relatively level. All deflector plate concrete anchors will be at the same elevation as the top tooth linking points and the anchors will be installed like the description in step #4. Once the two outer deflector plate linking points have been located, the installer can draw a vertical line and measure the exact location corresponding to the "high" teeth anchoring elevation. Once the deflector plate concrete anchors are installed tighten the nuts to complete the fastening of the deflector plate to the wall of the structure. See Figure 6 to show this more clearly.
6. Lower the plastic funnel into the structure (Figure 7), orienting the weir and outlet hole as depicted in the ADS layout (as identified in step 1). S6 and S8 units have eyebolts threaded holes on the top of the funnel to assist in lifting, and the eyebolts are provided in the equipment kit. If the eyebolts are misplaced, S6 units have ¾" (9 mm) -16 threads and S8 units utilize ½" (12 mm) -13 threads. After the bowl is in place, install the center funnel extender through the hole and seat it until the tabs of the extender touch the bowl itself (Figure 8). This is a friction-based attachment and no fasteners are needed.
7. Next, you'll use Conseal to fill any gaps around the funnel. S6 and S8 units are provided with a metal funnel plug. This plug is placed in the funnel opening for worker safety and must be utilized ANYTIME SOMEONE ENTERS THE STRUCTURE. Unroll the Conseal and wedge it between the funnel and manhole to create a seal (Figure 9). Conseal should also be used to seal between the vertical edges of the weir wall and the manhole. The plastic funnel can expand with high temperature. Install the funnel during cooler parts of the day, or keep the funnel shaded until installation can mitigate fitment issues. Once the Conseal is installed, the internal component installation is complete. The funnel plug may be discarded (if applicable), and the top slab can be set. If the application calls for a grated inlet, orient the slab so the grate is above the inlet (large bowl) side of the plastic funnel.

For maintenance details, please refer to the Barracuda Max Maintenance Manual. If the application requires a trash rack or oil boom, reference the appropriate supplementary installation instructions.



Figure 6



Figure 7



Figure 8

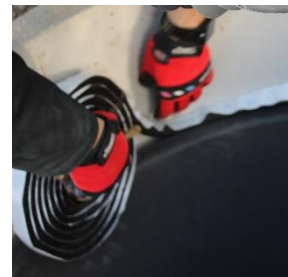

Figure 9

**Table 1**

	<b>S4</b>	<b>S6</b>	<b>S8</b>
Top Anchor Elevation from Sump Floor (A and B tooth indication)	60" (1270 mm)	68" (1475 mm)	90" (1880 mm)
Funnel Flange Anchor Elevation from Sump Floor	77" (1960 mm)	77" (1960 mm)	127" (3220 mm)

**Note:** Distances can be +/- 1-2 inches (25-50 mm) from these locations for the A, and B teeth, but flange elevations should be adhered to as much as possible and can only be lowered a maximum of 1 inch (25 mm) from these values listed above.

This guide is intended for field installations of Barracuda Max S4, S6, and S8 water quality units into precast manholes. For pre-casters installing internal components prior to job site delivery, contact ADS for possible modifications to component elevations.



# Barracuda<sup>®</sup> Max & Barracuda Maintenance Guide

One of Barracuda's advantages is the ease of maintenance. Like any system that collects pollutants, the Barracuda must be maintained for continued effectiveness. Maintenance is a simple procedure performed using a vacuum truck or similar equipment. The systems were designed to minimize the volume of water removed during routine maintenance, reducing disposal costs.

Contractors can access the pollutants stored in the manhole through the manhole cover. This allows them to gain vacuum hose access to the bottom of the manhole to remove sediment and trash. There is no confined space entry necessary for inspection or maintenance.

The entire maintenance procedure typically takes 2 to 4 hours, depending on the system's size, the captured material, and the vacuum truck's capacity.

Local regulations may apply to the maintenance procedure. Safe and legal disposal of pollutants is the responsibility of the maintenance contractor. Maintenance should be performed only by a qualified contractor.

## Inspection and Cleaning Cycle

Periodic inspection is needed to determine the need for and frequency of maintenance. You should begin inspecting as soon as construction is complete and then on an annual basis. Typically, the system needs to be cleaned every 1-3 years.

Excessive oils, fuels or sediments may reduce the maintenance cycle. Periodic inspection is important.

## Determining When to Clean

To determine the sediment depth, the maintenance contractor should lower a stadia rod into the manhole until it contacts the top of the captured sediment and mark that spot on the rod. Then push the probe through to the bottom of the sump and mark that spot to determine sediment depth.

Maintenance should occur when the sediment has reached the levels indicated in the Storage Capacity Chart.

## Barracuda Storage Capacities

Model	Manhole Diameter in. (mm)	Total System Volume Gallons (Liters)	Treatment Chamber Capacity Gallons (Liters)	Standard Sediment Capacity (20" depth) Yards <sup>3</sup> (meters <sup>3</sup> )	NJDEP Sediment Capacity (50% of standard depth) Yards <sup>3</sup> (meters <sup>3</sup> )
S3	36 (900)	264 (999)	212 (803)	0.44 (0.34)	0.22 (0.17)
S4	48 (1200)	665 (2517)	564 (2135)	0.78 (0.60)	0.39 (0.30)
S6	72 (1800)	1497 (5667)	1269 (4804)	1.75 (1.34)	0.88 (0.67)
S8	96 (2400)	4196 (15884)	3835 (14517)	3.10 (2.37)	1.55 (1.19)

## Maintenance Instructions

1. Remove the manhole cover to provide access to the pollutant storage. Pollutants are stored in the sump, below the bowl assembly visible from the surface. Access this area through the 8" (200 mm), 10" (250 mm), 15" (375 mm) or 20" (500 mm) diameter access cylinder.
2. Use a vacuum truck or other similar equipment to remove all water, debris, oils and sediment. See figure 1.
3. Use a high pressure hose to clean the manhole of all the remaining sediment and debris. Then, use the vacuum truck to remove the water.
4. Fill the cleaned manhole with water until the level reaches the invert of the outlet pipe.
5. Replace the manhole cover.
6. Dispose of the polluted water, oils, sediment and trash at an approved facility.
  - a. Local regulations prohibit the discharge of solid material into the sanitary system. Check with the local sewer authority for authority to discharge the liquid.
  - b. Some localities treat the pollutants as leachate. Check with local regulators about disposal requirements.
  - c. Additional local regulations may apply to the maintenance procedure.

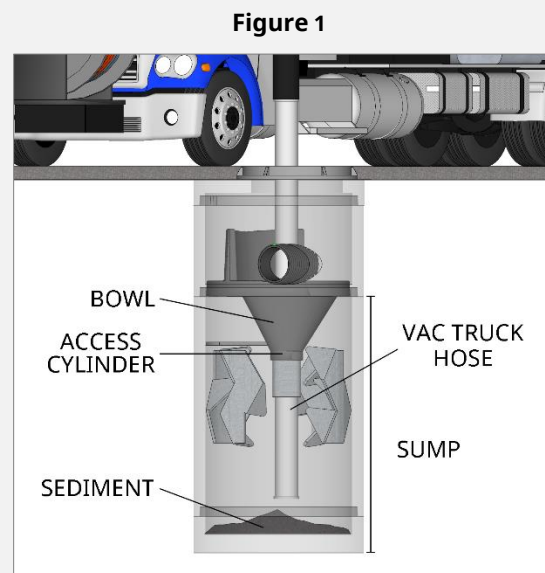

Project: \_\_\_\_\_

Responsible Party: \_\_\_\_\_

Address: \_\_\_\_\_

Date: \_\_\_\_\_

BPM Name: \_\_\_\_\_

Page: 1 of 1

### Operation & Maintenance Inspection Checklist

BMP Element:	Potential Problem:	Resolution:	Pass	Fail	Recommended Remediation
Deep-Sump Catch Basins	Sediment has accumulated to a depth greater than the original design depth for sediment storage, approximately 2-feet of sediment.	Remove the sediment and dispose of in accordance with local and state regulations.			
Stormwater Piping	Blockage of inlet/outlet pipes due to debris or sediment accumulation.	Remove any debris and sediment via proper means. Dispose of debris/sediment in accordance with local & state regulations			
Roof Leaders	Downspout connections have been damaged or disconnected.	Repair and reconnect downspout connections.			
	Roof leaders are surcharging at the downspout connections	Open and inspect at cleanout locations and remove any blockages.			
Proprietary Treatment Device	Sediment has accumulated to a depth greater than the original design depth for sediment storage.	Remove sediment and disposed of in accordance with local and state regulations.			
Subsurface Infiltration Basin	Accumulation of sediment at the inlet structure above maintenance level.	Remove the sediment and conduct proper maintenance to the up-gradient pretreatment devices.			
Isolator Row	Accumulation of sediment over 3-inches within the isolator row.	Remove the sediment and conduct the proper maintenance per the Isolator Row Operation and Maintenance Manual.			
Flared End Sections	Vegetation has started to grow within the riprap area.	Remove vegetation immediately.			
	Accumulation of sediment/debris at the culvert inlet.	Remove sediment or debris such that the culvert has free flow.			
	Erosion is occurring where riprap has been dislodged.	Remedy scoured area and replace riprap immediately.			
Level Spreader	Sediment has accumulated in riprap channel void space.	Remove the sediment and dispose of in accordance with local and state regulations and replace riprap.			
	Down-gradient gullies have formed due to sheet flow concentration.	Fill gullies with native backfill, No. 6 pea-stone, topsoil and erosion control blanket. Sod or re-seed with stabilized erosion control grass mix.			

Inspector's Signature \_\_\_\_\_

Date \_\_\_\_\_



## Appendix H: Illicit Discharge Compliance Statement



## Illicit Discharge Compliance Statement

---

The owners of the land/responsible party will be responsible for prohibiting illicit discharges to the stormwater management system during construction and during its life of operation. The stormwater management system is comprised of the components for conveying, treating, and infiltrating stormwater runoff on-site, including stormwater best management practices and any pipes intended to transport stormwater to the groundwater, a surface water, or municipal separate storm sewer system. An illicit discharge shall constitute any connection or discharge to the stormwater management system including, but not limited to, wastewater discharges, discharge of stormwater contaminated by contact with process wastes, raw materials, toxic pollutants, hazardous substances, oil, or grease.

### Responsible Party\*:

136 East Street, LLC  
c/o Mr. Gerald Coderre  
383 Newton Street  
South Hadley, Massachusetts 01075

\*The party listed shall be responsible for implementation and record keeping of the requirements listed in this operation and maintenance plan. Upon sale of property or any other transition of ownership, the responsible party shall be reinstated as the new owner or any other group created as determined by the owner.



\_\_\_\_\_  
Signature of Responsible Party Representative

11/13/25  
\_\_\_\_\_  
Date

\_\_\_\_\_  
Signature of Responsible Party Representative\*\*

\_\_\_\_\_  
Date

\*\*Required upon transfer of ownership



## Appendix I: Low Impact Development Considerations



# Low Impact Development Considerations

## “Deer Meadow Way”

### **Project Location:**

136 East Street  
South Hadley, Massachusetts 01075  
(Map 35, parcel 6)

### **Owner/Applicant:**

136 East Street, LLC  
c/o Mr. Gerald Coderre  
383 Newton Street  
South Hadley, Massachusetts 01075

RLA Project File: 250511

**September 30, 2025**

**R LEVESQUE ASSOCIATES, INC**

**A LAND PLANNING SERVICES COMPANY**

40 School Street · Westfield, MA 01085

p 413.568.0985 · f 413.568.0986 · [www.rlaland.com](http://www.rlaland.com)



## **Introduction**

Per the Massachusetts Stormwater Handbook, project proponents must consider environmentally sensitive site design and low impact development techniques to effectively manage stormwater. As a part of the proposed project, the proponent has considered a number of environmentally sensitive, low impact development techniques to prevent the generation of stormwater and non-point source pollution.

The following is a detailed description of the considerations for each low impact development measure. For ease of review, RLA has provided the consideration of each measure as detailed in the Massachusetts Stormwater Report Checklist.

## **Low Impact Development (Lid) Measures**

### **1. Environmentally Sensitive Project Approach**

The applicant is proposing to develop the locus property by constructing a condominium community and associated site improvements including a stormwater management system to mitigate the impacts of the proposed project. Site disturbance has been limited to the minimum areas required for site functionality.

### **2. No disturbance to any Wetland Resource Areas**

All proposed site improvements are located outside of existing wetland resource areas. Portions of the proposed site improvements are located inside wetland buffer zones. Disturbance to existing wetland buffer zones has been reduced to functional minimums required for applicant needs and town requirements.

### **3. Site Design Practices (e.g. clustered development, reduced frontage setbacks)**

This LID is not applicable for this project. The proposed project does not include any changes to existing property lines therefore no cluster or reduced frontage options are available.

### **4. Reduced Impervious Area (Redevelopment Only)**

The proposed project is not part of a redevelopment project. Impervious areas have been reduced to functional minimums required for applicant needs and town requirements.

### **5. Minimizing disturbance to existing trees and shrubs**

The proposed site improvements have been reduced to the minimums allowed by town requirements for the proposed project. Driveway widths and parking areas have been reduced to the minimum amounts required for functional accessibility based on town regulations. Demolition of existing trees and shrubs has been minimized to the extent practicable.

### **6. LID Site Design Credit Requested**

No LID Site Design Credit is requested for the proposed project.

**7. Use of "country drainage" versus curb and gutter conveyance and pipe**

Country drainage conveyance requires a larger footprint than curb and gutter conveyance and creates areas with undulating terrain. Due to pre-existing constraints and limitations of the project site, country drainage was not utilized on this project.

**8. Bioretention Cells (includes Rain Gardens)**

Due to stormwater burdens from the 100-year storm event, a subsurface infiltration basin was determined to be the only BMP capable of meeting required town regulations.

**9. Constructed Stormwater Wetlands (includes Gravel Wetlands designs)**

Constructed stormwater wetlands require very specific design scenarios such as large tributary areas to support wetland characteristics and high groundwater elevations among others. The sub-catchment drainage area for this project site is not large enough to incorporate a constructed stormwater wetland.

**10. Treebox Filter**

The extensive costs associated with treebox filters, along with the climatic conditions of the area over the winter, present unique circumstances that would only provide a maintenance problem and a potential hazard for the owner. Treebox filters were not selected as a favorable stormwater BMP for this project.

**11. Water Quality Swale**

Water quality swales are best management practices that require a greater footprint of development in order to facilitate the grading of the swale. Due to the limited available pervious areas within the project site, water quality swales were not utilized.

**12. Grass Channel**

Grassed channels were utilized along the northern and southern property lines to convey water to, a detention pond (northern property line), or directly to the design point (southern property line).

**13. Green Roof**

Based on project size and scope, green roofs were not selected as a cost-effective BMP for this project.

**14. Other**

Please see the Stormwater Report for more information.